

Introducing Rexa  
April, 17-23 Via Palermo, 14

Fuorisalone Milano 2023

# REXA FORWARD

REXA

# About Rexa

IT Azienda in continua evoluzione, attenta alle esigenze contemporanee e al mutare degli stili di vita, mantiene sempre saldo il legame con la propria storia e percorso progettuale fondato su ricerca stilistica, di materiali e funzionale.

EN Rexa is a company in continuous evolution, able to be attentive to contemporary needs and changing lifestyles, always maintaining a strong link with its history and design path based on stylistic, functional and material research.

# Exhibition

IT Rexa si presenta con le sue collezioni iconiche immerse in un'ambientazione sensoriale, raccontando la sua visione della stanza da bagno, fatta di materiali, funzionalità mimetiche ed ispirazioni lontane.

EN Rexa presents its iconic collections immersed in a more sensorial way, recounting its vision of the bathroom, made of materials, mimetic functionality and distant inspirations.

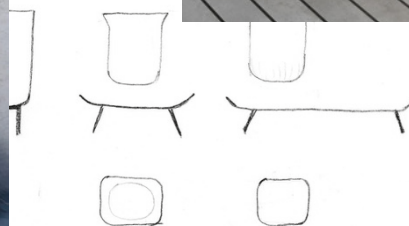

“Nell’allestimento abbiamo voluto affiancare alle collezioni Rexa degli accessori, prototipi, che parlano della curiosità verso tecniche artigiane e materiali antichi, abbinando in questa occasione la primitiva irregolarità del salice intrecciato a mano alla setosa precisione del Corian®.”

“In the installation we wanted to place alongside the Rexa collections accessories, prototypes, that speak of the curiosity for craft techniques and ancient materials, combining on this occasion the primitive irregularity of hand-woven willow with the silky precision of Corian®.”

Monica Graffeo



# Collections

IT Attraverso un intenso processo di sviluppo e di *redesign*, l'azienda ha selezionato alcune sue collezioni permanenti, caratterizzate da ampie possibilità espressive e di personalizzazione, e le ha arricchite di nuova linfa adattandole alle esigenze della vita contemporanea, con finiture attuali e funzioni aggiuntive.

EN Through a deep process of development and *redesign*, the company has selected some permanent collections, that include several expressive possibilities and customization, and has enhanced them with a new light, adapting them to the needs of a modern life, with new finishes and additional features.

Get more





IT Una conoscenza che si adatta  
agli spazi, calibrati e ottimizzati.  
EN Knowledge that adapts to any  
space, calibrated and optimized.

Di serie / Standard

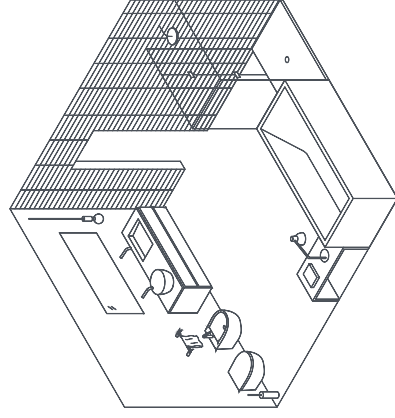

Su misura / Custom-made

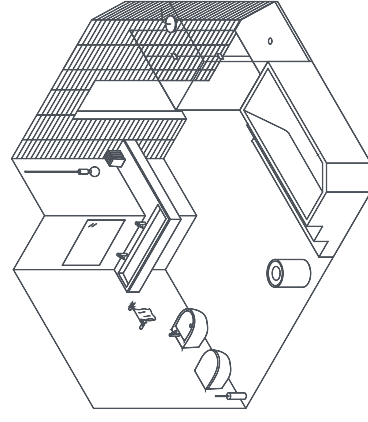

**This is Unico**

Introducing Rexa

Focus  
Corian® adapted to the project



IT Vision dà vita ad un programma di moduli sospesi e sommabili con vani e modalità di interazione progettati per rispondere alle esigenze quotidiane.

EN Vision introduces a program of suspended and summable modules with units and ways of interaction designed to meet everyday needs.

# This is Vision

design Monica Graffeo

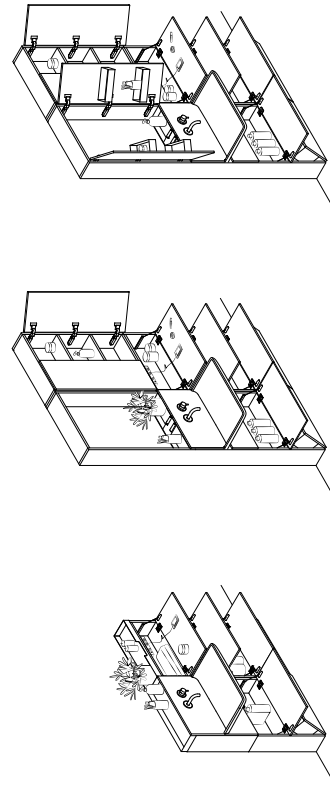

Focus  
Daily functionality



IT Moode genera soluzioni di progetto che spaziano tra diverse finiture, materiali e texture, consentendo abbinamenti versatili e personali.

EN Moode generates design solutions that range from different finishes, materials and textures, allowing versatile and personal combinations.

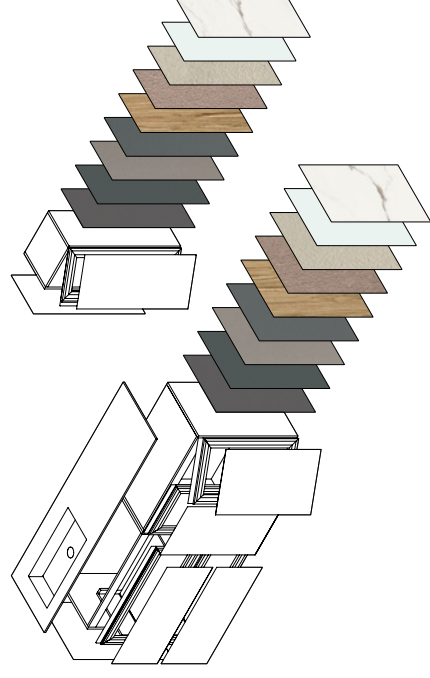

**This is Moode**

design Monica Graffeo

Focus  
Multi-material expression



IT Lo spirito della collezione è l'organizzazione: lavabi con organizer attrezzati e configurabili e accessori per gestire la routine quotidiana.

EN The soul of the collection is about organization: washbasins, configurable with organizers and accessories, to support the daily routine.

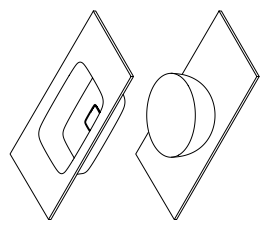
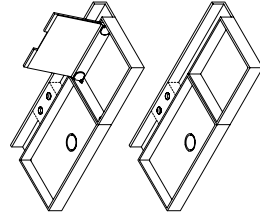
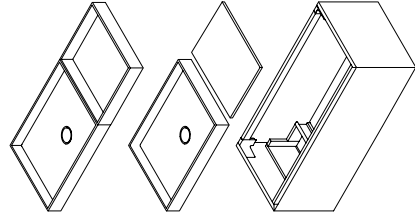

# This is Compact Living

design Monica Graffeo

Focus  
Enjoy the small spaces





IT Una collezione funzionale, all'insegna  
di contenimento e organizzazione.

EN A functional collection, dedicated  
to containment and organization.

**This is R1**

Introducing Rexa

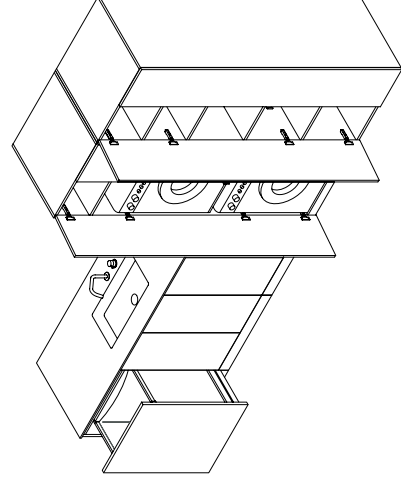

Focus  
Contemporary fittings



IT Elementi modulari sospesi, in appoggio su piano, panca o cavalletto per configurazioni armoniche e dinamiche.

EN Suspended modular elements, relying on top, bench or easle to create harmonic and dynamic configurations.

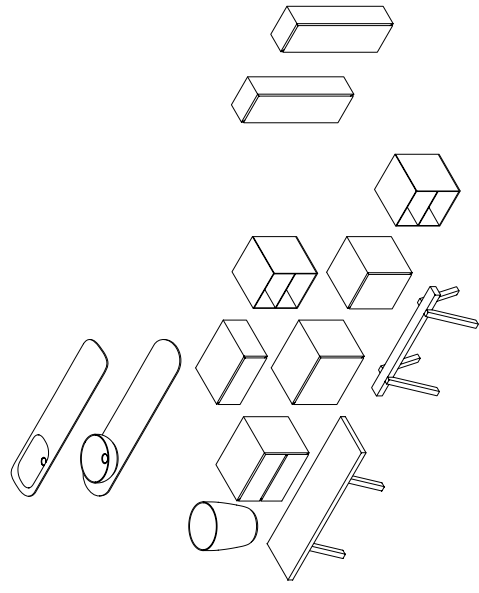

# This is Esperanto

design Monica Graffeo

Focus  
Compositional creativity



IT Il bagno è il luogo dove prendersi cura di sé lasciando in bella mostra gli oggetti come spazzole, sapone, sali... Si crea così un paesaggio vitale ed armonico.

EN In the bathroom you can take care of yourself and display freely all object like brushes, soaps, salts... creating a living and harmonic scenery.

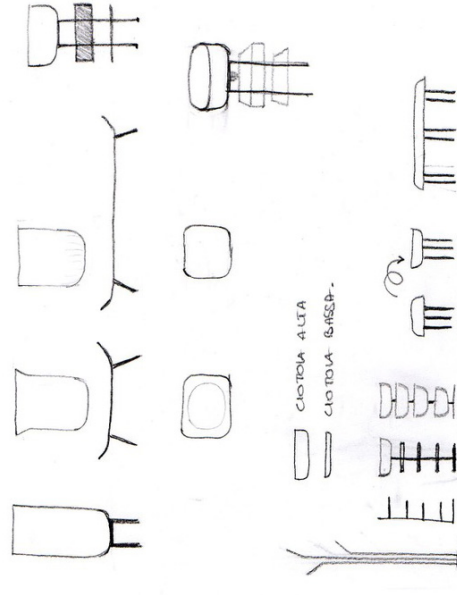

**This is Fonte**

design Monica Graffeo

Focus  
Welcoming functionality



IT Ritmo spaziale e armonia in  
composizioni d'impatto.  
EN Spatial rhythm and harmony  
in stunning compositions.

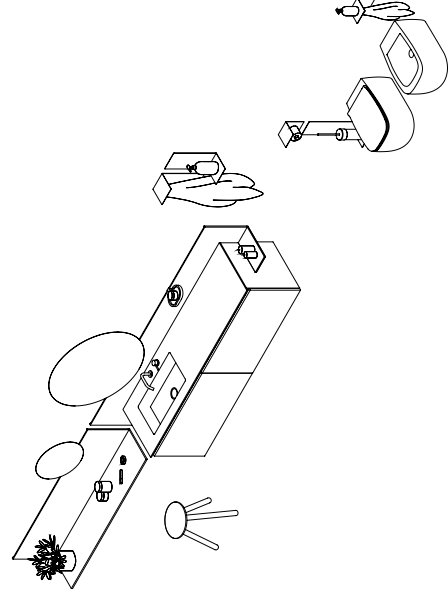

**This is Interlude**

design **Monica Graffeo**

Focus  
Material contrast

# Introducing Rexa

# Collections Index



Unico



R1



Vision



Esperanto



Moode

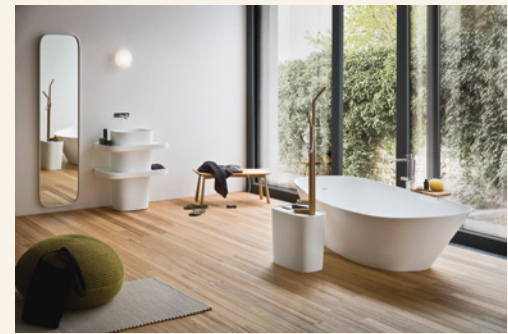

Fonte



Compact Living



Interlude

## Contatti

per informazioni e contatto  
for further information and contact

Rexa Design Srl  
Via Maniago 57/a  
33080 San Quirino (PN) - Italy  
+39 0434 593182  
info@rexadesign.it

Flagship Store Milano  
Via Molino delle Armi 14  
20123 Milano  
milano@rexadesign.it

scopri/discover more  
rexadesign.it



## Credits

Creative direction  
– Monica Graffeo

Brochure  
– Concept and design  
Chiara Torelli  
– Image production  
Studio Iride  
– Styling  
Stefano Gaggero  
– Photolithography  
Luce group

Printed in Italy by Grafiche Antiga  
03 2023

# REXA

©2023 Rexa Design Srl  
All rights reserved.

rexadesign.it

T +39 0434 593182

**REXA**

