

Luxury design

FLORIM

organizer/listino 2023



FLORIM È CERTIFICATA B CORP

FLORIM IS B CORP CERTIFIED

Guardiamo al business come una forza positiva in grado di generare profitto e allo stesso tempo creare un impatto virtuoso sulle persone e sull'ambiente. Da sempre.

Le nostre scelte, giorno dopo giorno, ci hanno portato a migliorare il nostro modo di fare impresa.

We conceive the business as a positive force able to generate profits and at the same time create a virtuous impact on people and the environment. Since forever.

Our choices, day after day, have led us to improve our way of doing business.

COSA SIGNIFICA ESSERE B CORP?

Ci siamo misurati con i **più alti standard di performance sociale e ambientale** e dopo un lungo e rigoroso processo di verifica **siamo diventati B Corp.**

Le aziende che riescono a ottenere questa certificazione sono le più evolute al mondo in termini di impatto positivo sia sociale che ambientale.

Costituiscono un movimento globale di 'Purpose Driven Businesses' che ha l'obiettivo di diffondere un nuovo **paradigma economico**, che vede le imprese come protagoniste nel **rigenerare la società**.



Certified



Corporation



Guarda il video *"Essere sostenibile è una scelta quotidiana"* con i volti di alcune delle "persone Florim" che ogni giorno contribuiscono a rendere l'azienda sempre più responsabile.

Watch the video "Being sustainable is a daily choice" with the faces of some of the "Florim people" who contribute to making the company even more responsible, every day.

WHAT DOES IT MEAN TO BE B CORP?

We vied with the **highest social and environmental performance standards**, and after a long and scrupulous verification process, **we became B Corp.**

Companies that succeed in obtaining this certification are the most evolved in the world in terms of their positive social and environmental impact.

They constitute a global movement of 'Purpose Driven Businesses' whose aim is to diffuse a **new economic paradigm**, whereby companies are the drivers of **social regeneration**.

**FOR
PROFIT**

Ricerca
il profitto
Seeks profit

Certified



Corporation

Ricerca il profitto e ha un impatto positivo sulle persone e l'ambiente
Seeks profit and has a positive impact on people and the environment

**NON
PROFIT**

Ha un impatto positivo sulle persone e l'ambiente
Has a positive impact on people and the environment

BUSINESS RIGENERATIVO

È in corso un **cambiamento culturale** epocale di cui siamo orgogliosi di essere parte. Uno dei principi fondamentali di tutte le B Corp è quello di adottare un business rigenerativo che si contrappone a quello estrattivo.

Rigenerare significa non solo diminuire l'impatto sulla natura e sull'ambiente che ci circonda, ma addirittura produrre effetti positivi, creando valore condiviso nella società e rigenerando la biosfera.

Diventano B Corp solo quelle aziende che misurano il loro impatto complessivo attraverso il Benefit Impact Assessment (BIA) superando il punteggio di 80 (in una scala da 0 a 200) ed entrando così in una élite di imprese **rigenerative**. Chi non supera questa soglia viene considerata **azienda estrattiva** ovvero per funzionare consuma risorse economiche, sociali e ambientali superiori di quanto sia in grado di generare come output.

REGENERATIVE BUSINESS

An historical **cultural shift** is under way, of which we are proud to be a part. One of the underlying principles of all B Corps is the adoption of a regenerative business model as opposed to an extractive one.

Regenerating means not only reducing the impact of business on our surrounding nature and environment, but also producing **positive effects, creating shared value in society and regenerating the biosphere**.

Only those companies that measure their overall impact through the Benefit Impact Assessment (BIA) exceeding the score of 80 points can be certified as B Corp, joining an elite of **regenerative** companies. Anyone who does not exceed this threshold is considered an **extractive company** or, in order to function, they consume higher economic, social and environmental resources than they are able to generate as output.

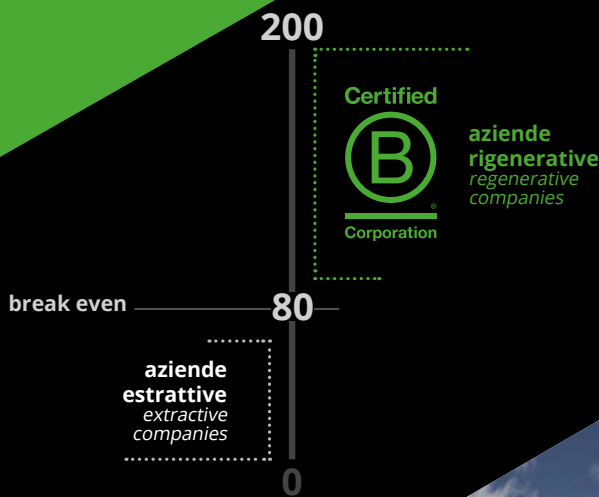

IL PUNTEGGIO DI FLORIM

Il punteggio conseguito da Florim Italia è di 98,1 punti e il consolidato, che comprende la consociata americana, è di 90,9 punti. Così Florim rientra tra le migliori B Corp al mondo.

Solo il 3% delle aziende riesce a superare l'iter di verifica imposto da **B Lab**, ente certificatore di origine americana che oggi opera a livello globale.

FLORIM'S SCORE

Florim Italia score is 98.1 points and the consolidated, which includes the American subsidiary, is 90.9 points. Florim is now one of the best B Corps throughout the world.

Only 3% of companies manage to pass the verification process implemented by **B Lab**, the US certifying body that currently operates on a global scale.

90.9

Florim consolidato
Florim consolidated

98.1

Florim Italia
Florim Italy

Azienda

Produciamo superfici ceramiche da oltre 60 anni con **passione, innovazione, impegno costante al miglioramento e responsabilità sociale** d'impresa. Sono queste le linee guida che contraddistinguono il nostro modo di fare impresa: il **MADE IN FLORIM**.

We produce porcelain stoneware surfaces with **passion, innovation and in a socially responsible way**. Those are the guidelines that identify our business and which can be summed up in a few words: **MADE IN FLORIM**.

Nous produisons des surfaces céramiques depuis plus de 60 ans avec **passion, innovation, recherche et une attention à la responsabilité sociale d'entreprise**. Ce sont les lignes phares qui guident notre mode de travailler: le **MADE IN FLORIM**.

Wir produzieren seit über 60 Jahren Keramikoberflächen mit **Leidenschaft, Innovationsgeist, ständigem Engagement für Verbesserungen und sozialer Unternehmensverantwortung**. Dies sind die Prinzipien, die unsere Arbeitsweise auszeichnen: kurz **MADE IN FLORIM**.

Producimos superficies cerámicas por más de 60 años con **pasión, innovación, compromiso de mejora constante y responsabilidad social**. Estos son los valores distintivos de nuestro modo de hacer empresa: el **MADE IN FLORIM**.



Luxury design

Materiali prestigiosi e ricercati delle materie più preziose che la natura propone. Lusso ostentato o sofisticato uso della materia per un'eleganza più informale e decisa. Rara, preziosa e intimamente legata al vivere dell'uomo, la materia viene reinterpretata nell'esprimere il concetto dell'ambiente moderno.

Prestigious and exquisite materials made of the most precious materials that nature has to offer. Ostentatious luxury or sophisticated use of materials for a more informal and bold elegance. Rare, luxurious and intimately linked to everyday life, the material is reinterpreted to convey the concept of a modern environment.

Des matériaux prestigieux et recherchés à partir des matières les plus précieuses offertes par la nature. Luxe ostentatoire ou utilisation sophistiquée de la matière pour une élégance plus informelle et audacieuse. Rare, précieuse et intimement liée à l'existence de l'homme, la matière est réinterprétée à travers l'expression du concept d'environnement moderne.

Kostbare, edle Materialien aus den wertvollsten Stoffen, die die Natur zu bieten hat. Betonter Luxus oder anspruchsvoller Einsatz des Materials für eine eher informelle und offensichtliche Eleganz. Das Material - selten, wertvoll und eng mit dem Leben des Menschen verbunden - wird neu interpretiert, um das Konzept des modernen Ambiente zum Ausdruck zu bringen.

Productos prestigiosos y refinados, de las materias más preciosas que la naturaleza ofrece. Lujo ostentado o sofisticada utilización de la materia, con el fin de obtener una elegancia más informal y decidida. Rara, preciosa e íntimamente ligada a la vida del hombre, la materia es reinterpretada para expresar el concepto del ambiente moderno.

elegance



preciousness



exclusivity



charm

Indice



gres porcellanato colorato in massa

coloured body porcelain stoneware / grès cérame colore dans la masse
durchgefärbte feinsteinzeug / gres porcelánico coloreado en masa

40/49	Étoile
72/87	I classici
122/131	Les bijoux
132/139	Les origines
162/171	Prexious
172/181	Rêves

vetro

glass / verre / glas / vidrio

50/55	Extra light
--------------	-------------

gres fine porcellanato

fine porcelain stoneware / grès cérame fin
feinsteinzeug-kollektionen / gres porcelánico fino

12/21	Ardoise
22/39	Atmosphères
62/71	Heritage luxe
72/87	I classici/Decowood
112/121	La roche
140/151	Matières
152/161	Planches
182/191	Selection oak

gres porcellanato decorato

decorated porcelain tiles
grès cérame décoré
verziertes feinsteinzeug
gres porcelánico decorado

56/61	Gold
88/111	I filati



La simbologia

SYMBOL/SYMBOLS/SYMBOL/SIMBOLOGIA

DIN 16165 ANNEX B: Scivolosità a piedi calzati: il materiale ceramico viene posto su un piano e oliato. Successivamente il piano viene progressivamente inclinato, mentre un operatore con scarpa di gomma cammina lungo il piano fino a quando non inizia a scivolare; la misura dell'angolo che si forma tra il piano inclinato e il suolo all'inizio dello scivolamento determina la classificazione del materiale. / Shod foot slipperiness: the ceramic material is placed on a surface and oiled. Subsequently, the surface is progressively tilted, while an operator with rubber shoes walks along the surface until he starts to slip; the measurement of the angle that is formed between the inclined surface and the ground when the slipping starts determines the classification of the material. / Glissance pieds chaussés : le matériau céramique est mis sur un plan et huilé. Le plan est ensuite incliné progressivement, tandis qu'un opérateur avec des chaussures en caoutchouc marche le long du plan jusqu'à ce qu'il ne commence à glisser ; la mesure de l'angle qui se forme entre le plan incliné et le sol au début du glissement donne la classification du matériau. / Rutsicherheit auf Schuhen: Das Keramikmaterial wird auf einer Fläche angebracht und mit einem Gleitmittel bestrichen. Daraufhin wird die Fläche nach und nach geneigt, während eine Prüfperson mit Gummischuhen die Fläche entlangläuft, bis sie ins Rutschen gerät. Die Größe des Winkels, der zwischen der geneigten Fläche und dem Boden zu Beginn der Rutschbewegung entsteht, bestimmt die Klassifizierung des Materials. / Deslizamiento con pies descalzos: el material cerámico se coloca sobre un plano y se aceita. Seguidamente el plano se inclina progresivamente, mientras que un operador con calzado de goma camina a lo largo del plano hasta que empieza a resbalar; la medida del ángulo que se forma entre la superficie inclinada y el suelo al principio del deslizamiento determina la clasificación del material.

DIN 16165 ANNEX A: Scivolosità a piedi nudi: il materiale ceramico viene posto su un piano e bagnato. Successivamente il piano viene progressivamente inclinato, mentre un operatore con piede nudo cammina lungo il piano fino a quando non inizia a scivolare; la misura dell'angolo che si forma tra il piano inclinato e il suolo all'inizio dello scivolamento determina la classificazione del materiale. / Barefoot slipperiness: the ceramic material is placed on a surface and made wet. Subsequently, the surface is progressively tilted, while an operator with bare feet walks along the surface until he starts to slip; the measurement of the angle that is formed between the inclined plane and the ground when slipping starts determines the classification of the material. / Glissance pieds nus : le matériau céramique est mis sur un plan et mouillé. Le plan est ensuite incliné progressivement, tandis qu'un opérateur pieds nus marche le long du plan jusqu'à ce qu'il ne commence à glisser ; la mesure de l'angle qui se forme entre le plan incliné et le sol au début du glissement donne la classification du matériau. / Rutsicherheit barfuß: Das Keramikmaterial wird auf einer Fläche angebracht und befeuchtet. Daraufhin wird die Fläche nach und nach geneigt, während eine Prüfperson barfuß die Fläche entlangläuft, bis sie ins Rutschen gerät. Die Größe des Winkels, der zwischen der geneigten Fläche und dem Boden zu Beginn der Rutschbewegung entsteht, bestimmt die Klassifizierung des Materials. / Deslizamiento con pies descalzos: el material cerámico se pone sobre un plano y se moja. Seguidamente el plano se inclina progresivamente, mientras que un operador con los pies descalzos camina a lo largo del plano hasta que empieza a resbalar; la medida del ángulo que se forma entre la superficie inclinada y el suelo al principio del deslizamiento determina la clasificación del material.

DCOF: Coefficiente di attrito dinamico: viene misurata la forza necessaria per mantenere in movimento un elemento (BOT 3000) rivestito in gomma dalla superficie della piastrella in condizioni di superficie bagnata; il rapporto tra la forza necessaria e il peso dell'elemento scivolante indica il Coefficiente di attrito dinamico. / Dynamic coefficient of friction: the force required to maintain the movement of an element (BOT 3000) coated with rubber on the surface of the tile in wet surface conditions is measured; the relationship between the force required and the weight of the slipping element indicates the dynamic coefficient of friction. / Coefficient de frottement dynamique : la force nécessaire pour maintenir en mouvement un élément (BOT 3000) revêtu en caoutchouc sur la surface du carreau en conditions de surface mouillée est mesurée ; la relation entre la force nécessaire et le poids de l'élément glissant indique le coefficient de frottement dynamique. / Dynamischer Reibungskoeffizient: Gemessen wird die Kraft, die erforderlich ist, um ein Element mit Gummiverkleidung (BOT 3000) durch die Fliese bei nasser Oberfläche in Bewegung zu halten. Das Verhältnis zwischen der erforderlichen Kraft und dem Gewicht des gleitenden Elements gibt den dynamischen Reibungskoeffizienten wieder. / Coeficiente de fricción cinética: se mide la fuerza necesaria para mantener en movimiento un elemento (BOT 3000) revestido de goma por la superficie de la baldosa bajo condiciones de superficie mojada; la relación entre la fuerza necesaria y el peso del elemento que resbala indica el Coeficiente de fricción dinámica.

SQUADRATO / SQUARED / EQUARRI / REKTIFIZIERT / ESCUADRADO

Piastrelle o lastre ceramiche portate a dimensioni predefinite, ognuno esattamente uguale all'altra (monocalibro) con sistema di mole abrasive. Ceramic tiles or slabs made to a pre-defined size, each one exactly the same as the others (single size), using a system of abrasive grinders. / Carreaux ou dalles céramiques mises aux dimensions prédéfinies, parfaitement identiques l'une à l'autre (mono-calibre) grâce à un système de disques abrasifs. / Fliesen oder Keramikplatten mit festgelegten Formaten. Alle Fliesen sind aufgrund der Verwendung des Schleifscheiben-Systems hundertprozentig identisch (Monokaliber). / Baldosas o piezas de cerámica que se realizan con dimensiones predefinidas, cada pieza es exactamente igual a la otra (mono dimensión) con sistema de discos abrasivos.

Grado di variazione cromatica

DEGREE OF COLOUR CHANGE/DEGRE DE VARIATION CHROMATIQUE/GRAD DER FARBABWEICHUNG/GRADO DE VARIACIÓN CROMÁTICA/

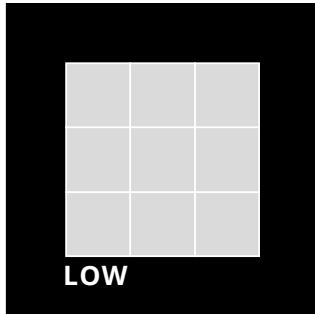

v1

PRODOTTO MONOCROMATICO.

The least amount of shade and texture variation.

Attainable in naturally fired clay products.

Produit monochromatique.

Eifarbiges produkt.

Producto monocromático.

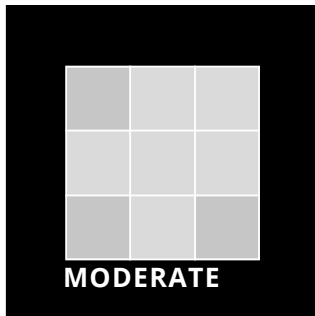

v2

PRODOTTO CON LEGGERA VARIAZIONE CROMATICA.

Light to moderate shade and texture variation within each carton.

Produit à légère variation chromatique.

Produkt mit leichter farbnuance.

Producto con una pequeña variación cromática.

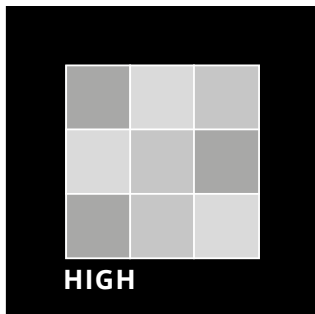

v3

PRODOTTO CON MARCATA VARIAZIONE CROMATICA.

High shade texture variation within each carton.

Produit à variation chromatique accentuée.

Produkt mit ausgeprägter farbnuance.

Producto con evidente variación cromática.

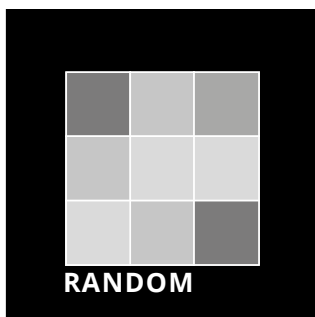

v4

PRODOTTO CON FORTE VARIAZIONE CROMATICA.

Very high shade and texture variation within each carton.

Produit à forte variation chromatique.

Produkt mit starker farbnuance.

Producto con fuerte variación cromática.

Superfici

SURFACES/SURFACES/OBERFLÄCHEN/SUPERFICIES

Naturale - Sablé / Matte / Mat / Matt / Mate

Superficie risultante dalla produzione di piastrella pressata senza lavorazioni successive alla cottura. / Surface coming from manufacturing pressed tiles without further work after firing. / Surface résultant de la production d'un carreau pressé sans être travaillé après la cuisson. / Die Oberfläche entsteht durch das Fliesenpressverfahren - im Anschluss an das Brennen erfolgt keine weitere Bearbeitung. / Superficie que resulta de la producción de baldosa prensada sin ulteriores elaboraciones después de la cocción.

Strutturato - Structuré / Structured / Structuré / Strukturiert / Estructurado

Superficie risultante dalla produzione di piastrella pressata, a tampone non liscio con intensità di evidenza variabile (da leggera ondulazione ad imitazione di pietra tagliata), senza lavorazioni successive alla cottura. / Surface coming from manufacturing pressed tiles, using a rough pad with variable intensity (from a slightly undulating one to inspired cut stone), without processing after firing. / Surface résultant de la production d'un carreau pressé, par un tampon à relief avec une intensité d'aspect variable (de légère ondulation à l'inspiration de la pierre taillée), sans être travaillé après la cuisson. / Die Oberfläche beruht auf dem Produktionsverfahren der Fliesenpressung unter Verwendung eines unglatten Stempels mit Intensitätsvariation (leichte Wellung entsprechend eines geschnittenen Steins). Es erfolgt keine Weiterbearbeitung nach dem Brennen. / Superficie que resulta de la producción de baldosa prensada, con tampón no liso con intensidad de evidencia variable (de ligera ondulación a imitación de piedra cortada), sin ulteriores elaboraciones después de la cocción.

Glossy - Shiny

Superficie ottenuta dopo la cottura sottoponendo le lastre a spazzolatura e lucidatura meccanica con serie di utensili abrasivi a grana decrescente. La superficie finale è morbida, lucida e riflettente. / Surface obtained after firing subjecting the slabs to mechanical brushing and polishing with a series of decreasing grain abrasive utensils. The final surface is soft, glossy and reflective. / Surface obtenue après cuisson, en soumettant les dalles à un brossage et un polissage mécanique avec un jeu d'outils abrasifs de grain décroissant. La surface finale est douce, brillante et réfléchissante. / Oberfläche, die nach dem Brand erhalten wurde, indem Platten mit einer Serie von Reibwerkzeugen mit kleiner werdender Struktur einer mechanischen Bürstung und Politur unterzogen wurde. Die fertige Oberfläche ist weich, glänzend und reflektierend. / Superficie obtenida después de la cocción sometiendo las losas a un procedimiento de cepillado y pulido mecánico con una serie de utensilios abrasivos de grano decreciente. La superficie final es suave, brillante y reflectante.

Superficie R+PTV / R+PTV Surface / Surface R+PTV / Oberfläche R+PTV / Superficie R+PTV

Superficie ottenuta dalla produzione di piastrella con tampone opportunamente sagomato così da raggiungere precise caratteristiche di sicurezza misurate secondo i principali metodi normativi in uso. La superficie finale è leggermente ruvida, opaca e conforme ai requisiti di scivolosità R10 (norma di riferimento DIN EN 16165 ANNEX B) e scivolosità Pendolo >36 wet (slider 96, norma di riferimento BS EN 16165 ANNEX C -AS/NZS 4586). Surface obtained from the production of tiles with appropriately shaped die in order to achieve precise safety characteristics measured based on the main prevailing regulatory methods in use. The final surface is slightly rough, matt and complies with R10 slipperiness requirements (reference standard DIN EN 16165 ANNEX B) and Pendulum slipperiness >36 wet (slider 96, reference standard BS EN 16165 ANNEX C -AS/NZS 4586). Surface obtenue à partir de la production de carreaux avec tampon opportunément façonné de manière à satisfaire des caractéristiques de sécurité précises, mesurées suivant les principales méthodes réglementaires en vigueur. La surface finale est légèrement rugueuse, mate et répond aux exigences de la classe de glissance R10 (norme de référence EN 16165 ANNEX B) et de glissance - test du pendule - humide - valeur >36 (slider 96, norme de référence BS EN 16165 ANNEX C -AS/NZS 4586). / Durch die Produktion von Fliesen mit entsprechend geformter Kachelunterlage erhaltene Oberfläche, um präzise Sicherheits-Charakteristiken zu erzielen, gemessen nach den wichtigsten angewandten Regelungsmethoden. Die fertige Oberfläche ist leicht angeraut, matt und konform mit den rutschhemmenden Eigenschaft R10 (Bezugsnorm EN 16165 ANNEX B) und der Rutschfestigkeit Pendolo >36 wet (slider 96, Bezugsnorm BS EN 16165 ANNEX C -AS/NZS 4586). / Superficie obtenida de la producción de baldosas con un molde específicamente fabricado para alcanzar características precisas de seguridad de conformidad con los principales métodos normativos vigentes. La superficie final es ligeramente áspera, opaca y conforme a los requisitos de resistencia al deslizamiento R10 (norma de referencia EN 16165 ANNEX B) y resistencia al deslizamiento Péndulo >36 mojado (slider 96, norma de referencia BS EN 16165 ANNEX C -AS/NZS 4586).

Soft

Superficie risultante dalla produzione di piastrella pressata, sottoposta a lavorazione meccanica di intensità intermedia, successiva alla cottura per dare alla superficie una finitura morbida e lievemente satinata, levigata ma non riflettente. / Surface coming from manufacturing pressed tiles, with a smooth or structured pad, subjected to intermediate intensity mechanical processing, with little removal of the material after firing to give the surface a smooth and slightly glazed finish, polished but not reflecting. / Surface résultant de la production d'un carreau pressé, par un tampon lisse ou structuré, soumis à un travail mécanique d'une intensité moyenne, avec une élimination minime de matière après la cuisson, afin de donner à la surface une finition douce et légèrement satinée, polie mais non réfléchissante. / Die Oberfläche entsteht durch eine Fliesenpressung unter Verwendung eines glatten oder strukturierten Stempels. Die Fliese wird einer mittelschweren mechanischen Bearbeitung unterzogen, wobei im Anschluss an das Brennen eine minimale Materialmenge abgetragen wurde. Dies verleiht der Oberfläche ein weiches, leicht satinierendes, geschliffenes aber reflektionsfreies Finish. / Superficie que resulta de la producción de baldosa prensada, con tampón liso o estructurado, sometido a un proceso mecánico de intensidad intermedia, con mínima eliminación de materia, posterior a la cocción para dar a la superficie un acabado suave y levemente satinado, pulido pero no reflectante.

Cannetè / Cannetè / Cannetè / Cannetè / Cannetè

Superficie risultante dalla produzione di piastrella pressata a tampone non liscio con rilievi geometrici regolari ad intensità crescente, senza lavorazioni successive alla cottura. / Surface resulting from the manufacturing of a tile pressed with a non-smooth pad featuring regular geometrical embossing with increasing intensity, with no further processing after firing. / Surface résultant de la production d'un carreau pressé par tampon non lisse, avec reliefs géométriques d'intensité croissante, sans usinage après la cuisson. / Die Oberflächen sind das Ergebnis des Produktionsverfahrens der Fliesenpressung unter Verwendung eines unglatten Stempels mit gleichmäßigen geometrischen Reliefs ohne eine Weiterbearbeitung nach dem Brennen. / Superficie resultante de la producción de azulejos prensados con tampones texturados, con relieves geométricos regulares de intensidad creciente, sin elaboraciones posteriores a la cocción.

Patiné - Adouci

Superficie ottenuta dopo la cottura sottoponendo a spazzolatura meccanica di intensità intermedia lastre non smaltate con tampone liscio o ondulato. La superficie finale è morbida, lievemente satinata, non riflettente. / Surface obtained after firing subjecting unglazed slabs to intermediate intensity mechanical brushing with smooth or wavy die. The final surface is soft, slightly satin-finished, non reflective. Surface obtenue après cuisson, en soumettant des dalles non émaillées à un brossage mécanique de moyenne intensité au moyen d'un tampon lisse ou ondulé. La surface finale est douce, légèrement satinée, non réfléchissante. / Oberfläche, die nach dem Brand erhalten wurde, indem nicht emailierte Platten mit glatter oder wellförmiger Kachelunterlage mit einer Serie von Reibwerkzeugen mit kleiner werdender Struktur einer mechanischen Bürstung mit mittlerer Stärke unterzogen wurden. Die fertige Oberfläche ist weich, leicht satiniert, nicht reflektierend. / Superficie obtenida después de la cocción sometiendo las losas no esmaltadas a un procedimiento de cepillado mecánico de intensidad intermedia con molde liso u ondulado. La superficie final es suave, ligeramente satinada, no reflectante.

Tabella Imballi

PACKAGE TABLE - TABLEAU DE EMBALLAGES - TABELLE FORMATE - TABLA DE LOS EMBALAJES

	scatola - box			pallet		
	pz	mq	kg	box	mq	kg

imballi per scatola
packages for boxes
emballages pour boîte
verpackungen für schachteln
embalajes para cajas

imballi per pallet
packages for pallets
emballages pour palette
verpackungen für paletts
embalajes para paletas

Tabella gruppi di prezzo

TABLE OF PRICE RANGES - TABLEAU GROUPE DES PRIX - TABELLE PREISGRUPPEN - TABLA DE GRUPO DE PRECIOS

Descrizione simboli / Description of symbols / Description symbols / Zeichenerklärung / Descripción de los símbolos			
■	▲	●	◆
PREZZO PER MATERIALE GESTITO A METRO QUADRO Price for materials managed per square metre. Prix pour matériau géré au mètre carré Materialpreis pro Quadratmeter Precio del material por metro cuadrado	*PREZZO PER MATERIALE GESTITO A PEZZO Price for materials managed per piece Prix pour matériau géré à la pièce Materialpreis pro Stück Precio del material por pieza	PREZZO PER MATERIALE GESTITO A NUMERO/COMPOSIZIONE Price for materials managed per number/composition Prix pour matériau géré à nombre/composition Materialpreis pro Anzahl/zusammenstellung Precio del material por número/composición	PREZZO PER MATERIALE GESTITO A METRO LINEARE Price for materials managed 1m Prix pour matériau géré à mètre linéaire Materialpreis pro Lfm Precio del material por ml
*costo al pezzo, vendita a scatola completa price per piece, sold by full boxes only • prix à la pièce, vente à la boîte complète • Stückpreis bei voller Kartonabnahme • precio à la pieza, venta à caja completada			



ARDOISE

gres fine porcellanato
fine porcelain stoneware
grès cérame fin
feinsteinzeug-kollektionen
gres porcelánico fino





ARDOISE

Una precisa dichiarazione estetica caratterizza la serie **Ardoise**: dare significato all'ambiente nascondendo il progetto, per essere percepita come semplice emozione. I colori e i diversi formati diventano elementi percettivi e comunicativi che aiutano a riscoprire il posto dell'anima, ad esaltare lo spessore e il valore di ogni architettura. La delicatezza cromatica porta alla mente un forte senso di libertà, aria, luce e spazi aperti, ricettivi alla creatività dell'abitare luoghi e culture in continuo mutamento. Lo spazio si adatta ai nostri desideri e Luxury design riesce a rendere contemporanea una materia senza tempo donandole una nuova vita.

The character of the **Ardoise** range is contained in a precise aesthetic statement: to give meaning to the environment by hiding the design, so that it is perceived simply in terms of the emotions. The colours and the various sizes are clear, communicative elements that help to rediscover an emotional dimension and enhance the importance and the value of any architecture. The delicate colours bring to mind a strong sense of freedom, air, light and open spaces, receptive to the creativity of living in places and cultures that are continually changing. The space adapts itself to our desires and Luxury design manages to make a timeless material modern, by giving it new life.

C'est une déclaration esthétique bien précise qui caractérise la série **Ardoise**: donner un sens à l'ambiance en cachant le projet, pour une perception de simple émotion. Les couleurs et les différents formats deviennent des éléments perceptifs et communicatifs, qui nous aident à redécouvrir notre âme, à exalter l'importance et la valeur de chaque architecture. La délicatesse chromatique offre à l'esprit une grande sensation de liberté, d'air, de lumière et de larges espaces, réceptifs à la créativité pour vivre des lieux et des cultures en constante évolution. L'espace s'adapte à nos désirs et Luxury design rend son actualité à une matière sans âge en lui offrant une nouvelle vie.

Eine präzise ästhetische Erklärung kennzeichnet **Ardoise**: der Umwelt Bedeutung schenken und das Projekt verbergen, damit es nur als einfache Emotion wahrgenommen wird. Die Farben und verschiedenen Formate werden zu Wahrnehmungs- und Kommunikationselementen, die uns dazu verhelfen, den Ort der Seele wieder zu entdecken und die Bedeutung und den Wert jeder Architektur hervorzuheben. Die chromatische Feinheit schenkt unserem Geist ein starkes Gefühl von Freiheit, Luft, Licht und Freiräume und macht uns empfängsbereit für die Kreativität des Wohnens an Orten und in Kulturen, die sich ständig verändern. Der Raum passt sich unseren Wünschen an und Luxury design gelingt es, eine zeitlose Materie modern zu gestalten und ihr ein neues Leben zu verleihen.

La serie **Ardoise** se caracteriza por una precisa declaración estética: dar significado al ambiente ocultando el proyecto, para ser concebida como una simple emoción. Los colores y los diferentes formatos se convierten en elementos perceptivos y comunicativos que ayudan a redescubrir el sitio del alma, a exaltar la dimensión y el valor de cada arquitectura. La delicadeza cromática hace recordar un fuerte sentido de libertad, aire, luz y espacios abiertos, que reciben la creatividad de habitar lugares y culturas que cambian continuamente. El espacio se adapta a nuestros deseos y Luxury design logra convertir en contemporánea una materia atemporal, revitalizándola.

ARDOISE

BLANC



IVOIRE



V3

R10
(matte)

R11
(grip)

CLASSE B
(grip)

DCOF>
0,42 Wet

9 mm 3/8" ↑↓



V3

R9
(matte)



DCOF>
0,42 Wet

6 mm 1/4" ↑↓

FLORIM OVERSIZE
magnUm

GRES FINE PORCELLANATO

FINE PORCELAIN STONEWARE/GRES CERAME FIN/FEINSTEINZEUG-KOLLEKTIONEN/GRES PORCELANICO FINO
SQUADRATO - SQUARED - EQUARRI - REKTIFIZIERT - ESCUADRADO*

9 mm 3/8" ↑↓		COLOR	SURFACE	20x80* 7 ^{7/8} "x31 ^{1/2} "	30,4x60,8 12"x23 ^{7/8} "	40x80* 15 ^{3/4} "x31 ^{1/2} "	60x120* 23 ^{3/8} "x47 ^{1/4} "	80x80* 31 ^{1/2} "x31 ^{1/2} "
ARDOISE		BLANC	MATTE	738885 ■ FL-09900	738705 ■ FL-06000	738717 ■ FL-07700	738711 ■ FL-09900	738644 ■ FL-09300
			GRIP	738785 ■ FL-09900	-	738723 ■ FL-07700	-	738650 ■ FL-09300
		IVOIRE	MATTE	738886 ■ FL-09900	738706 ■ FL-06000	738718 ■ FL-07700	738712 ■ FL-09900	738645 ■ FL-09300
			GRIP	738786 ■ FL-09900	-	738725 ■ FL-07700	-	738651 ■ FL-09300

6 mm 1/4" ↑↓		COLOR	SURFACE	120x240* 47 ^{1/4} "x94 ^{1/2} "	120x120* 47 ^{1/4} "x47 ^{1/4} "	60x120* 23 ^{3/8} "x47 ^{1/4} "
ARDOISE		BLANC	MATTE	745920 ■ FL-11300	745924 ■ FL-09700	757828 ■ FL-09100

ECRU



GRIS



V3

R10
(matte)

R11
(grip)

CLASSE B
(grip)

DCOF >
0,42 Wet

9 mm 3/8" ↑↓



V3

R9
(matte)

DCOF >
0,42 Wet

6 mm 1/4" ↑↓

FLOORM OVERSIZE
magnUm

GRES FINE PORCELLANATO

FINE PORCELAIN STONEWARE/GRES CERAME FIN/FEINSTEINZEUG-KOLLEKTIONEN/GRES PORCELANICO FINO
SQUADRATO - SQUARED - EQUARRI - REKTIFIZIERT - ESCUADRADO*

9 mm 3/8" ↑↓		COLOR	SURFACE	20x80* 7 ^{7/8"} x31 ^{1/2"}	30,4x60,8 12"x23 ^{7/8"}	40x80* 15 ^{3/4"} x31 ^{1/2"}	60x120* 23 ^{3/8"} x47 ^{1/4"}	80x80* 31 ^{1/2"} x31 ^{1/2"}
ARDOISE		ECRU	MATTE	738887 ■ FL-09900	738707 ■ FL-06000	738719 ■ FL-07700	738713 ■ FL-09900	738646 ■ FL-09300
			GRIP	738787 ■ FL-09900	-	738726 ■ FL-07700	-	738652 ■ FL-09300
		GRIS	MATTE	738888 ■ FL-09900	738708 ■ FL-06000	738720 ■ FL-07700	738714 ■ FL-09900	738647 ■ FL-09300
			GRIP	738788 ■ FL-09900	-	738727 ■ FL-07700	-	738653 ■ FL-09300

6 mm 1/4" ↑↓		COLOR	SURFACE	120x240* 47 ^{1/4"} x94 ^{1/2"}	120x120* 47 ^{1/4"} x47 ^{1/4"}	60x120* 23 ^{3/8"} x47 ^{1/4"}
ARDOISE		ECRU	MATTE	745921 ■ FL-11300	745925 ■ FL-09700	757829 ■ FL-09100
		GRIS	MATTE	745922 ■ FL-11300	745926 ■ FL-09700	757830 ■ FL-09100

ARDOISE

PLOMBE



NOIR



V3

R10
(matte)

R11
(grip)

CLASSE B
(grip)

DCOF>
0,42 Wet

9 mm 3/8" ↑↓



V3

R9
(matte)



DCOF>
0,42 Wet



6 mm 1/4" ↑↓

FLORIM OVERSIZE
magnUm





GRES FINE PORCELLANATO

FINE PORCELAIN STONEWARE/GRES CERAME FIN/FEINSTEINZEUG-KOLLEKTIONEN/GRES PORCELANICO FINO
SQUADRATO - SQUARED - EQUARRI - REKTIFIZIERT - ESCUADRADO*

9 mm 3/8" ↑↓		COLOR	SURFACE	20x80* 7 ^{7/8"} x31 ^{1/2"}	30,4x60,8 12"x23 ^{7/8"}	40x80* 15 ^{3/4"} x31 ^{1/2"}	60x120* 23 ^{3/8"} x47 ^{1/4"}	80x80* 31 ^{1/2"} x31 ^{1/2"}
ARDOISE		PLOMBE	MATTE	738889 ■ FL-09900	738709 ■ FL-06000	738721 ■ FL-07700	738715 ■ FL-09900	738648 ■ FL-09300
			GRIP	738789 ■ FL-09900	-	738728 ■ FL-07700	-	738654 ■ FL-09300
		NOIR	MATTE	738890 ■ FL-09900	738710 ■ FL-06000	738722 ■ FL-07700	738716 ■ FL-09900	738649 ■ FL-09300
			GRIP	738790 ■ FL-09900	-	738729 ■ FL-07700	-	738655 ■ FL-09300
6 mm 1/4" ↑↓		COLOR	SURFACE	120x240* 47 ^{1/4"} x94 ^{1/2"}	120x120* 47 ^{1/4"} x47 ^{1/4"}	60x120* 23 ^{3/8"} x47 ^{1/4"}		
ARDOISE		NOIR	MATTE	745923 ■ FL-11300	745927 ■ FL-09700	757831 ■ FL-09100		

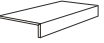
9 mm 3/8" ↑↓			30x30 11 ^{4/5"} x11 ^{4/5"}	21x40 8 ^{1/4"} x15 ^{3/4"}	30x30 11 ^{4/5"} x11 ^{4/5"}
	COLOR		 mosaico grip tessere 5x5	 modulo listello sfalsato	 modulo muretto 3D pz/box 6
ARDOISE	BLANC	739356 ■ FL-15600	739362 ■ FL-21000	739368 ▲ FL-03800	
	IVOIRE	739357 ■ FL-15600	739363 ■ FL-21000	739369 ▲ FL-03800	
	ECRU	739358 ■ FL-15600	739364 ■ FL-21000	739370 ▲ FL-03800	
	GRIS	739360 ■ FL-15600	739366 ■ FL-21000	739372 ▲ FL-03800	
	PLOMBE	739359 ■ FL-15600	739365 ■ FL-21000	739371 ▲ FL-03800	
	NOIR	739361 ■ FL-15600	739367 ■ FL-21000	739373 ▲ FL-03800	

PEZZI SPECIALI/SPECIAL TRIMS/PIÈCES SPÉCIALES/FORMSTÜCKE/PIEZAS ESPECIALES







9 mm 3/8" ↑↓			4,6x60 1 ^{4/5"} x23 ^{5/8"}	15x30x4 6"x11 ^{4/5"} x1 ^{4/7"}	33x120x3 13"x47 ^{1/4"} x1 ^{1/8"}	33x120x3 13"x47 ^{1/4"} x1 ^{1/8"}	33x120x3 13"x47 ^{1/4"} x1 ^{1/8"}	33x120x3 13"x47 ^{1/4"} x1 ^{1/8"}
	COLOR		 battiscopa	 elemento elle grip pz/box 6	 gradino pz/box 2	 angolo gradino dx pz/box 2	 angolo gradino sx pz/box 2	 angolo gradino dx/sx pz/box 1
ARDOISE	BLANC	745427 ◆ FL-01600	739350 ▲ FL-02000	739319 ▲ FL-20400	739325 ▲ FL-31100	739331 ▲ FL-31100	739337 ▲ FL-42900	
	IVOIRE	745430 ◆ FL-01600	739351 ▲ FL-02000	739320 ▲ FL-20400	739326 ▲ FL-31100	739332 ▲ FL-31100	739338 ▲ FL-42900	
	ECRU	745428 ◆ FL-01600	739352 ▲ FL-02000	739321 ▲ FL-20400	739327 ▲ FL-31100	739333 ▲ FL-31100	739339 ▲ FL-42900	
	GRIS	745429 ◆ FL-01600	739354 ▲ FL-02000	739323 ▲ FL-20400	739329 ▲ FL-31100	739335 ▲ FL-31100	739341 ▲ FL-42900	
	PLOMBE	745432 ◆ FL-01600	739353 ▲ FL-02000	739322 ▲ FL-20400	739328 ▲ FL-31100	739334 ▲ FL-31100	739340 ▲ FL-42900	
	NOIR	745431 ◆ FL-01600	739355 ▲ FL-02000	739324 ▲ FL-20400	739330 ▲ FL-31100	739336 ▲ FL-31100	739342 ▲ FL-42900	

ARDOISE	scatola - box			pallet		
	pz	m ²	kg	box	m ²	kg
20x80	6	0,96	21,41	48	46,08	1060
30,4x60,8	6	1,11	21,42	40	44,40	890
40x80	3	0,96	18,53	56	53,76	1070
60x120	2	1,44	28,08	30	43,20	870
80x80	2	1,28	24,96	40	51,20	1030
21x40 mod. list. sfal.	5	0,42	9,83	40	16,80	420
30x30 mosaico grip	11	1,00	23,40	30	30,00	730



ARDOISE	scatola - box			pallet		
	pz	ml	kg	box	m ²	kg
4,6x60 battiscopa	14	8,40	8,40	-	-	-

ARDOISE

6 mm 1/4"				30x30 11 ^{4/5"} x11 ^{4/5"}	30x30 11 ^{4/5"} x11 ^{4/5"}	30x30 11 ^{4/5"} x11 ^{4/5"}
	COLOR	SURFACE	 mosaico tessere 7,5x7,5 pz/box 11	 muretto tessere 7,5x15 pz/box 11	 mosaico tessere 1,5x3 pz/box 11	
	BLANC	MATTE	747759 ▲ FL-01800	747789 ▲ FL-01800	747812 ▲ FL-02700	
	ECRU	MATTE	747760 ▲ FL-01800	747790 ▲ FL-01800	747813 ▲ FL-02700	
ARDOISE 	GRIS	MATTE	747761 ▲ FL-01800	747791 ▲ FL-01800	747814 ▲ FL-02700	
	NOIR	MATTE	747762 ▲ FL-01800	747792 ▲ FL-01800	747815 ▲ FL-02700	

Nelle operazioni di posa a listoni sfalsati, si raccomanda sempre di fare in modo che il lato maggiore della piastrella termini a circa un terzo della lunghezza di quelle accanto (posa sfalsata "a 1/3"). - When installing staggered strips, we recommend that the tile's longer side should always end at about one-third of the length of the tiles next to it ("1/3" staggered installation) - Lors de la pose des listels décalés, il faut toujours faire en sorte que le côté le plus grand du carreau se trouve à environ 1/3 de la longueur des carreaux d'à côté (pose décalée "à 1/3"). - Beim Verlegen der Leisten in versetzter Form ist zu beachten, dass die höhere Seite der Fliese immer circa bei einem Drittels der Länge der sich daneben befindlichen Fliesen abschließt ("Um 1/3" versetzte Verlegung) - En las operaciones de colocación de listones escalonados, se recomienda hacerlo siempre de forma tal que el lado mayor del azulejo termine teniendo alrededor de un tercio de la longitud de los contiguos (colocación escalonada "a 1/3").

Per un effetto ottimale della posa, florim suggerisce di mantenere 2 mm di fuga per pose monoformato e 3 mm per combinare formati misti - For optimal installation results, florim recommends maintaining a joint of 2 mm 1/12" for single format installations and 3 mm 1/8" to combine mixed formats. - Pour réaliser une pose parfaite, florim suggère de maintenir 2 mm de joint pour la pose des monoformats, et 3 mm pour les combinaisons de formats mixtes. - Um einen optimalen effekt beim verlegen zu erzielen empfiehlt florim eine 2 mm fugе bei einformatigen verlegungen und 3 mm fugе bei formatkombinationen Para lograr los máximos resultados en la posa del producto, florim aconseja 2 mm de junta en aplicaciones monoformato y 3 mm en combinaciones de formatos mixtos.

In relazione alle differenti tecnologie produttive l'accostamento di prodotti con spessori diversi potrebbe presentare delle disomogeneità, se ne sconsiglia pertanto l'abbinamento. / Due to the different production technologies, contiguous installation of products with different thickness may give a non-homogeneous result. For this reason we do not recommend this option. / Vu que différentes technologies de production sont utilisées avec des épaisseurs différentes, des problèmes d'homogénéité pourraient se présenter, il est donc déconseillé de les poser ensemble. / Wegen unterschiedlicher Produktionstechnologien können die Fliesen mit verschiedenen Materialstärken optische Differenzen aufweisen. Von einem direkten Aneinanderlegen wird deshalb abgeraten. / Dadas las diferentes tecnologías productivas, la combinación de productos de diferentes espesores podría dar lugar a heterogeneidad, por lo que se desaconseja mezclarlas.

FLORIM OVERSIZE
magnUm

120x240/120x120/60x120

Specifica Imballo pag.
Packaging specifications on page
Spécifications d'emballage à page
Verpackungsdetail Seite
Especificaciones de embalaje a la página
204/205

Luxury design





ATMOSPHERES

gres fine porcellanato
fine porcelain stoneware
grès cérame fin
feinsteinzeug-kollektionen
gres porcelánico fino





ATMOSPHERÈS

Atmosphères è una collezione dal gusto ruvido ed elegante che reinterpreta in stile contemporaneo il lusso semplice ed informale della Pierre Bleue, una pietra sedimentaria originaria del Belgio che porta con sé un'energia profonda e coinvolgente. La sua particolare superficie, delicatamente eterogenea, e le tenui sfumature di colore raccontano una storia millenaria che risale ad un passato molto lontano, quando il territorio dell'odierno Belgio era bagnato da un mare ricco di formazioni coralline. Piccoli organismi e residui marini fossilizzati, come le conchiglie o i meravigliosi gigli di mare, si incorporano spontaneamente all'interno di queste rocce, creando un effetto estetico variegato e dal sapore antico.

Atmosphères is a collection with rough yet elegant taste offering a contemporary reinterpretation of the simple, informal luxury of Pierre Bleue, a sedimentary stone from Belgium with a profound, thrilling energy all its own. Its distinctive, delicately variegated surface and subtly graduated shades tell a story reaching back over the millennia to a very distant past, when the area that is now Belgium lay under a sea rich in coralline formations. Small creatures and fossilised marine residues, such as shells or the wonderful sea daffodil, were naturally incorporated in these rocks, creating a constantly changing aesthetic with an antique air.

Atmosphères est une collection au caractère brut et élégant qui réinterprète dans un style contemporain le luxe simple et informel de la Pierre Bleue, une pierre sédimentaire originaire de Belgique d'où émane une énergie profonde et captivante. Sa surface particulière, délicatement hétérogène, et ses subtiles nuances de couleurs racontent une histoire millénaire remontant à un passé très lointain, lorsque le territoire de l'actuelle Belgique était baigné par une mer riche en formations coralliennes. De petits organismes et résidus marins fossilisés, comme les coquillages ou les splendides Lis maritimes, s'amalgament Atmosphères de Rex est une collection au caractère brut et élégant qui réinterprète dans un style contemporain le luxe simple et informel de la Pierre Bleue, une pierre sédimentaire originaire de Belgique d'où émane une énergie profonde et captivante.

Die Kollektion **Atmosphères** besticht mit einer spröden Schönheit, die von der schlichten, luxuriösen Optik des Pierre Bleue inspiriert ist. Das in Belgien vorkommende Sedimentgestein ist auch unter dem Namen Blauwe Hardsteen oder Blaustein bekannt und zeichnet sich durch eine intensive, prägnante Ausstrahlung aus. In seiner dezent strukturierten Oberfläche und seinen zarten Farbschattierungen klingt eine tausendjährige Geschichte, eine ferne Vergangenheit an, als ein korallenreiches Meer das heutige Gebiet von Belgien überzog. Fossile Kleinlebewesen und Meeresbewohner wie Muscheln und Seelilien, die unregelmäßig im Gestein vorkommen, sorgen für eine abwechslungsreiche, geschichtsträchtige Oberfläche.

Atmosphères es una colección de sabor rústico y elegante que reinterpreta con estilo contemporáneo el lujo simple e informal de la Pierre Bleue, una piedra sedimentaria original de Bélgica que encierra una energía profunda y envolvente. Su superficie distintiva, delicadamente heterogénea, y los tenues matices de color narran una historia milenaria que se remonta a un tiempo remoto, cuando la zona ocupada actualmente por Bélgica estaba cubierta por un mar rico en formaciones coralinas. Pequeños organismos y restos marinos fosilizados, tales como las conchas y los maravillosos lirios de mar, se integran espontáneamente en estas piedras y crean un efecto estético variado y de gusto antiguo.

ATMOSPHÈRES

LUMIÈRE - ADOUCI



OMBRE - ADOUCI

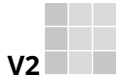

V2



R9

DCOF >
0,42 Wet

6 mm 1/4" ↑↓

FLORIM OVERSIZE
magnUm

GRES FINE PORCELLANATO
FINE PORCELAIN STONEWARE/GRES CERAME FIN/FEINSTEINZEUG-KOLLEKTIONEN/GRES PORCELANICO FINO
SQUADRATO - SQUARED - EQUARRI - REKTIFIZIERT - ESCUADRADO

6 mm 1/4" ↑↓		COLOR	SURFACE	120x280 47 ^{1/4"} x110 ^{1/4"}	120x240 47 ^{1/4"} x94 ^{1/2"}	120x120 47 ^{1/4"} x47 ^{1/4"}	60x120 23 ^{5/8"} x47 ^{1/4"}
ATMOSPHÈRES		LUMIÈRE	ADOUCI	773417 ■ FL-12400	773422 ■ FL-11300	773425 ■ FL-09700	773427 ■ FL-09100
		OMBRE	ADOUCI	773409 ■ FL-12400	773414 ■ FL-11300	773415 ■ FL-09700	773416 ■ FL-09100



LUMIÈRE - CANNETÉ

OMBRE - CANNETÉ



9 mm 3/8" ↑↓

GRES FINE PORCELLANATO
 FINE PORCELAIN STONEWARE/GRES CERAME FIN/FEINSTEINZEUG-KOLLEKTIONEN/GRES PORCELANICO FINO
 SQUADRATO - SQUARED - EQUARRI - REKTIFIZIERT - ESCUADRADO

9 mm 3/8" ↑↓	COLOR	SURFACE	60x120 23 ^{5/8"} x47 ^{1/4"}
	LUMIÈRE	CANNETÉ	773392 ■ FL-10300
ATMOSPÈRES			
	OMBRE	CANNETÉ	773393 ■ FL-10300

La superficie CANNETÈ è da utilizzare solo a rivestimento. / The CANNETE' surface is to be used as coating only. / La surface CANNETE' est à utiliser uniquement comme revêtement.
 Die glänzende CANNETE' ist nur als Wandfliesen zu verwenden. / La superficie CANNETE' se debe usar sólo con revestimiento.

ATMOSPHÈRES

HARMONIE - SABLÉ



HARMONIE - PATINÉ



V3
R10
(sablé)

R11
(structuré)

CLASSE B
(sablé)
(structuré)

DCOF>
0,42 Wet
(sablé)
(patiné)
(structuré)

BS EN 16165
ANNEX C
>36 wet
slider 4S
(structuré)

9 mm 3/8" ↑↓

GRES FINE PORCELLANATO

FINE PORCELAIN STONEWARE/GRES CERAME FIN/FEINSTEINZEUG-KOLLEKTIONEN/GRES PORCELANICO FINO

SQUADRATO - SQUARED - EQUARRI - REKTIFIZIERT - ESCUADRADO

9 mm 3/8" ↑↓	COLOR	SURFACE	60x120 23 ^{5/8"} x47 ^{1/4"}	80x80 31 ^{1/2"} x31 ^{1/2"}	40x80 15 ^{3/4"} x31 ^{1/2"}	60x60 23 ^{5/8"} x23 ^{5/8"}	30x60 11 ^{4/8"} x23 ^{5/8"}
		SABLÉ (NATURALE)	773341 ■ FL-09600	773377 ■ FL-09300	773382 ■ FL-06900	773356 ■ FL-06900	773362 ■ FL-05900
ATMOSPHÈRES	 HARMONIE	PATINÉ (SMOOTH)	773336 ■ FL-09900	773367 ■ FL-09600	773372 ■ FL-07300	773346 ■ FL-07300	773351 ■ FL-06200
		STRUCTURÉ (STUTTURATO)	773387 ■ FL-09600	-	-	-	-

AUORE - SABLÉ



AUORE - PATINÉ

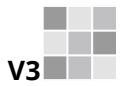

R10
(sablé)

R11
(structuré)

CLASSE B
(sablé)
(structuré)

DCOF>
0,42 Wet
(sablé)
(patiné)
(structuré)

BS EN 16165
ANNEX C
>36 wet
slider 4S
(structuré)

9 mm 3/8" ↑↓

GRES FINE PORCELLANATO

FINE PORCELAIN STONEWARE/GRES CERAME FIN/FEINSTEINZEUG-KOLLEKTIONEN/GRES PORCELANICO FINO
SQUADRATO - SQUARED - EQUARRI - REKTIFIZIERT - ESCUADRADO

9 mm 3/8" ↑↓	COLOR	SURFACE	60x120 23 ^{5/8"} x47 ^{1/4"}	80x80 31 ^{1/2"} x31 ^{1/2"}	40x80 15 ^{3/4"} x31 ^{1/2"}	60x60 23 ^{5/8"} x23 ^{5/8"}	30x60 11 ^{4/8"} x23 ^{5/8"}
		SABLÉ (NATURALE)	773342 ■ FL-09600	773378 ■ FL-09300	773383 ■ FL-06900	773357 ■ FL-06900	773363 ■ FL-05900
ATMOSPÈRES	 AUORE	PATINÉ (SMOOTH)	773337 ■ FL-09900	773368 ■ FL-09600	773373 ■ FL-07300	773347 ■ FL-07300	773352 ■ FL-06200
		STRUCTURÉ (STUTTURATO)	773388 ■ FL-09600	-	-	-	-

ATMOSPHÈRES

DÉSIR - SABLÉ



DÉSIR - PATINÉ



V3

R10
(sablé)

R11
(structuré)

CLASSE B
(sablé)
(structuré)

DCOF>
0,42 Wet
(sablé)
(patiné)
(structuré)

BS EN 16165
ANNEX C
>36 wet
slider 4S
(structuré)

9 mm 3/8" ↑↓

GRES FINE PORCELLANATO
FINE PORCELAIN STONEWARE/GRES CERAME FIN/FEINSTEINZEUG-KOLLEKTIONEN/GRES PORCELANICO FINO
SQUADRATO - SQUARED - EQUARRI - REKTIFIZIERT - ESCUADRADO

9 mm 3/8" ↑↓	COLOR	SURFACE	60x120 23 ^{5/8"} x47 ^{1/4"}	80x80 31 ^{1/2"} x31 ^{1/2"}	40x80 15 ^{3/4"} x31 ^{1/2"}	60x60 23 ^{5/8"} x23 ^{5/8"}	30x60 11 ^{4/8"} x23 ^{5/8"}
		SABLÉ (NATURALE)	773344 ■ FL-09600	773380 ■ FL-09300	773385 ■ FL-06900	773359 ■ FL-06900	773365 ■ FL-05900
ATMOSPHÈRES	DÉSIR	PATINÉ (SMOOTH)	773339 ■ FL-09900	773370 ■ FL-09600	773375 ■ FL-07300	773349 ■ FL-07300	773354 ■ FL-06200
		STRUCTURÉ (STUTTURATO)	773390 ■ FL-09600	-	-	-	-

CHARME - SABLÉ



CHARME - PATINÉ



V3

R10
(sablé)

R11
(structuré)

CLASSE B
(sablé)
(structuré)

DCOF>
0,42 Wet
(sablé)
(patiné)
(structuré)

BS EN 16165
ANNEX C
>36 wet
slider 4S
(structuré)

9 mm 3/8" ↑↓

GRES FINE PORCELLANATO

FINE PORCELAIN STONEWARE/GRES CERAME FIN/FEINSTEINZEUG-KOLLEKTIONEN/GRES PORCELANICO FINO
SQUADRATO - SQUARED - EQUARRI - REKTIFIZIERT - ESCUADRADO

9 mm 3/8" ↑↓	COLOR	SURFACE	60x120 23 ^{5/8"} x47 ^{1/4"}	80x80 31 ^{1/2"} x31 ^{1/2"}	40x80 15 ^{3/4"} x31 ^{1/2"}	60x60 23 ^{5/8"} x23 ^{5/8"}	30x60 11 ^{4/8"} x23 ^{5/8"}
		SABLÉ (NATURALE)	773343 ■ FL-09600	773379 ■ FL-09300	773384 ■ FL-06900	773358 ■ FL-06900	773364 ■ FL-05900
ATMOSPÈRES	 CHARME	PATINÉ (SMOOTH)	773338 ■ FL-09900	773369 ■ FL-09600	773374 ■ FL-07300	773348 ■ FL-07300	773353 ■ FL-06200
		STRUCTURÉ (STUTTURATO)	773389 ■ FL-09600	-	-	-	-

ATMOSPHÈRES

MYSTÈRE - SABLÉ



MYSTÈRE - PATINÉ



R10
(sablé)

R11
(structuré)

CLASSE B
(sablé)
(structuré)

DCOF>
0,42 Wet
(sablé)
(patiné)
(structuré)

BS EN 16165
ANNEX C
>36 wet
slider 4S
(structuré)

9 mm 3/8" ↑↓

GRES FINE PORCELLANATO
FINE PORCELAIN STONEWARE/GRES CERAME FIN/FEINSTEINZEUG-KOLLEKTIONEN/GRES PORCELANICO FINO
SQUADRATO - SQUARED - EQUARRI - REKTIFIZIERT - ESCUADRADO

9 mm 3/8" ↑↓	COLOR	SURFACE	60x120 23 ^{5/8"} x47 ^{1/4"}	80x80 31 ^{1/2"} x31 ^{1/2"}	40x80 15 ^{3/4"} x31 ^{1/2"}	60x60 23 ^{5/8"} x23 ^{5/8"}	30x60 11 ^{4/8"} x23 ^{5/8"}
		SABLÉ (NATURALE)	773345 ■ FL-09600	773381 ■ FL-09300	773386 ■ FL-06900	773360 ■ FL-06900	773366 ■ FL-05900
ATMOSPHÈRES	MYSTÈRE	PATINÉ (SMOOTH)	773340 ■ FL-09900	773371 ■ FL-09600	773376 ■ FL-07300	773350 ■ FL-07300	773355 ■ FL-06200
		STRUCTURÉ (STUTTURATO)	773391 ■ FL-09600	-	-	-	-



ATMOSPHÈRES OUTDOOR

Vantaggi tecnici - Technical advantages - Avantages techniques Technische Vorteile - Ventajas técnicas

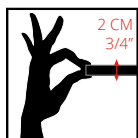

- Lastra monolitica compatta di spessore 2 cm squadrata e rettificata
- Compact monolithic slab 2 cm thick squared and rectified
- Dalle monolithique compacte de 2 cm d'épaisseur, équarrie et rectifiée
- Kompakte monolithische Platte, 2 cm dick, rechteckig und scharfkantig geschliffen
- Losa monolítica compacta de 2 cm de espesor, escuadrada y rectificada.

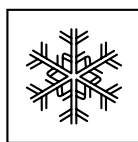

- INGELIVO
- FROST RESISTANT
- INGÉLIF
- FROSTBESTÄNDIG
- RESISTENTE A LA HELADA

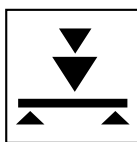

- ELEVATA RESISTENZA AI CARICHI STATICI
- HIGH STATIC LOAD RESISTANCE
- RÉSISTANT ÉLEVÉE AUX CHARGES STATIQUES
- HOHE STATISCHE BELASTBARKEIT
- ELEVADA RESISTENCIA A LAS CARGAS ESTÁTICAS

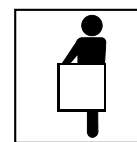

- FACILE DA POSARE
- EASY TO INSTALL
- FACILE À POSER
- VERLEGELEICHT
- FÁCIL DE COLOCAR



- ANTISCIVOLO R11
- ANTI SLIP R11
- ANTIDÉRAPANT R11
- RUTSCHFEST R11
- ANTIDESLIZANTE R11

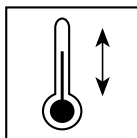

- RESISTENTE AGLI SBALZI TERMICI
- THERMAL SHOCK RESISTANT
- RÉSISTANT AUX ÉCARTS THERMIQUES
- TEMPERATURWECHSELBESTÄNDIG
- RESISTENTE A LAS OSCILACIONES TÉRMICAS



- FACILE DA PULIRE
- EASY TO CLEAN
- FACILE À NETTOYER
- REINIGUNGSLEICHT
- FÁCIL DE LIMPIAR

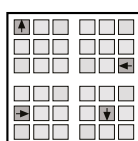

- RIMOVIBILE E RIUTILIZZABILE
- REMOVABLE AND REUSABLE
- DÉMONTABLE ET RÉUTILISABLE
- ENTFERNBAR UND WIEDERVERWENDBAR
- DESMONTABLE Y REUTILIZABLE



- INATTACCABILE DA AGENTI CHIMICI E MUFFE
- IMPERVIOUS TO ATTACK BY CHEMICALS OR MOULD
- RÉSISTANT AUX AGENTS CHIMIQUES ET AUX MOISSISSURES
- UNANGREIFBAR DURCH CHEMISCHE STOFFE UND SCHIMMEL
- RESISTENTE A LOS AGENTES QUÍMICOS Y A LOS MOHOS

Applicazioni - Applications - Applications - Verlegung - Aplicaciones

- Posa diretta su erba
- Direct installation on grass
- Pose direct sur de l'herbe
- Verlegung direkt auf Rasen
- Colocación directa sobre hierba

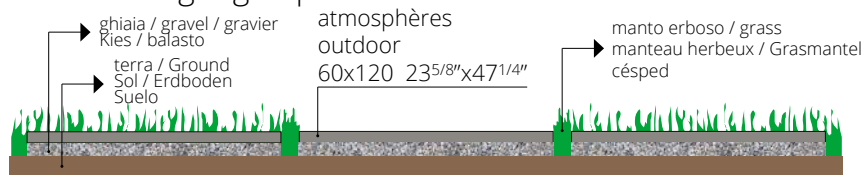

- Posa diretta su ghiaia
- Direct installation over gravel
- Pose direct sur du gravier
- Verlegung direkt auf Kies
- Colocación directa sobre grava

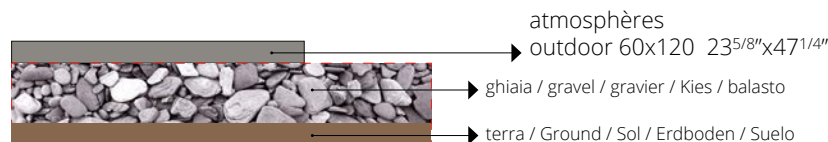

- Posa su massetto cementizio
- Installation on sand-cement screed
- Pose sur chape ciment
- Verlegung auf Zement-Unterbetonblock
- Colocación sobre contrapiso de hormigón

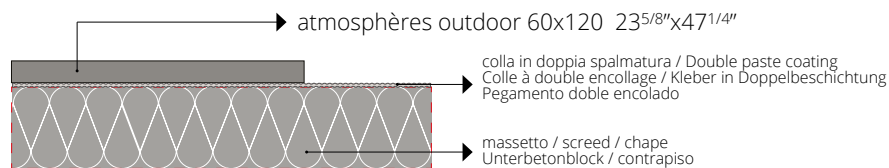

- Posa su piedini fissi o regolabili
- Installation on fixed or adjustable feet
- Pose sur pieds fixes ou réglables
- Verlegung auf feststehende oder regulierbare Füße
- Colocación sobre pies fijos o regulables

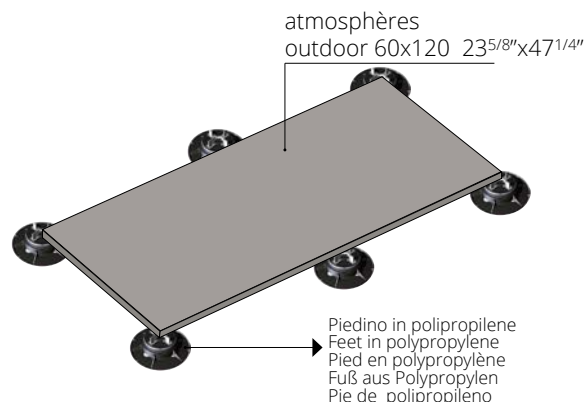

Per le specifiche di utilizzo dei sistemi sopraelevati vedi il sito florim.com
For the specifics on use of raised systems visit the site florim.com
Pour les caractéristiques d'utilisation des systèmes surélevés, voir le site florim.com
Für die Nutzungsbedingungen der Doppelbodensysteme siehe Webseite florim.com
Para las especificaciones de empleo de los sistemas sobreelevados consulte el sitio web florim.com

Le lastre ceramiche sono sottoposte a un trattamento di compattazione termica che assicura resistenza e durata nel tempo. Il bassissimo assorbimento d'acqua rende perciò il materiale ingelivo. Ciò può comportare ristagni d'acqua superficiali anche per materiale installato a regola d'arte. / Ceramic tiles undergo a compacting thermal treatment that ensures resistance and durability. The low level of water absorption makes the slabs frost resistant. This could result in superficial water stagnations even if materials are installed in a workmanlike manner. / Les carreaux de céramique subissent un traitement thermique de compactage qui assure résistance et durabilité. Le bas niveau d'absorption d'eau rend les dalles résistant au gel. Il pourrait en résulter des stagnations d'eau superficielles, même si les dalles ont été installées dans les règles de l'art. / Die Keramikplatten werden einer thermischen Verdichtung unterzogen, welche die Widerstandsfähigkeit und Langlebigkeit sichert. Die extrem niedrige Wasseraufnahme macht das Material frostsicher. Die hohe Materialdichte kann, auch bei einer perfekten Verlegung, eine längere Abtrochnungszeit von angestaumtem Wasser zur Folge haben. / Las baldosas cerámicas se someten a un tratamiento de compactación térmica que asegura resistencia y durabilidad. La baja absorción de agua hace que las baldosas resistan al hielo. Esto podría resultar en estancamientos superficiales de agua, incluso si los materiales están instalados según las reglas del arte.

LUMIÈRE



OMBRE





R11
CLASSE
A+B
(structuré)
BS EN 16165
ANNEX C
>36 wet
slider 4S

DCOF>
0,42 Wet

20 mm 3/4" ↑↓

GRES FINE PORCELLANATO

FINE PORCELAIN STONEWARE/GRES CERAME FIN/FEINSTEINZEUG-KOLLEKTIONEN/GRES PORCELANICO FINO
SQUADRATO - SQUARED - EQUARRI - REKTIFIZIERT - ESCUADRADO

20 mm 3/4" ↑↓	COLOR	SURFACE	60x120 23 ^{5/8"} x47 ^{1/4"}
	LUMIÈRE	STRUCTURÉ	773394 ■ FL-10300
	OMBRE	STRUCTURÉ	773395 ■ FL-10300

ATMOSPÈRES

	RESISTENZA ALLA FLESSIONE IN N/mm² N/mm ² FLEXURAL STRENGTH TEST / RESISTANCE A LA FLEXION EN N/mm ² / BIEGEFESTIGKEIT IN N/mm ² / RESISTENCIA A LA FLEXION EN N/mm ²	valore medio 52 N/mm²
	Forza di rottura in N (sp. > 7,5 mm) Breaking strength in N (thickness > 7,5 mm) / Force de rupture en N (ép. > 7,5 mm) / Bruchlast in N (Dicke > 7,5 mm) / Fuerza de rotura en N (gr. > 7,5 mm)	valore medio 14000 N

PEZZI SPECIALI

Special trims/Pièces spéciales/Formstücke
Piezas especiales

pag 194/197

LUMIÈRE

Product Certification
BUREAU VERITAS
Certification

Recycled material content certification



ATMOSPÈRES	scatola - box			pallet		
	pz	mq	kg	box	mq	kg
60x120 20mm	1	0,72	32,26	30	21,60	1000

ATMOSPHÈRES

9 mm 3/8" ↑↓	COLOR	SURFACE	30x30 11 ^{4/5"} x 11 ^{4/5"} pz/box 11
--------------	-------	---------	--



MIX
HARMONIE
GÉOMÉTRIES

harmonie patiné+harmonie
structuré+lumière canneté

773946
▲ FL-02700

ATMOSPHÈRES



MIX
CHARME
GÉOMÉTRIES

charme patiné+charme
structuré+ombre canneté

773947
▲ FL-02700

9 mm 3/8" ↑↓	COLOR	SURFACE	39,8x46 15 ^{2/3"} x 18 ^{1/9"} pz/box 4
--------------	-------	---------	---



HARMONIE HEXAGONE

SABLÉ

773948
▲ FL-03500



AURORE HEXAGONE

SABLÉ

773949
▲ FL-03500

ATMOSPHÈRES



CHARME HEXAGONE

SABLÉ

773950
▲ FL-03500



DÉSIR HEXAGONE

SABLÉ

773951
▲ FL-03500

9 mm 3/8" 

COLOR

SURFACE

80x80
31 1/2"x31 1/2"



HARMONIE TAPIS

SABLÉ

773952
■ FL-21500



AURORE TAPIS

SABLÉ

773953
■ FL-21500

ATMOSPHÈRES



CHARME TAPIS

SABLÉ

773954
■ FL-21500



DÉsir TAPIS

SABLÉ

773955
■ FL-21500

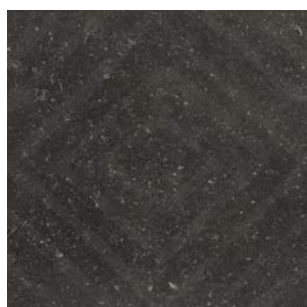

MYSTÈRE TAPIS

SABLÉ

773956
■ FL-21500

ATMOSPHERES

PEZZI SPECIALI/SPECIAL TRIMS/PIÈCES SPÉCIALES/FORMSTÜCKE/PIEZAS ESPECIALES

9 mm 3/8" ↑		COLOR	SURFACE	4,6x60 1 475/8" x 2 35/8"	33x120x3 1 3" x 4 7 1/4" x 1 1/8"	33x120x3 1 3" x 4 7 1/4" x 1 1/8"	33x120x3 1 3" x 4 7 1/4" x 1 1/8"
				battiscopa	gradino pz/box 2	angolo gradino dx pz/box 2	angolo gradino sx pz/box 2
ATMOSPHERES	HARMONIE	SABLÉ (NATURALE)		773939 ◆ FL-01600	773919 ▲ FL-20400	773924 ▲ FL-31100	773929 ▲ FL-31100
		PATINÉ (SMOOTH)		773934 ◆ FL-01600	773903 ▲ FL-20400	773908 ▲ FL-31100	773913 ▲ FL-31100
	AURORE	SABLÉ (NATURALE)		773940 ◆ FL-01600	773920 ▲ FL-20400	773925 ▲ FL-31100	773930 ▲ FL-31100
		PATINÉ (SMOOTH)		773935 ◆ FL-01600	773904 ▲ FL-20400	773909 ▲ FL-31100	773915 ▲ FL-31100
	DÉSIR	SABLÉ (NATURALE)		773943 ◆ FL-01600	773922 ▲ FL-20400	773927 ▲ FL-31100	773932 ▲ FL-31100
		PATINÉ (SMOOTH)		773937 ◆ FL-01600	773906 ▲ FL-20400	773911 ▲ FL-31100	773917 ▲ FL-31100
	CHARME	SABLÉ (NATURALE)		773942 ◆ FL-01600	773921 ▲ FL-20400	773926 ▲ FL-31100	773931 ▲ FL-31100
		PATINÉ (SMOOTH)		773936 ◆ FL-01600	773905 ▲ FL-20400	773910 ▲ FL-31100	773916 ▲ FL-31100
	MYSTÈRE	SABLÉ (NATURALE)		773944 ◆ FL-01600	773923 ▲ FL-20400	773928 ▲ FL-31100	773933 ▲ FL-31100
		PATINÉ (SMOOTH)		773938 ◆ FL-01600	773907 ▲ FL-20400	773912 ▲ FL-31100	773918 ▲ FL-31100

FLORIM OVERSIZE
magnum

120x280/120x240/120x120/60x120

Specifica Imballo pag.
Packaging specifications on page
Spécifications d'emballage à page
Verpackungsdetail Seite
Especificaciones de embalaje a la página
204/205

9 mm 3/8" ↑

Product Certification
BUREAU VERITAS
Certification



Recycled material content certification

Per un effetto ottimale della posa, florim suggerisce di mantenere 2 mm di fuga per pose monoformato e 3 mm per combinare formati misti - For optimal installation results, florim recommends maintaining a joint of 2 mm 1/12" for single format installations and 3 mm 1/8" to combine mixed formats. - Pour réaliser une pose parfaite, florim suggère de maintenir 2 mm de joint pour la pose des monoformats, et 3 mm pour les combinaisons de formats mixtes. - Um einen optimalen effekt beim verlegen zu erzielen empfiehlt florim eine 2 mm fuge bei einformatigen verlegungen und 3 mm fuge bei formatkombinationen Para lograr los máximos resultados en la posa del producto, florim aconseja 2 mm de junta en aplicaciones monoformato y 3 mm en combinaciones de formatos mixtos

In relazione alle differenti tecnologie produttive l'accostamento di prodotti con spessori diversi potrebbe presentare delle disomogeneità, se ne sconsiglia pertanto l'abbinamento. / Due to the different production technologies, contiguous installation of products with different thickness may give a non-homogeneous result. For this reason we do not recommend this option. / Vu que différentes technologies de production sont utilisées avec des épaisseurs différentes, des problèmes d'homogénéité pourraient se présenter, il est donc déconseillé de les poser ensemble. / Wegen unterschiedlicher Produktionstechnologien können die Fliesen mit verschiedenen Materialstärken optische Differenzen aufweisen. Von einem direkten Aneinanderlegen wird deshalb abgeraten. / Dadas las diferentes tecnologías productivas, la combinación de productos de diferentes espesores podría dar lugar a heterogeneidad, por lo que se desaconseja mezclarlas.

ATMOSPHERES	scatola - box			pallet		
	pz	mq	kg	box	mq	kg
60x120	2	1,44	28,08	30	43,20	870
80x80	2	1,28	24,96	40	51,20	1030
40x80	3	0,96	18,53	56	53,76	1070
60x60	3	1,08	21,06	40	43,20	870
30x60	6	1,08	20,84	40	43,20	860
80x80 tapis	2	1,28	27,26	20	25,60	580

ATMOSPHERES	scatola - box			pallet		
	pz	ml	kg	box	mq	kg
4,6x60 battiscopa	14	8,40	8,40	-	-	-





ÉTOILE

gres porcellanato colorato in massa
coloured body porcelain stoneware
grès cérame colore dans la masse
durchgefärbte feinsteinzeug
gres porcelánico coloreado en masa





ÉTOILE

La storia e il futuro sono il binario lungo cui Luxury design ha improntato la sua ricerca estetica, guardare all'antico con uno sguardo nuovo è il cuore del progetto. Una sfida in cui l'eccellenza vince sul tempo. **Étoile** è un magico equilibrio tra segni e colori che stimolano la sensorialità invitando al tatto lo spettatore che si trova di fronte alla sua raffinata intensità cromatica. La sintesi perfetta di una eleganza che nasce dalla sorprendente varietà della natura e dalla tecnologia produttiva fortemente all'avanguardia. Una intrinseca vocazione decorativa per una serie che si ispira alle inusuali venature di un minerale pregiato ed estremamente raro, selezionato tra i più inediti. Superfici morbide e luminose accolgono nuances che muovono dal bianco al grigio arrivando fino ai toni più decisi dei verdi che si sviluppano esaltando grafiche suggestive.

History and the future are the two paths along which Luxury design has pursued its aesthetic research, so that looking at the past from a new perspective lies at the heart of this project. It's a challenge where excellence wins over time. **Étoile** is a magical balance of symbols and colours that stimulate the senses, inviting the viewer who is gazing at its refined depth of colour to touch it. This is the perfect synthesis of an elegance stemming from the amazing variety to be found in nature and from extremely cutting-edge production technology – an intrinsic decorative vocation for a range inspired by the unusual veining of a highly-prized and very rare mineral, selected from the least-known of them. Soft, bright surface-finishes have nuances ranging from white to grey and right down to more decisive shades of green which, as they develop, highlight suggestive patterns.

C'est sur l'histoire et le futur que Luxury design a basé sa recherche esthétique en modernisant le passé dans chaque projet. Un défi où l'excellence l'emporte sur le temps. **Étoile** est un équilibre magique entre les signes et les couleurs qui stimulent les sens en invitant au toucher le spectateur qui se trouve devant son intensité chromatique raffinée. La synthèse parfaite d'une élégance qui naît de la variété surprenante de la nature et de la technologie de production fortement innovante. Une vocation décorative intrinsèque pour une série qui s'inspire des marbrures insolites d'un minerale précieux et extrêmement rare, sélectionné parmi les plus inédits. Des surfaces douces et lumineuses accueillent des nuances qui passent du blanc au gris pour arriver à des tonalités vertes plus intenses dont le développement exalte des graphismes suggestifs.

Geschichte und Zukunft sind der Weg, den Luxury design mit seiner ästhetischen Forschungstätigkeit begeht. Ein neuer Blick auf das Alte, das ist das Herzstück des Projekts. Eine Herausforderung, bei der die hervorragende Qualität gewinnbringend ist. **Étoile** ist eine magische Balance zwischen Zeichen und Farben, die die Sinne anregt und den Betrachter mit der edlen Farbintensität zur Berührung einlädt. Die perfekte Synthese einer Eleganz, die sich aus der überraschenden Vielfalt der Natur und der überaus innovativen Produktionstechnologie ergibt. Eine innewohnende dekorative Berufung für eine Serie, die von der ungewöhnlichen Äderung eines kostbaren und extrem seltenen Minerals inspiriert wird, das unter den vollkommen neuartigen Materialien ausgewählt wurde. Weiche und helle Oberflächen heißen Nuancen willkommen, die von Weiß über Grau bis hin zu kräftigeren Grüntönen reichen, die erhebende, stimmungsvolle Grafiken hervorheben.

La historia y el futuro son los dos elementos en los que Luxury design ha centrado su investigación estética, mirar a lo antiguo con una mirada nueva es la esencia del proyecto. Un desafío en el que la excelencia gana al tiempo. **Étoile** es un equilibrio mágico entre signos y colores que estimulan la sensorialidad incitando el tacto del espectador que se encuentra frente a su refinada intensidad cromática. La síntesis perfecta de una elegancia que nace de la sorprendente variedad de la naturaleza y de la tecnología productiva muy a la vanguardia. Una vocación decorativa intrínseca para una serie que se inspira en las vetas inusuales de un mineral preciado y extremadamente raro, seleccionado de entre los más inéditos. Superficies suaves y luminosas acogen tonos que van del blanco al gris llegando incluso a los tonos más intensos de los verdes que se desarrollan destacando gráficas sugestivas.

ÉTOILE

ÉTOILE RENOIR



ÉTOILE GRIS

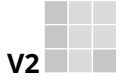

DCOF>
0,42 Wet
(matte)

9 mm 3/8" ↑↓

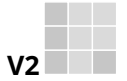





DCOF>
0,42 Wet
(matte)

6 mm 1/4" ↑↓

FLORIM OVERSIZE
magnUm

GRES PORCELLANATO COLORATO IN MASSA/COLOURED BODY PORCELAIN STONEWARE
GRÉS CÉRAME COLORE DANS LA MASSE/DURCHGEFÄRBTE FEINSTEINZEUG/GRES PORCELÁNICO COLOREADO EN MASA
SQUADRATO - SQUARED - EQUARRI - REKTIFIZIERT - ESCUADRADO

				80x180 31 ^{1/2} "x70 ^{5/7} "	80x80 31 ^{1/2} "x31 ^{1/2} "	60x120 23 ^{5/8} "x47 ^{1/4} "	60x60 23 ^{5/8} "x23 ^{5/8} "
ÉTOILE		ÉTOILE RENOIR	GLOSSY	761661 ■ FL-11900	761670 ■ FL-10800	761679 ■ FL-11300	761695 ■ FL-09100
			MATTE	761657 ■ FL-10500	761665 ■ FL-09300	761674 ■ FL-09900	761691 ■ FL-07300
		ÉTOILE GRIS	GLOSSY	761662 ■ FL-11900	761671 ■ FL-10800	761680 ■ FL-11300	761696 ■ FL-09100
			MATTE	761658 ■ FL-10500	761667 ■ FL-09300	761676 ■ FL-09900	761692 ■ FL-07300
				120x280 47 ^{1/4} "x110 ^{1/4} "	120x240 47 ^{1/4} "x94 ^{1/2} "	120x120 47 ^{1/4} "x47 ^{1/4} "	60x120 23 ^{5/8} "x47 ^{1/4} "
ÉTOILE		ÉTOILE RENOIR	GLOSSY	761727 ■ FL-15100	761737 ■ FL-14000	761749 ■ FL-12400	761773 ■ FL-11300
			MATTE	761723 ■ FL-12400	761731 ■ FL-11300	761743 ■ FL-09700	761767 ■ FL-09100
		ÉTOILE GRIS	GLOSSY	761728 ■ FL-15100	761738 ■ FL-14000	761750 ■ FL-12400	761774 ■ FL-11300
			MATTE	761724 ■ FL-12400	761732 ■ FL-11300	761744 ■ FL-09700	761768 ■ FL-09100

ÉTOILE CRÈME



ÉTOILE TROPICAL



DCOF >
0,42 Wet
(matte)

9 mm 3/8" ↑↓





DCOF >
0,42 Wet
(matte)

6 mm 1/4" ↑↓

FLORIM OVERSIZE
magnum

GRES PORCELLANATO COLORATO IN MASSA/COLOURED BODY PORCELAIN STONEWARE
GRÈS CÉRAME COLORE DANS LA MASSE/DURCHGEFÄRBTE FEINSTEINZEUG/GRES PORCELÁNICO COLOREADO EN MASA
SQUADRATO - SQUARED - EQUARRI - REKTIFIZIERT - ESCUADRADO

9 mm 3/8" ↑↓		COLOR	SURFACE	80x180 31 1/2" x 70 6/7"	80x80 31 1/2" x 31 1/2"	60x120 23 5/8" x 47 1/4"	60x60 23 5/8" x 23 5/8"
ÉTOILE		ÉTOILE CRÈME	GLOSSY	761663 ■ FL-11900	761672 ■ FL-10800	761681 ■ FL-11300	761697 ■ FL-09100
			MATTE	761659 ■ FL-10500	761668 ■ FL-09300	761677 ■ FL-09900	761693 ■ FL-07300
		ÉTOILE TROPICAL	GLOSSY	761664 ■ FL-11900	761673 ■ FL-10800	761682 ■ FL-11300	761698 ■ FL-09100
			MATTE	761660 ■ FL-10500	761669 ■ FL-09300	761678 ■ FL-09900	761694 ■ FL-07300
6 mm 1/4" ↑↓		COLOR	SURFACE	120x280 47 1/4" x 110 1/4"	120x240 47 1/4" x 94 1/2"	120x120 47 1/4" x 47 1/4"	60x120 23 5/8" x 47 1/4"
ÉTOILE		ÉTOILE CRÈME	GLOSSY	761729 ■ FL-15100	761739 ■ FL-14000	761751 ■ FL-12400	761775 ■ FL-11300
			MATTE	761725 ■ FL-12400	761733 ■ FL-11300	761745 ■ FL-09700	761769 ■ FL-09100

ÉTOILE

ÉTOILE SYMPHONIE





ÉTOILE ILLUSION



V3
DCOF >
0,42 Wet
(matte)

6 mm 1/4" ↑
FLOHM OVERSIZE
magnUm

GRES PORCELLANATO COLORATO IN MASSA/COLOURED BODY PORCELAIN STONEWARE
GRÈS CÉRAME COLORE DANS LA MASSE/DURCHGEFÄRBTE FEINSTEINZEUG/GRES PORCELÁNICO COLOREADO EN MASA
SQUADRATO - SQUARED - EQUARRI - REKTIFIZIERT - ESCUADRADO

			120x240 47 ^{1/4} "x94 ^{1/2} "	120x120 47 ^{1/4} "x47 ^{1/4} "	60x120 23 ^{5/8} "x47 ^{1/4} "
ÉTOILE		ÉTOILE SYMPHONIE	GLOSSY 761741 ■ FL-14000	761753 ■ FL-12400	761777 ■ FL-11300
			MATTE 761735 ■ FL-11300	761747 ■ FL-09700	761771 ■ FL-09100
		ÉTOILE ILLUSION	GLOSSY 761742 ■ FL-14000	761754 ■ FL-12400	761778 ■ FL-11300
			MATTE 761736 ■ FL-11300	761748 ■ FL-09700	761772 ■ FL-09100



ÉTOILE

9 mm 3/8" ↑↓		COLOR	SURFACE	30x30 11 ^{4/5"} x11 ^{4/5"} mosaico tessere 3x15 pz/box 11	30x30 11 ^{4/5"} x11 ^{4/5"} mosaico mix tessere 3x3 pz/box 9
ÉTOILE		ÉTOILE RENOIR	GLOSSY	761847 ▲ FL-02200	761839 ▲ FL-04900
			MATTE	761843 ▲ FL-02100	
		ÉTOILE GRIS	GLOSSY	761848 ▲ FL-02200	761840 ▲ FL-04900
			MATTE	761844 ▲ FL-02100	
		ÉTOILE CRÈME	GLOSSY	761849 ▲ FL-02200	761841 ▲ FL-04900
			MATTE	761845 ▲ FL-02100	
		ÉTOILE TROPICAL	GLOSSY	761850 ▲ FL-02200	761842 ▲ FL-04900
			MATTE	761846 ▲ FL-02100	

PEZZI SPECIALI/SPECIAL TRIMS/PIÈCES SPÉCIALES/FORMSTÜCKE/PIEZAS ESPECIALES

9 mm 3/8" ↑↓		COLOR	SURFACE	4,6x60 1 ^{4/5"} x23 ^{5/8"} battiscopa	33x120x3 13 ^{1/4"} x47 ^{1/4"} x1 ^{1/8"} gradino pz/box 2
ÉTOILE		ÉTOILE RENOIR	GLOSSY	761855 ◆ FL-01600	761835 ▲ FL-22600
			MATTE	761851 ◆ FL-01600	761831 ▲ FL-20400
		ÉTOILE GRIS	GLOSSY	761856 ◆ FL-01600	761836 ▲ FL-22600
			MATTE	761852 ◆ FL-01600	761832 ▲ FL-20400
		ÉTOILE CRÈME	GLOSSY	761857 ◆ FL-01600	761837 ▲ FL-22600
			MATTE	761853 ◆ FL-01600	761833 ▲ FL-20400
		ÉTOILE TROPICAL	GLOSSY	761858 ◆ FL-01600	761838 ▲ FL-22600
			MATTE	761854 ◆ FL-01600	761834 ▲ FL-20400

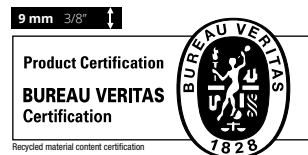

Per un effetto ottimale della posa, florim suggerisce di mantenere 2 mm di fuga per pose monoformato e 3 mm per combinare formati misti. - For optimal installation results, florim recommends maintaining a joint of 2 mm (1/16") for single format installations and 3 mm (1/8") to combine mixed formats. - Pour réaliser une pose parfaite, florim suggère de maintenir 2 mm de joint pour la pose des monoformats, et 3 mm pour les combinaisons de formats mixtes. - Um einen optimalen Effekt beim Verlegen zu erzielen empfiehlt florim eine 2 mm fugе bei einformatigen Verlegungen und 3 mm fugе bei formatkombinationen. Para lograr los máximos resultados en la posa del producto, florim aconseja 2 mm de junta en aplicaciones monoformato y 3 mm en combinaciones de formatos mixtos.

In relazione alle differenti tecnologie produttive l'accostamento di prodotti con spessori diversi potrebbe presentare delle disomogeneità, se ne sconsiglia pertanto l'abbinamento. / Due to the different production technologies, contiguous installation of products with different thickness may give a non-homogeneous result. For this reason we do not recommend this option. / Vu que différentes technologies de production sont utilisées avec des épaisseurs différentes, des problèmes d'homogénéité pourraient se présenter, il est donc déconseillé de les poser ensemble. / Wegen unterschiedlicher Produktionstechnologien können die Fliesen mit verschiedenen Materialstärken optische Differenzen aufweisen. Von einem direkten Aneinanderlegen wird deshalb abgeraten. / Dadas las diferentes tecnologías productivas, la combinación de productos de diferentes espesores podría dar lugar a heterogeneidad, por lo que se desaconseja mezclarlas.

ÉTOILE	scatola - box			pallet		
	pz	mq	kg	box	mq	kg
80x180	2	2,88	57,60	20	57,60	1210
80x80	2	1,28	24,96	40	51,20	1030
60x120	2	1,44	28,08	30	43,20	870
60x60	3	1,08	21,06	40	43,20	870

ÉTOILE	scatola - box			pallet		
	pz	ml	kg	box	mq	kg
4,6x60 battiscopa	14	8,40	8,40	-	-	-

6 mm 1/4" ↑↓				30x30 11 4/5"x11 4/5" mosaico tessere 7,5x7,5 pz/box 11	30x30 11 4/5"x11 4/5" muretto tessere 7,5x15 pz/box 11
		COLOR	SURFACE		
ÉTOILE		ÉTOILE RENOIR	GLOSSY	761825 ▲ FL-02100	761813 ▲ FL-02100
			MATTE	761819 ▲ FL-01800	761807 ▲ FL-01800
		ÉTOILE GRIS	GLOSSY	761826 ▲ FL-02100	761814 ▲ FL-02100
			MATTE	761820 ▲ FL-01800	761808 ▲ FL-01800
		ÉTOILE CRÈME	GLOSSY	761827 ▲ FL-02100	761815 ▲ FL-02100
			MATTE	761821 ▲ FL-01800	761809 ▲ FL-01800
		ÉTOILE SYMPHONIE	GLOSSY	761829 ▲ FL-02100	761817 ▲ FL-02100
			MATTE	761823 ▲ FL-01800	761811 ▲ FL-01800
		ÉTOILE ILLUSION	GLOSSY	761830 ▲ FL-02100	761818 ▲ FL-02100
			MATTE	761824 ▲ FL-01800	761812 ▲ FL-01800

PEZZI SPECIALI/SPECIAL TRIMS/PIÈCES SPÉCIALES/FORMSTÜCKE/PIEZAS ESPECIALES

6 mm 1/4" ↑↓				4,6x80 1 4/5"x3 1/2" battiscopa
		COLOR	SURFACE	
ÉTOILE		ÉTOILE RENOIR	GLOSSY	761803 ◆ FL-01800
			MATTE	761799 ◆ FL-01800
		ÉTOILE GRIS	GLOSSY	761804 ◆ FL-01800
			MATTE	761800 ◆ FL-01800
		ÉTOILE CRÈME	GLOSSY	761805 ◆ FL-01800
			MATTE	761801 ◆ FL-01800

FLORIM OVERSIZE
magnlum

120x280/120x240/120x120/60x120

Specifica Imballo pag.
Packaging specifications on page
Spécifications d'emballage à page
Verpackungsdetail Seite
Especificaciones de embalaje a la página
204/205

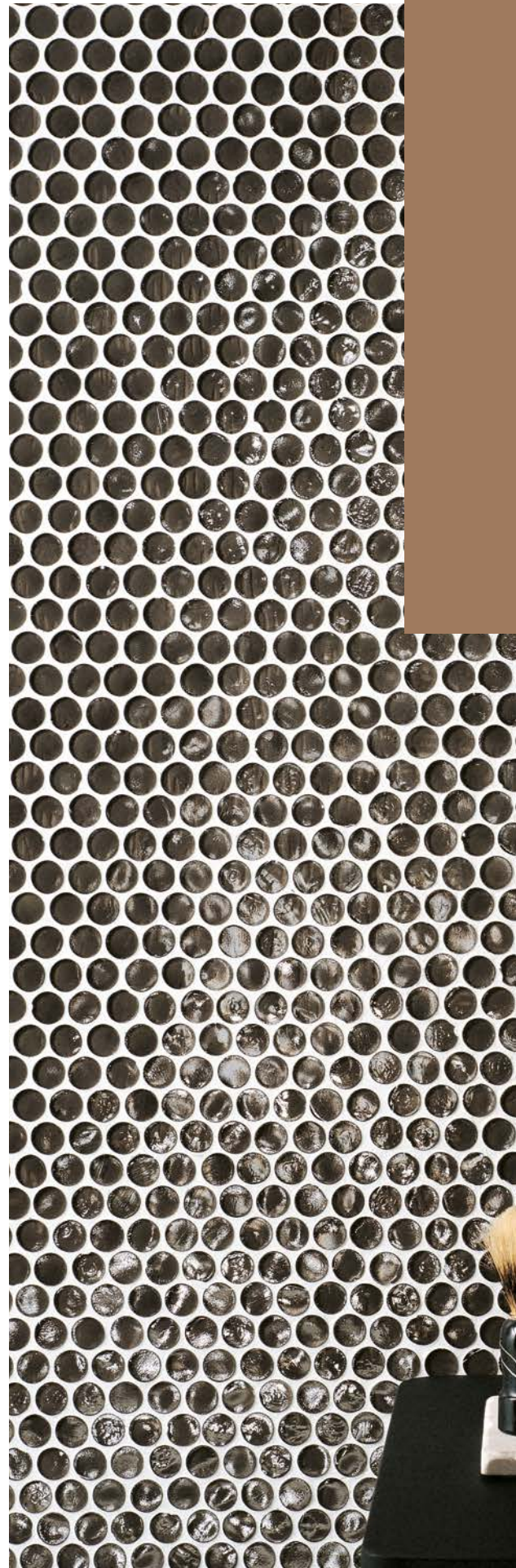

EXTRA LIGHT

mosaico di vetro
glass mosaic tiles
mosaïque en verre
glasmaik
mosaico vitreo





EXTRA LIGHT

Colore e trasparenza all'insegna di una modularità che permette di rivestire qualsiasi superficie. La ricchezza della cartella colori s'immerge in una dimensione di chiara lucentezza che ha la capacità di vestire l'urbano contemporaneo.

Colour and transparency for a modularity that makes it possible to cover any type of surface. The wide colour selection is immersed in a dimension of clear brilliance to adorn contemporary urban contexts.

Couleur et transparence réunies sous le signe d'une modularité qui permet de recouvrir toutes les surfaces. L'éventail de couleurs plonge dans une dimension brillante et claire, en mesure de revêtir l'urbain contemporain.

Farbe und Transparenz im Zeichen einer Modularität, welche die Verkleidung einer jeden Oberfläche erlaubt. Die Reichhaltigkeit der Farbkarte taucht ein in eine Dimension von klarem Glanz, der in der Lage ist, die zeitgenössische städtische Umwelt einzukleiden.

Color y transparencia bajo el estandarte de una modularidad que permite revestir cualquier superficie. La riqueza de la carta de colores se sumerge en una dimensión de nítida luminosidad con la capacidad de ofrecer una decoración urbana contemporánea.

EXTRA LIGHT

WHITE MOSAICO CIRCLE



DIAMOND MOSAICO CIRCLE

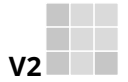

V2
CLASSE
A+B+C
DIN 51097

OYSTER MOSAICO CIRCLE



ZINC MOSAICO CIRCLE



JADE MOSAICO CIRCLE



LIME MOSAICO CIRCLE



MOSAICO DI VETRO

GLASS MOSAIC TILES/MOSAÏQUE EN VERRE/GLASMOSAÏK/MOSAICO VÍTREO

4,3 mm \updownarrow 1.50"	COLOR	29,5x27,7 11 ^{3/5} "x11" Ø 1,8 cm 3/4"
	WHITE	735614 ▲ FL-01900
	DIAMOND	735613 ▲ FL-01900
	OYSTER	735615 ▲ FL-01900
	ZINC	735611 ▲ FL-01900
	JADE	735612 ▲ FL-01900
	LIME	735610 ▲ FL-01900

EXTRA LIGHT

MOSAICO

montato su pellicola trasparente
mounted on transparent film
monté sur film transparent
auf transparenter Folie montiert
montado en una película transparente

MINK MOSAICO CIRCLE



MOU MOSAICO CIRCLE



OCHER MOSAICO CIRCLE

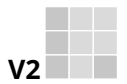

V2

CLASSE
A+B+C
DIN 51097

MOSAICO DI VETRO

GLASS MOSAIC TILES/MOSAÏQUE EN VERRE/GLASMOSAÏK/MOSAICO VÍTREO

4,3 mm ^{1.5/8"}	COLOR	29,5x27,7 11 ^{3/5"} x11" Ø 1,8 cm 3/4"
	MINK	735843 ▲ FL-01900
EXTRA LIGHT		MOU 735844 ▲ FL-01900
		OCHER 735842 ▲ FL-01900

MOSAICO

montato su pellicola trasparente
mounted on transparent film
monté sur film transparent
auf transparenter Folie montiert
montado en una película transparente

Per le informazioni sulla posa consultare il sito florim.com
For installation information please, visit the website florim.com
Pour plus d'informations sur l'installation visitez le site florim.com
Informationen zur Installation entnehmen Sie unserer Website florim.com
Para más información de instalación, visite el sitio web florim.com

EXTRA LIGHT	scatola - box			pallet		
	pz	mq	kg	box	mq	kg
29,5x27,7	11	-	8,00	-	-	-



GOLD

gres porcellanato decorato
decorated porcelain tiles
grès cérame décoré
verziertes feinsteinzeug
gres porcelánico decorado





GOLD

L'antico decoro a foglia d'oro, utilizzato per stucchi e mobili preziosi, viene aggiornato e reinterpretato da Luxury design.

Luxury design brings traditional gold leaf decoration, used for fine mouldings and furniture, right up to date.

Le décor antique à la feuille d'or, que l'on utilisait pour dorer les stucs et les meubles précieux, est remis au goût du jour et réinterprété par Luxury design.

Das antike Blattgold-Dekor, das für Stuckwerke und wertvolle Möbel verwendet wurde, wird von Luxury design aktualisiert und neu interpretiert.

La antigua decoración con pan de oro, utilizada en estucados y muebles de valor, ha sido reinterpretada y modernizada por Luxury design.

GOLD

GOLD



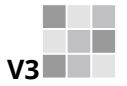
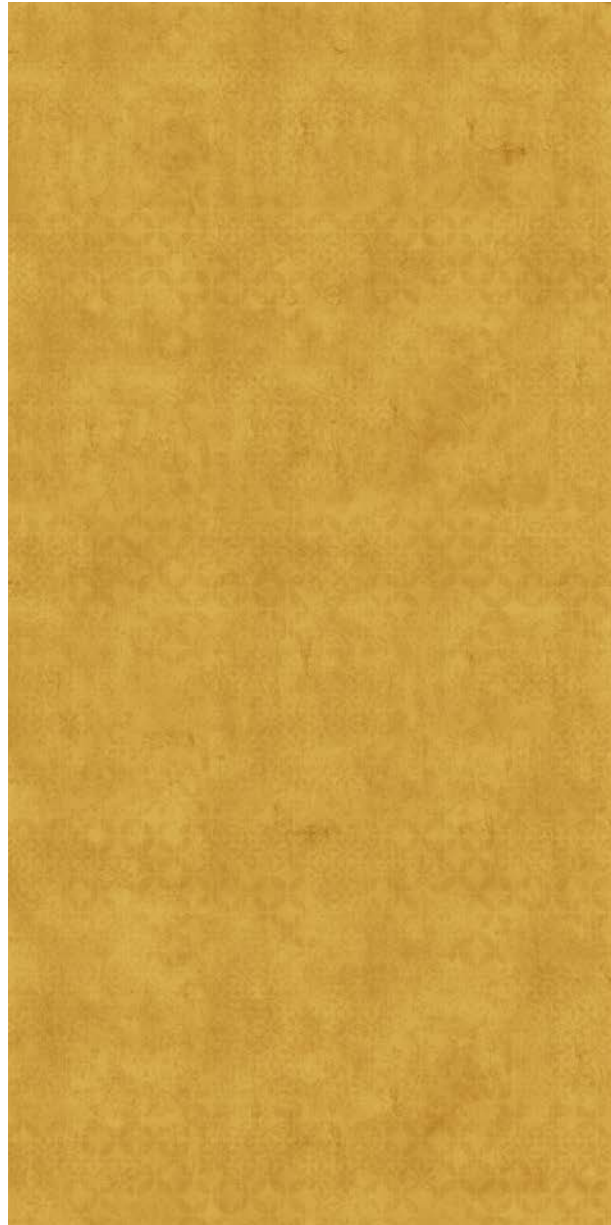

GOLD ARABESCATO



V3

6 mm 1/4" ↑↓

GRES PORCELLANATO DECORATO/DECORATED PORCELAIN TILES
GRÈS CÉRAMÉ DÉCORÉ/VERZIERTES FEINSTEINZEUG/ GRES PORCELÁNICO DECORADO
SQUADRATO - SQUARED - EQUARRI - REKTIFIZIERT - ESCUADRADO

6 mm 1/4" ↑↓		COLOR	SURFACE	120x280 47 ^{1/4"} x110 ^{1/4"}	60x120 23 ^{5/8"} x47 ^{1/4"}	10x60 4"x23 ^{5/8"}
GOLD		GOLD	GLOSSY	778070 ■ FL-55000	778072 ■ FL-52500	778074 ▲ FL-05800
		GOLD ARABESCATO	GLOSSY	778071 ■ FL-55000	778073 ■ FL-52500	-

GOLD	scatola - box			pallet		
	pz	mq	kg	box	mq	kg
60x120	2	1,44	20,85	20	28,80	450
10x60	16	0,96	9,60	48	46,08	490

FLORIM OVERSIZE
magnUm

120x280
Specifica Imballo pag.
Packaging specifications on page
Spécifications d'emballage à page
Verpackungsdetail Seite
Especificaciones de embalaje a la página
204/205

GRES PORCELLANATO DECORATO

DECORATED PORCELAIN TILES/GRÉS CÉRAMÉ DÉCORÉ/VERZIERTES FEINSTEINZEUG/GRES PORCELÁNICO DECORADO

AVVERTENZE / WARNINGS / AVERTISSEMENTS / HINWEISE / ADVERTENCIAS

<p>INDICAZIONI GENERALI GENERAL INSTRUCTIONS INDICATIONS GÉNÉRALES ALLGEMEINE HINWEISE INDICACIONES GENERALES</p>	<p>Florim indica di stoccare il materiale in magazzini coperti o al riparo da agenti atmosferici, coprendo il materiale con cappucci protettivi. È NECESSARIO EVITARE OGNI TIPO DI STROFINAMENTO O TRAUMA SUPERFICIALE DELLA LASTRA DURANTE TUTTE LE FASI DI MOVIMENTAZIONE POSA E STUCCATURA. I prodotti in gres porcellanato decorato sono realizzati con una tecnologia produttiva differente dai prodotti in gres porcellanato tradizionale. Nel caso in cui si intenda posare le due tipologie di materiale nello stesso ambiente si potrebbero verificare differenze di aspetto superficiale e "punto di colore". / Florim recommends storing the material in indoor warehouses or protected from the weather, covered with protective hoods. CARE MUST BE TAKEN TO PREVENT ANY RUBBING OF OR KNOCKS ON THE SURFACE OF THE SLAB THROUGHOUT ALL HANDLING, INSTALLATION AND GROUTING PHASES. The decorated porcelain stoneware products are made with a production technology which differs from traditional porcelain stoneware production. If you plan to install the two types of material in the same area, there could be differences in surface appearance and "color point". Florim precisa di stoccar il materiale dentro a fabbrici o intermperies, in le recouvert d'une protecteur de la surface de la dalle. PROTECCIÓN DE LOS MATERIALES EN LOS ENTORNOS DE LOS ATMÓSFERICOS. CUIDE LOS ENTORNOS DE LA MANUTENCIÓN Y LA EJECUCIÓN DE LOS JOINTS. Les produits en grés céramé décorés sont fabriqués à l'aide d'une technologie de production différente des produits en grés céramé traditionnels. Si vous avez l'intention de poser les deux types de matériaux dans la même pièce, il pourrait y avoir des différences d'aspect de surface et de "point de couleur". / Florim empfiehlt, das Material in geschlossenen Lagern bzw. vor Witterung geschützt aufzubewahren und mit Schutzplanen abzudecken. BEI HANDLING, VERLEGUNG UND VERFUGUNG SIND REIBEKONTAKTE UND VERLETZUNGEN DER OBERFLÄCHE ZU VERMEIDEN. Die dekorierten Feinsteinzeugprodukte werden mit einer anderen Produktionstechnologie hergestellt, als die traditionellen Feinsteinzeugprodukte. Wenn Sie die beiden Materialien in derselben Umgebung verlegen möchten, kann es zu Unterschieden in Oberflächen und Farbtönen kommen. Florim indica que el material debe guardarse, tapado con capuchas de protección, en almacenes cubiertos o al amparo de los agentes atmosféricos. DURANTE TODAS LAS FASES DE DESPLAZAMIENTO, COLOCACIÓN Y REJUNTADO EVITESE CAUSAR CUALQUIER TIPO DE ROZAMIENTO O DE TRAUMA SOBRE LA SUPERFICIE DE LA PLACA. Los productos de gres porcelánico decorado se elaboran con una tecnología de producción diferente a los productos tradicionales de gres porcelánico. En el caso tal que se requiera colocar los dos tipos de material en el mismo entorno, pueden haber diferencias en la apariencia de la superficie y el "punto de color".</p>
<p>DESTINAZIONE D'USO RECOMMENDED APPLICATIONS DOMAINE D'APPLICATION ANWENDUNGSBEREICHE USO PREVISTO</p>	<p>Lastre decorate con innovative tecniche artigianali destinate esclusivamente al rivestimento di pareti interne. Eventuali piccole imperfezioni sono da considerarsi caratteristica propria di prodotto dovuta al processo produttivo. Questa innovativa tecnica decorativa migliora la definizione e la profondità dei colori, rendendo la resistenza superficiale all'abrasione meno performante rispetto al gres porcellanato tradizionale. Per questo motivo è necessario attenersi alle istruzioni riportate negli imballi (qualora non fossero presenti, è possibile consultare il sito internet). Il materiale è utilizzabile anche come rivestimento della parete della doccia. In questa destinazione d'uso, per la corretta posa in opera, Florim raccomanda di installare solo lastre intere o posizionare i tagli della lastra non a contatto con il piatto doccia. In caso di utilizzo come backslash, Florim richiede l'installazione delle lastre a una distanza minima di 20 cm dai fuochi del piano cottura. Si consiglia l'utilizzo del materiale come rivestimento di camini, stufe e, più in generale, la posa in prossimità di fonti di calore. / Slabs decorated by innovative hand techniques intended only for covering indoor walls. Any minor flaws are an intrinsic characteristic of the product, due to the production process. This innovative decorative technique improves the definition and depth of the colours but reduces resistance to surface abrasion compared to standard porcelain stoneware. The instructions provided inside the packaging must therefore be complied with (if not found, refer to the website). The material can also be used to cover the walls of showers. For this intended use, for correct installation, Florim advises you to install whole slabs only, or to ensure that cut edges of slabs are not in contact with the shower tray. In case of use as a backslash, Florim specifies that slabs must be installed at least 20 cm from hot burners. The material is not recommended for use for covering fireplaces or stoves, or for installation close to heat sources in general. / Dalles décorées par des techniques artisanales modernes, à utiliser exclusivement pour le revêtement des murs intérieurs. Les petites imperfections éventuelles doivent être considérées comme des caractéristiques inhérentes au produit. Cette innovativa technique décorative améliore la définition et la profondeur des couleurs, mais donne à la surface une résistance à l'abrasion inférieure par rapport au grés céramé traditionnel. Pour cette raison, les instructions contenues dans les emballages doivent être suivies à la lettre (si la boîte ne les contient pas, il est possible de consulter le site Internet). Le produit peut être posé aussi sur le mur de la douche. Dans ce cas, pour un bon résultat de pose, Florim conseille d'installer uniquement des dalles entières ou de ne pas mettre les découpes de la dalle en contact avec le receveur. Si les dalles sont posées en dossier, Florim préconise de ne pas les placer à moins de 20 cm des feux de la table de cuisson. Il est déconseillé d'utiliser le produit pour revêtir des cheminées, des poêles et, de manière plus générale, de le poser à proximité de sources de chaleur. / Dekorierte Platten, hergestellt mit modernen Handwerkstechniken, ausschließlich für die Wandverkleidung im Innenbereich. Eventuelle geringfügige Unregelmäßigkeiten sind keine Mängel, sondern ein typisches, verfahrenstechnisch bedingtes Produktmerkmal. Dieses innovative Dekorationsverfahren verbessert die Farbtiefe und die Farbtiefe der Oberflächen, was zu einer geringeren Abriebfestigkeit gegenüber herkömmlichem Feinsteinzeug führt. Aus diesem Grund beachten Sie bitte genau die beigegebene Anleitung (sollten diese nicht vorhanden sein, informieren Sie sich bitte auf der Website). Das Material kann auch für die Wandverkleidung von Duschnischen verwendet werden. In diesem Fall empfiehlt Florim, nur ganze Platten zu verlegen bzw. die Schnittflächen der Platte nicht im Kontakt mit der Duschwanne zu verlegen. Bei Verwendung für Fliesenspiegel soll der Abstand der Platten von den Herdstellen des Kochfelds mindestens 20 cm betragen. Die Verwendung der Platten für die Verkleidung von Kaminen und Öfen bzw. die Verwendung in der Nähe von Wärmequellen wird nicht empfohlen. / Placas decoradas con innovadoras técnicas artesanales destinadas exclusivamente al revestimiento de paredes interiores. Toda posible pequeña imperfección ha de considerarse característica propia del producto debida al proceso de fabricación. Esta innovativa técnica decorativa mejora la definición y la profundidad de los colores, pero reduce la resistencia superficial al desgaste con respecto al gres porcelánico tradicional. Por este motivo hay que atenerse a las instrucciones que se encuentran en los embalajes (si no las hay, siempre pueden consultarse en el sitio web). El material también se puede utilizar para revestir la pared de la ducha. En el caso de este tipo de aplicación, para una correcta colocación, Florim recomienda instalar únicamente placas enteras o situar los recortes de placas donde no entren en contacto con el plato de la ducha. En caso de uso como salpicadero, Florim exige la colocación de las placas a una distancia mínima de 20 cm de los fogones de la superficie de cocción. Se desaconseja el empleo de este material para revestir chimeneas, estufas y, más en general, superficies cercanas a fuentes de calor.</p>
<p>MOVIMENTAZIONE HANDLING MANUTENTION TRANSPORT UND HANDHABUNG DESPLAZAMIENTO</p>	<p>Nella movimentazione evitare il contatto con materiali abrasivi e lo strofinamento con altre lastre o con il piano di lavoro. Non appoggiare sulla superficie utensili o altro materiale che potrebbe danneggiare il prodotto. Si consiglia di movimentare le lastre utilizzando appositi telai a ventosa, assicurandosi che le ventose siano perfettamente pulite e avendo cura di: -utilizzare ventose dotate di vacuometro per valutare/verificare la correttezza e costante adesione delle ventose stesse alla lastra (per movimentare lastre lucide è possibile mantenere la pellicola); - definire il numero di operatori addetti alla fase di movimentazione sulla base del peso totale (lastra più telaio) da sollevare e di eventuali limiti imposti da norme antinfortunistiche. - ridurre al minimo (pochi metri) il tragitto di movimentazione manuale con ventosa. / When handling, avoid contact with abrasive materials or rubbing against other slabs or the work surface. Do not place tools or any other material on the slab which might damage the surface or the product. It is recommended to use suction cups for moving the slabs, making sure that the suction cups are perfectly clean and always - using suction cups with vacuum meter, for measuring/checking correct, constant adhesion between the suction cups and the slab (when handling glossy slabs, the film can be left in place); - deciding the number of workers to be assigned to handling operations on the basis of the total weight (slab plus frame) to be lifted and any limits set by safety regulations; - minimising (to just a few metres) the distance over which slabs are carried by hand with suction cup. / Pendant la manutention, éviter tout contact avec des matériaux abrasifs et tout frottement avec d'autres dalles ou avec le plan de travail. Ne pas poser sur la surface des outils ou autre matériel susceptibles d'endommager le produit. Il est recommandé d'utiliser les araignées à ventouses pour manutentionner les dalles en s'assurant que les ventouses sont parfaitement propres et en veillant à: - utiliser des ventouses avec vacuomètre pour évaluer/vérifier la bonne adhérence des ventouses à la dalle (pour manutentionner des dalles brillantes, la pellicule peut être laissée); - définir le nombre d'opérateurs nécessaires à la manutention selon le poids total (dalle + araignée) à soulever et selon les éventuelles restrictions imposées par les normes relatives à la prévention des accidents. - réduire au minimum (quelques mètres) le parcours de manutention manuelle avec ventouse. / Bei der Handhabung sind Berührung mit scheuernden Materialien und der Reibecontact mit anderen Platten oder der Werkbank zu vermeiden. Werkzeuge oder anderweitige Gegenstände, die das Produkt beschädigen könnten, dürfen nicht auf der Oberfläche abgelegt werden. Es wird empfohlen, für das Tragen und Heben der Platten einen Heberahmen mit Saugtellern zu verwenden. Hierbei ist sicherzustellen, dass die Saugteller vollkommen sauber sind, und ist auf Folgendes zu achten: -Die Saugteller sollen mit einem Vakuummeter ausgestattet sein, um Ihre sichere und konstante Haftung an der Platte beurteilen/kontrollieren zu können (für das Handling von glänzenden Platten kann die Schutzfolie an Ort und Stelle verbleiben). - Die Anzahl der Mitarbeiter für das Handling auf der Grundlage des Gesamtgewichts (Platte plus Heberahmen) und etwaiger Sicherheitsvorgaben zum Unfallschutz bestimmen. - Der Transportweg für das manuelle Handling der Platte ist auf ein Mindestmaß (wenige Meter) zu reduzieren. / En el desplazamiento evitese el contacto con materiales abrasivos y el roce con otras placas o con la superficie de trabajo. No depositar sobre la superficie herramientas ni ningún material que pueda dañar el producto. Se aconseja desplazar las placas utilizando bastidores dotados de ventosas, cerciorándose previamente de que estas estén perfectamente limpias y procurando: - utilizar ventosas provistas de vacuómetro para evaluar/verificar la correcta y constante adherencia de las mismas a la placa (en caso de desplazar placas brillantes puede mantenerse la película de protección); - establecer el número de operarios que van a encargarse del desplazamiento en función del peso total (placa más bastidor) que haya de levantarse y de las posibles limitaciones que las normas de prevención de accidentes impongan; - reducir al mínimo (a unos pocos metros) el trayecto de desplazamiento manual con ventosa.</p>
<p>TAGLIO/FORO CUTTING/DRILLING DÉCOUPE/TROU SCHNEIDEN/BOHREN CORTE/ORIFICIO</p>	<p>Verificare che il piano di appoggio sia perfettamente stabile, piano, pulito e privo di ogni asperità che possa danneggiare il materiale; è possibile usare come protezione della superficie, quando necessario, il foglio "protettivo/distanziante" contenuto nell'imballo. Come tagliare le lastre delle diverse collezioni. Gold: incidere il retro della lastra utilizzando appositi strumenti a taglio per lastre avendo cura di rimuovere, prima del taglio, la pellicola protettiva, quando presente. (Check that the supporting surface is perfectly stable, flat and clean and does not have any rough areas which may damage the material. The "protective/spacer" sheet provided in the packaging can be used to protect the surface when necessary. How to cut slabs from the various collections: Gold: cut into the back of the slab using suitable slab cutting tools, taking care to remove any protective film before cutting. / S'assurer que la surface d'appui est parfaitement stable, plane, propre et sans irrégularités susceptibles d'endommager le produit. Il est possible d'utiliser la feuille de protection/d'espacement contenue dans l'emballage pour protéger la surface, si nécessaire. Comment découper les dalles des différentes collections: Gold: faire une amorce au dos de la dalle en utilisant les outils de coupe pour dalles en veillant à retirer, avant la coupe, l'éventuel film de protection. / Kontrollieren, dass die Arbeitsunterlage vollkommen stabil, plan und sauber ist und keine Unebenheiten aufweist, die zu Beschädigungen der Platte führen könnten. Für den Oberflächenschutz kann bei Bedarf die Schutzfolie an Ort und Stelle verbleiben. Die Anzahl der Mitarbeiter für das Handling auf der Grundlage des Gesamtgewichts (Platte plus Heberahmen) und etwaiger Sicherheitsvorgaben zum Unfallschutz bestimmen. - Der Transportweg für das manuelle Handling der Platte ist auf ein Mindestmaß (wenige Meter) zu reduzieren. / En el desplazamiento evitese el contacto con materiales abrasivos y el roce con otras placas o con la superficie de trabajo. No depositar sobre la superficie herramientas ni ningún material que pueda dañar el producto. Se aconseja desplazar las placas utilizando bastidores dotados de ventosas, cerciorándose previamente de que estas estén perfectamente limpias y procurando: - utilizar ventosas provistas de vacuómetro para evaluar/verificar la correcta y constante adherencia de las mismas a la placa (en caso de desplazar placas brillantes puede mantenerse la película de protección); - establecer el número de operarios que van a encargarse del desplazamiento en función del peso total (placa más bastidor) que haya de levantarse y de las posibles limitaciones que las normas de prevención de accidentes impongan; - reducir al mínimo (a unos pocos metros) el trayecto de desplazamiento manual con ventosa.</p>
<p>POSA INSTALLATION POSE VERLEGUNG COLOCACIÓN</p>	<p>Si sconsiglia l'uso di distanziatori livellanti tradizionali. E' possibile utilizzare i livellanti a vite dotati di guarnizione protettiva (che deve essere assolutamente pulita per evitare di rovinare/segare la lastra). / The use of standard levelling spacers is not recommended. Screw levelling spacers with protective gasket (which must be absolutely clean to avoid damaging the slab) may be used. / Il est déconseillé d'utiliser les croisillons nivélants traditionnels. Il est possible d'utiliser les croisillons à vis avec joint de protection (qui doit être absolument propre pour éviter d'abîmer/de marquer la dalle). / Die Verwendung von herkömmlichen Verlegehilfen wird nicht empfohlen. Es können Verlegehilfen mit Schraubsystem verwendet werden, die mit einer Schutzdichtung ausgestattet sind (diese muss vollkommen sauber sein, damit keine Beschädigungen/Kratzer an der Platte entstehen). / Se desaconseja el uso de separadores de nivelación tradicionales. Se pueden utilizar separadores de nivelación de tornillo dotados de guarnición de protección (que ha de estar perfectamente limpia para evitar estropear/arañar la placa).</p>
<p>STUCCATURA GROUTING RÉALISATION DES JOINTS VERFUGEN REJUNTADO</p>	<p>Si consiglia l'uso di soli sigillanti cementizi a grana fine e spatole in materiale plastico. Si sconsiglia l'uso di silicone acetico come sigillante. (Attenzione: la pellicola, quando presente, non deve impedire il corretto e completo riempimento della fuga). Proteggere con scotch di carta la superficie prima della sigillatura. Gold Lucido: applicare il sigillante con spatola di gomma mantenendo la pellicola sulle lastre intere. Per le lastre che sono state tagliate e che quindi non hanno la pellicola, utilizzare scotch di carta sui perimetri e successivamente applicare il sigillante con spatola di gomma. / Only fine-grain cement grouts and plastic trowels should be used. The use of acetoxy silicone as a grout is not recommended. (Important: any film present must not prevent correct, complete filling of the joint). Protect the surface with masking tape before grouting Glossy Gold: apply the grout with a rubber trowel, keeping the film over the whole slabs. On cut slabs which no longer have the film in place, use masking tape around the edges and then apply the grout with a rubber trowel. / I est recommandé d'utiliser uniquement des mortiers-ciments à grains fins et des spatules en plastique. Il est déconseillé d'utiliser un silicone acétique pour l'exécution des joints. (Attention: le film de protection, si présent, ne doit pas entraver le remplissage complet du joint). Avant de faire les joints, protéger la surface avec un ruban papier adhésif. Gold brillante: appliquer le mortier avec une spatule en caoutchouc en gardant le film de protection sur les dalles entières. Pour les dalles découpées et donc dépourvues du film de protection, mettre un ruban papier adhésif sur les bords, puis appliquer le mortier avec une spatule en caoutchouc. / Für die Verfugung empfehlen wir, ausschließlich feinkörnigen zementären Fugenmörtel und einen Gummischieber zu verwenden. Die Verwendung von Acetatsilikon wird nicht empfohlen. (Achtung: Sofern vorhanden, darf die Schutzfolie nicht die korrekte und vollständige Ausfüllung der Fuge behindern). Die Plattenoberfläche vor dem Verfugen mit Papierklebeband abkleben. Gold glänzend:Fugenmörtel mit Gummischieber auftragen und Schutzfolie auf der ganzen Platte belassen. Bei zugeschnittenen Platten ohne Schutzfolie ist der Randbereich mit Papierklebeband abzukleben und anschließend der Fugenmörtel mit Gummischieber aufzutragen. / Se recomienda emplear exclusivamente selladores cementosos de grano fino y espátulas de plástico. Se desaconseja el uso de silicona acética para sellar. /OJO! La película de protección, cuando la haya, no debe impedir el correcto y completo llenado de las juntas. Antes de sellar protéjase la superficie con cinta de papel. Gold brillante: aplicar el sellador con una espátula de goma sin quitar la película de las placas enteras. En el caso de las placas que se han cortado y que por consiguiente ya no tienen la película de protección, aplicar cinta adhesiva de papel a lo largo de los perímetros y a continuación aplicar el sellador con la espátula de goma.</p>
<p>PULIZIA POST POSA POST-INSTALLATION CLEANING NETTOYAGE APRES POSE ERSTREINIGUNG LIMPIEZA TRAS LA COLOCACIÓN</p>	<p>Avere cura di pulire i residui prima dell'indurimento dello stucco con acqua e spugna non abrasiva evitando di danneggiare la superficie della lastra. / Clean away residues thoroughly before the grout sets using water and a non-abrasive sponge, taking care not to damage the surface of the slab. / Avant le durcissement du mortier, prendre soin d'éliminer les résidus avec de l'eau et une éponge non abrasive, en évitant d'endommager la surface de la dalle. / Rückstände sind vor der Aushärtung mit Wasser und einem weichen Schwamm abzuwaschen, wobei darauf zu achten ist, dass die Oberfläche nicht beschädigt wird. / Antes de que se endurezcan, limpie los restos de rejunte con agua y una esponja no abrasiva procurando no estropear la superficie de la placa.</p>
<p>PULIZIA QUOTIDIANA DAILY MAINTENANCE ENTRETIEN QUOTIDIEN UNTERHALTSREINIGUNG LIMPIEZA COTIDIANA</p>	<p>Utilizzare detergenti neutri e/o acqua, pulendo con straccio in microfibra o spugna morbida. Prodotti acidi anticalcareo possono essere utilizzati avendo cura di risciacquare rapidamente la superficie con acqua dopo l'applicazione. Non utilizzare solventi (alcol e simili) né spugne abrasive. / Use neutral detergents and/or water, cleaning with a microfibre cloth or soft sponge. Acid limescale remover products may be used, but take care to rinse the surface with water quickly after application. Do not use solvents (alcohols and similar substances) or abrasive sponges. / Laver avec des détergents neutres et/ou de l'eau, avec un chiffon microfibre ou une éponge douce. Les produits acides anticalcars peuvent être utilisés à condition de rincer rapidement la surface à l'eau après application. Ne pas utiliser de solvants (alcools et similaires) ni d'éponges abrasives. / Neutrale Reinigungsmittel und/oder Wasser sowie ein Mikrofasertuch oder einen weichen Schwamm verwenden. Bei Verwendung von säurehaltigen Kalkentferner ist die Oberfläche unverzüglich mit Wasser nachzuspülen. Keine Lösemittel (Alkohol o.ä.) und Scheuerschwämme verwenden. / Utilizar detergentes neutros y/o agua y limpiar con trapos de microfibra o esponjas suaves. Se pueden utilizar productos/ácidos anticálculo siempre y cuando, tras su aplicación, se aclare de inmediato la superficie con agua. Evitese el uso de esponjas abrasivas y de disolventes (como alcohol o similares).</p>

Lastre decorate destinate esclusivamente al rivestimento di pareti interne. / Decorated panels designed exclusively for tiling interior walls. / Dalles décorées, exclusivement destinées au revêtement de parois intérieures. Verzierte Platten, ausschließlich zur Verkleidung von Innenwänden bestimmt. / Losas decoradas destinadas exclusivamente al revestimiento de paredes interiores.

Gres porcellanato decorato: florim indica di stoccare il materiale in magazzini coperti o al riparo da agenti atmosferici / Florim recommends to stock the goods in covered warehouses, do not expose to the elements Florim conseille de stocker le matériel dans des entrepôts couverts ou à l'abri des agents atmosphériques / Florim empfiehlt, das Material in geschlossenen Lagern oder in vor Witterungseinflüssen geschützten Bereichen zu lagern. / Florim indica almacenar el material en locales cubiertos o protegido de los agentes atmosféricos.



HERITAGE LUXE

gres fine porcellanato
fine porcelain stoneware
grès cérame fin
feinsteinzeug-kollektionen
gres porcelánico fino



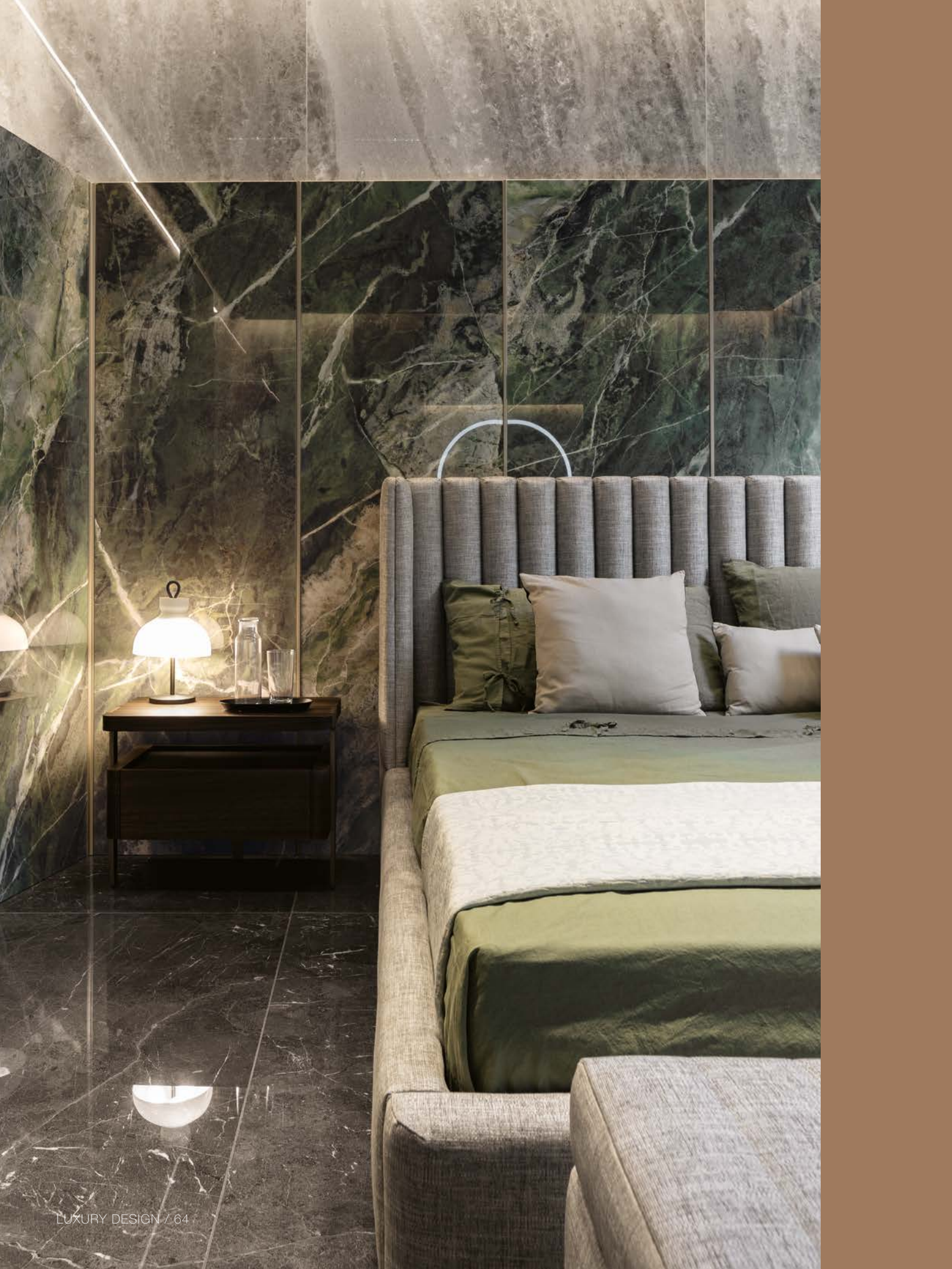

HERITAGE LUXE

Ispirata alle nobili cromie e alle maestose venature del marmo, la collezione **Heritage Luxe** ci accompagna in un immaginario viaggio alla riscoperta di un patrimonio artistico e architettonico di inestimabile valore culturale che oggi abbiamo il privilegio di ereditare. Sin dall'antichità, infatti, palazzi, sculture e monumenti del vecchio continente sono stati realizzati utilizzando marmi colorati, considerati quasi come una forma di pittura naturale o divina, grazie alle venature vivaci e alla tavolozza variopinta. Le superfici della collezione, in linea con i tempi moderni, presentano uno spiccato carattere decorativo e atualizzano l'Heritage della tradizione europea proponendo un concept stilistico ispirato alla bellezza e al lusso classico del marmo che si fonde al dinamismo di venature e cromie dal sapore contemporaneo.

Taking inspiration from the noble hues and majestic veining of marble, the **Heritage Luxe** collection accompanies us on an imaginary journey to rediscover an artistic and architectural heritage of inestimable cultural value that we are now privileged to inherit. Since ancient times, palaces, sculptures and monuments in Europe have been created from colored marble, considered almost like a form of natural or divine painting thanks to its vivid veining and varied color palette. In keeping with modern times, the surfaces of the collection have a strong decorative character and bring the heritage of the European tradition up to date by proposing a stylistic concept inspired by the beauty and classic luxury of marble that blends with the dynamism of veining and colors of a contemporary flavor.

Inspirée des couleurs nobles et des veines majestueuses du marbre, la collection **Heritage Luxe** nous accompagne dans un voyage imaginaire à la redécouverte d'un patrimoine artistique et architectural à la valeur culturelle inestimable que nous avons aujourd'hui le privilège d'hériter. En effet, dès l'Antiquité, les palais, les sculptures et les monuments du Vieux Continent ont été réalisés à l'aide de marbres colorés, considérés quasiment comme une forme de peinture naturelle ou divine, grâce aux veines vives et à la palette aux nuances multiples. Les surfaces de la collection, en ligne avec les temps modernes, présentent un caractère décoratif marqué et mettent au goût du jour l'Héritage de la tradition européenne : elles offrent un concept stylistique inspiré de la beauté et du luxe classique du marbre, qui se fond dans le dynamisme des veines et des couleurs à l'esprit contemporain.

Von den edlen Farben und majestätischen Adern des Marmors inspiriert, nimmt uns die Kollektion **Heritage Luxe** mit auf eine imaginäre Reise, um ein künstlerisches und architektonisches Erbe von unschätzbarem kulturellem Wert wiederzuentdecken, das wir heute zu erben das Privileg haben. Tatsächlich wurden seit der Antike Paläste, Skulpturen und Denkmäler des alten Kontinents aus farbigem Marmor gefertigt, der dank der lebhaften Adern und der farbenfrohen Palette fast als eine Form natürlicher oder göttlicher Malerei angesehen wurde. Die Oberflächen der Kollektion haben im Einklang mit der Moderne einen unverkennbar dekorativen Charakter und aktualisieren das Erbe der europäischen Tradition, indem sie ein stilistisches Konzept vorschlagen, das von der Schönheit und dem klassischen Luxus des Marmors inspiriert ist, der sich mit der Dynamik von Adern und Farben von zeitgemäßem Geschmack verbindet.

Inspirada en los tonos nobles y en las majestuosas vetas del mármol, la colección **Heritage Luxe** nos acompaña en un viaje imaginario para redescubrir un patrimonio artístico y arquitectónico de inestimable valor cultural que hoy tenemos el privilegio de heredar. De hecho, desde la antigüedad, los palacios, esculturas y monumentos del viejo continente se han realizado utilizando mármoles de colores, considerados casi como una forma de pintura natural o divina, gracias a las animadas vetas y a su variopinta paleta de colores. Las superficies de la colección, en consonancia con las tendencias modernas, presentan un marcado carácter decorativo y actualizan la herencia de la tradición europea proponiendo un concepto estilístico inspirado en la belleza y en el lujo clásico del mármol, que se funde con el dinamismo de vetas y colores con sabor contemporáneo.

HERITAGE LUXE

HERITAGE CLOUD



HERITAGE AZURE



V2
HERITAGE
CLOUD

V3
HERITAGE
AZURE

R10
(comfort)

CLASSE B
(comfort)

DCOF >
0,42 Wet
(comfort)

BS EN 16165
ANNEX C
>36 wet
slider 4S
(comfort)

9 mm 3/8" ↑↓

V2
HERITAGE
CLOUD

V3
HERITAGE
AZURE

R10
(comfort)

CLASSE B
(comfort)

DCOF >
0,42 Wet
(comfort)





BS EN 16165
ANNEX C
>36 wet
slider 4S
(comfort)

6 mm 1/4" ↑↓

FLORIM OVERSIZE
magnUm

GRES FINE PORCELLANATO

FINE PORCELAIN STONEWARE/GRES CERAME FIN/FEINSTEINZEUG-KOLLEKTIONEN/GRES PORCELANICO FINO
SQUADRATO - SQUARED - EQUARRI - REKTIFIZIERT - ESCUADRADO

		9 mm 3/8" ↑↓		80x180 31 1/2" x 70 6/7"		60x120 23 5/8" x 47 1/4"					
		COLOR	SURFACE								
HERITAGE LUXE		HERITAGE CLOUD	GLOSSY	774598 ■ FL-11900	775049 ■ FL-11300						
			COMFORT	774589 ■ FL-10500	775043 ■ FL-09900						
		HERITAGE AZURE	GLOSSY	774595 ■ FL-11900	775048 ■ FL-11300						
			COMFORT	774588 ■ FL-10500	775042 ■ FL-09900						
		6 mm 1/4" ↑↓		120x280 47 1/4" x 110 1/4"		120x240 47 1/4" x 94 1/2"		120x120 47 1/4" x 47 1/4"		60x120 23 5/8" x 47 1/4"	
		COLOR	SURFACE								
HERITAGE LUXE		HERITAGE CLOUD	GLOSSY	774696 ■ FL-15100	774826 ■ FL-14000	774838 ■ FL-12400	774850 ■ FL-11300				
			COMFORT	774695 ■ FL-12400	774820 ■ FL-11300	774832 ■ FL-09700	774844 ■ FL-09100				
		HERITAGE AZURE	GLOSSY	774694 ■ FL-15100	774825 ■ FL-14000	774837 ■ FL-12400	774849 ■ FL-11300				
			COMFORT	774693 ■ FL-12400	774819 ■ FL-11300	774831 ■ FL-09700	774843 ■ FL-09100				

HERITAGE BROWN



HERITAGE EMERALD



R10
(comfort)

CLASSE B
(comfort)

DCOF>
0,42 Wet
(comfort)

BS EN 16165
ANNEX C
>36 wet
slider 4S
(comfort)

9 mm 3/8" ↑↓



R10
(comfort)

CLASSE B
(comfort)

DCOF>
0,42 Wet
(comfort)



BS EN 16165
ANNEX C
>36 wet
slider 4S
(comfort)

6 mm 1/4" ↑↓

FLORIM OVERSIZE
magnum

GRES FINE PORCELLANATO
FINE PORCELAIN STONEWARE/GRES CERAME FIN/FEINSTEINZEUG-KOLLEKTIONEN/GRES PORCELANICO FINO
SQUADRATO - SQUARED - EQUARRI - REKTIFIZIERT - ESCUADRADO

		COLOR	SURFACE	80x180 31 1/2" x 70 5/7"	60x120 23 5/8" x 47 1/4"
HERITAGE LUXE		HERITAGE BROWN	GLOSSY	774599 ■ FL-11900	775050 ■ FL-11300
			COMFORT	774590 ■ FL-10500	775044 ■ FL-09900
		HERITAGE EMERALD	GLOSSY	774600 ■ FL-11900	775051 ■ FL-11300
			COMFORT	774591 ■ FL-10500	775045 ■ FL-09900

		COLOR	SURFACE	120x280 47 1/4" x 110 1/4"	120x240 47 1/4" x 94 1/2"	120x120 47 1/4" x 47 1/4"	60x120 23 5/8" x 47 1/4"
HERITAGE LUXE		HERITAGE BROWN	GLOSSY	774698 ■ FL-15100	774827 ■ FL-14000	774839 ■ FL-12400	774851 ■ FL-11300
			COMFORT	774697 ■ FL-12400	774821 ■ FL-11300	774833 ■ FL-09700	774845 ■ FL-09100
		HERITAGE EMERALD	GLOSSY	774700 ■ FL-15100	774828 ■ FL-14000	774840 ■ FL-12400	774852 ■ FL-11300
			COMFORT	774699 ■ FL-12400	774822 ■ FL-11300	774834 ■ FL-09700	774846 ■ FL-09100

HERITAGE LUXE

HERITAGE AQUA



HERITAGE FLAME

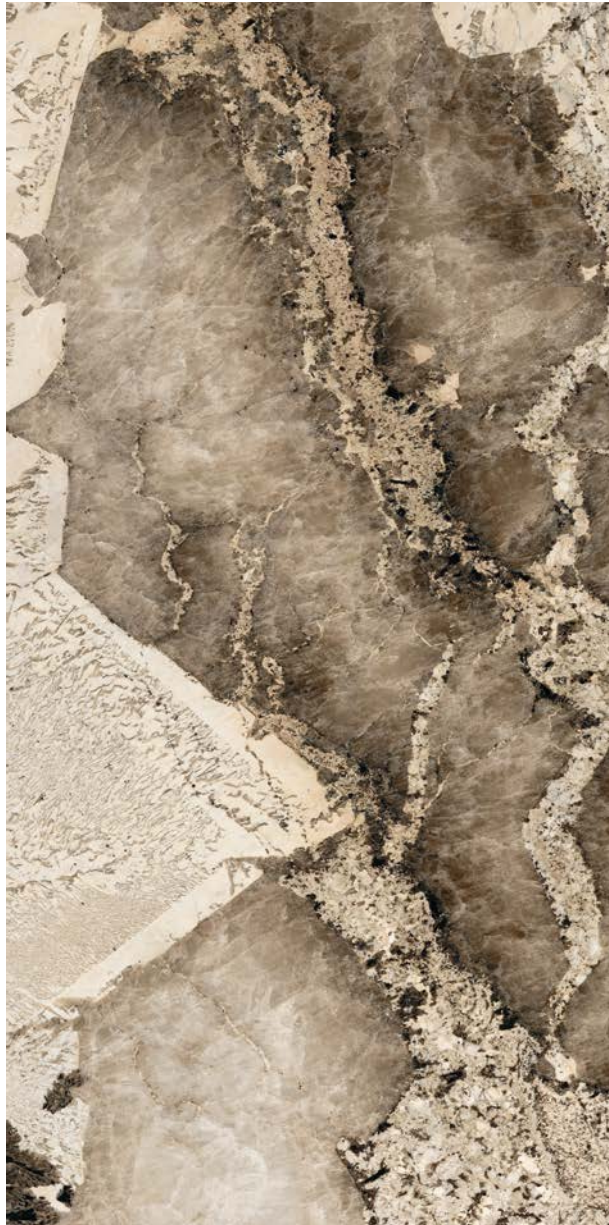

V4
R10
(comfort)

CLASSE B
(comfort)

DCOF>
0,42 Wet
(comfort)

BS EN 16165
ANNEX C
>36 wet
slider 4S
(comfort)

9 mm 3/8" ↑↓



V4
R10
(comfort)

CLASSE B
(comfort)

DCOF>
0,42 Wet
(comfort)





BS EN 16165
ANNEX C
>36 wet
slider 4S
(comfort)

6 mm 1/4" ↑↓









FLORIM OVERSIZE
magnum







GRES FINE PORCELLANATO

FINE PORCELAIN STONEWARE/GRES CERAME FIN/FEINSTEINZEUG-KOLLEKTIONEN/GRES PORCELANICO FINO
SQUADRATO - SQUARED - EQUARRI - REKTIFIZIERT - ESCUADRADO

		9 mm 3/8" ↑↓		80x180 31 1/2" x 70 6/7"		60x120 23 5/8" x 47 1/4"					
		COLOR	SURFACE								
HERITAGE LUXE		HERITAGE AQUA	GLOSSY	774601 ■ FL-11900	775053 ■ FL-11300						
			COMFORT	774592 ■ FL-10500	775046 ■ FL-09900						
		HERITAGE FLAME	GLOSSY	774602 ■ FL-11900	775054 ■ FL-11300						
			COMFORT	774593 ■ FL-10500	775047 ■ FL-09900						
		6 mm 1/4" ↑↓		120x280 47 1/4" x 110 1/4"		120x240 47 1/4" x 94 1/2"		120x120 47 1/4" x 47 1/4"		60x120 23 5/8" x 47 1/4"	
		COLOR	SURFACE								
HERITAGE LUXE		HERITAGE AQUA	GLOSSY	774702 ■ FL-15100	774829 ■ FL-14000	774841 ■ FL-12400	774856 ■ FL-11300				
			COMFORT	774701 ■ FL-12400	774823 ■ FL-11300	774835 ■ FL-09700	774847 ■ FL-09100				
		HERITAGE FLAME	GLOSSY	774704 ■ FL-15100	774830 ■ FL-14000	774842 ■ FL-12400	774858 ■ FL-11300				
			COMFORT	774703 ■ FL-12400	774824 ■ FL-11300	774836 ■ FL-09700	774848 ■ FL-09100				

PEZZI SPECIALI/SPECIAL TRIMS/PIÈCES SPÉCIALES/FORMSTÜCKE/PIEZAS ESPECIALES

9 mm 3/8" ↑		COLOR	SURFACE	4,6x60 1 4/5" x 2 3/8"	33x120x3 13" x 47 1/4" x 1 1/8"
				 battiscopa	 gradino pz/box 2
HERITAGE LUXE		HERITAGE AZURE	GLOSSY	775667 ◆ FL-01600	775679 ▲ FL-22600
		HERITAGE AZURE	COMFORT	775661 ◆ FL-01600	775673 ▲ FL-20400
		HERITAGE CLOUD	GLOSSY	775668 ◆ FL-01600	775680 ▲ FL-22600
		HERITAGE CLOUD	COMFORT	775662 ◆ FL-01600	775674 ▲ FL-20400
		HERITAGE BROWN	GLOSSY	775670 ◆ FL-01600	775682 ▲ FL-22600
		HERITAGE BROWN	COMFORT	775664 ◆ FL-01600	775676 ▲ FL-20400
		HERITAGE EMERALD	GLOSSY	775669 ◆ FL-01600	775681 ▲ FL-22600
		HERITAGE EMERALD	COMFORT	775663 ◆ FL-01600	775675 ▲ FL-20400
		HERITAGE AQUA	GLOSSY	775672 ◆ FL-01600	775684 ▲ FL-22600
		HERITAGE AQUA	COMFORT	775666 ◆ FL-01600	775678 ▲ FL-20400
		HERITAGE FLAME	GLOSSY	775671 ◆ FL-01600	775683 ▲ FL-22600
		HERITAGE FLAME	COMFORT	775665 ◆ FL-01600	775677 ▲ FL-20400

6 mm 1/4" ↑		COLOR	SURFACE	4,6x60 1 4/5" x 2 3/8"
				 battiscopa
HERITAGE LUXE		HERITAGE AZURE	GLOSSY	775691 ◆ FL-01800
		HERITAGE AZURE	COMFORT	775685 ◆ FL-01800
		HERITAGE CLOUD	GLOSSY	775692 ◆ FL-01800
		HERITAGE CLOUD	COMFORT	775686 ◆ FL-01800
		HERITAGE BROWN	GLOSSY	775694 ◆ FL-01800
		HERITAGE BROWN	COMFORT	775688 ◆ FL-01800
		HERITAGE EMERALD	GLOSSY	775693 ◆ FL-01800
		HERITAGE EMERALD	COMFORT	775687 ◆ FL-01800
		HERITAGE AQUA	GLOSSY	775696 ◆ FL-01800
		HERITAGE AQUA	COMFORT	775690 ◆ FL-01800
		HERITAGE FLAME	GLOSSY	775695 ◆ FL-01800
		HERITAGE FLAME	COMFORT	775689 ◆ FL-01800



HERITAGE LUXE

6 mm 1/4" ↑↓

COLOR

SURFACE

30x60
11^{4/5"}x23^{5/8"}
PICKET

HERITAGE LUXE



Heritage cloud+
Heritage emerald

GLOSSY

775657
▲ FL-04850

6 mm 1/4" ↑↓

COLOR

SURFACE

39x49
15^{1/2"}x19^{2/3"}
MAZE

HERITAGE LUXE



Heritage brown+
Heritage emerald+
Heritage flame

GLOSSY

775659
▲ FL-07600

6 mm 1/4" ↑↓

COLOR

SURFACE

30x60
11^{4/5"}x23^{5/8"}
TRINITY

HERITAGE LUXE

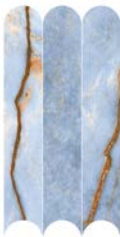

Heritage azure

GLOSSY

775658
▲ FL-04850

FLORIM OVERSIZE
magnlum

120x280/120x240/120x120/60x120

Specifica Imballo pag.
Packaging specifications on page
Spécifications d'emballage à page
Verpackungsdetail Seite
Especificaciones de embalaje a la página
204/205

In relazione alle differenti tecnologie produttive l'accostamento di prodotti con spessori diversi potrebbe presentare delle disomogeneità, se ne sconsiglia pertanto l'abbinamento. / Due to the different production technologies, contiguous installation of products with different thickness may give a non-homogeneous result. For this reason we do not recommend this option. / Vu que différentes technologies de production sont utilisées avec des épaisseurs différentes, des problèmes d'homogénéité pourraient se présenter, il est donc déconseillé de les poser ensemble. / Wegen unterschiedlicher Produktionstechnologien können die Fliesen mit verschiedenen Materialstärken optische Differenzen aufweisen. Von einem direkten Aneinanderlegen wird deshalb abgeraten. / Dadas las diferentes tecnologías productivas, la combinación de productos de diferentes espesores podría dar lugar a heterogeneidad, por lo que se desaconseja mezclarlas.

Per un effetto ottimale della posa, florim suggerisce di mantenere 2 mm di fuga per pose monofornato e 3 mm per combinare formati misti. - For optimal installation results, florim recommends maintaining a joint of 2 mm 1/12" for single format installations and 3 mm 1/8" to combine mixed formats. - Pour réaliser une pose parfaite, florim suggère de maintenir 2 mm de joint pour la pose des monofornats, et 3 mm pour les combinaisons de formats mixtes. - Um einen optimalen effekt beim verlegen zu erzielen empfiehlt florim eine 2 mm fuger bei einformatigen verlegungen und 3 mm fuger bei formatkombinationen. Para lograr los máximos resultados en la posa del producto, florim aconseja 2 mm de junta en aplicaciones monofornato y 3 mm en combinaciones de formatos mixtos.

HERITAGE LUXE	scatola - box			pallet		
	pz	mq	kg	box	mq	kg
80x180	2	2,88	57,60	20	57,60	1210
60x120	2	1,44	27,73	30	43,20	860

HERITAGE LUXE	scatola - box			pallet		
	pz	ml	kg	box	mq	kg
4,6x60 battiscopa	14	8,40	8,40	-	-	-

Luxury design





I CLASSICI

gres porcellanato colorato in massa
coloured body porcelain stoneware
grès cérame colore dans la masse
durchgefärbte feinsteinzeug
gres porcelánico coloreado en masa

decò wood:

gres fine porcellanato
fine porcelain stoneware
grès cérame fin
feinsteinzeug-kollektionen
gres porcelánico fino





I CLASSICI

Il prezioso contenitore de **I Classici** si arricchisce di nuovi suggestivi prodotti: 4 marmi ricercati che riportano alla mente eleganti atmosfere anni cinquanta tradotte in una fresca e inattesa modernità. Ingredienti perfetti per un progetto tailor made che traccia una nuova linea di lusso racchiuso nelle linee eleganti e fluide e nei contrasti di chiaro scuro. Un forte carattere estetico permette di creare uno spazio architettonico con un approccio personale e libero da vincoli predefiniti per la realizzazione di un luogo autentico e del tutto affine al proprio immaginario dell'abitare. Una vibrante energia si riflette dal prodotto al progetto portando con sé contemporaneamente la nostalgia del passato e l'innovazione del futuro.

The valuable container of **I Classici** is further enriched with suggestive products: 4 sought-after marbles bringing to mind the elegant atmosphere of the fifties, interpreted with a fresh and unexpected modern accent. Perfect ingredients for a tailor-made project, which draws a new line of luxury, enveloped in sleek, flowing lines and chiaroscuro contrasts. A strong aesthetic character for us to create architectural areas, using an approach which is personal and free of pre-defined constraints, designing authentic settings, fully in tune with our personal concepts of living. Vibrant energy reflects from the product to the project, bringing with it both nostalgia for the past and innovation for the future.

La précieuse collection « **I Classici** » s'enrichit de nouveaux produits de charme: 4 marbres raffinés qui évoquent les atmosphères élégantes des années '50, revisitées au goût du jour dans un style frais et surprenant. Des ingrédients parfaits pour un projet sur mesure, traçant une nouvelle ligne de luxe, qui s'exprime dans les lignes élégantes et fluides ainsi que dans les contrastes de clair-obscur. Un fort caractère esthétique permet de créer un espace architectural avec une approche personnelle et libre de contraintes pour la réalisation d'un lieu authentique et s'inscrivant parfaitement dans l'imaginaire individuel de l'habiter. Une énergie vibrante se reflète du produit au projet, mêlant nostalgie du passé et innovation du futur.

Die kostbare Kollektion "**I Classici**" wird um neue, bezaubernde Produkte erweitert: 4 edle Marmorvarianten, die an die elegante Atmosphäre der 50er Jahre erinnern und zugleich auf frische, unerwartet moderne Art und Weise interpretiert wurden. Perfekte Elemente für ein maßgeschneidertes Projekt, das eine neue, durch elegante, fließende Linien und Hell-Dunkel-Kontraste gekennzeichnete Vorstellung von Luxus einführt. Dem starken ästhetischen Charakter ist es zu verdanken, dass ein individueller architektonischer Raum ohne festgelegte Vorgaben entsteht, in dem sich ein authentischer Ort realisieren lässt, der voll und ganz der eigenen Wohnvorstellung entspricht. Eine vibrierende Energie überträgt sich vom Produkt auf das Projekt und bringt gleichzeitig Sehnsucht nach der Vergangenheit und die Innovation der Zukunft mit sich.

La preciosa colección de **I Classici** se enriquece con nuevos y sugerentes productos: 4 mármoles refinados que nos traen a la mente elegantes atmósferas de los años cincuenta traducidas a una fresca e inesperada modernidad. Ingredientes perfectos para un proyecto tailor made que traza una nueva línea de lujo comprendido en las líneas elegantes y fluidas y en los contrastes de claroscuro. Un fuerte carácter estético permite crear un espacio arquitectónico con un planteamiento personal y libre de vínculos predefinidos para la realización de un lugar auténtico y completamente afín al propio imaginario del hogar. Una vibrante energía se refleja del producto al proyecto, llevando consigo al mismo tiempo la nostalgia del pasado y la innovación del futuro.

I CLASSICI

STATUARIO



CALACATTA GOLD

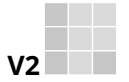

V2
DCOF>
0,42 Wet
(matte/soft)

9 mm 3/8" ↑↓

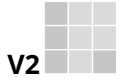

V2
DCOF>
0,42 Wet
(matte/soft)

6 mm 1/4" ↑↓

FLORIM OVERSIZE
magnum

GRES PORCELLANATO COLORATO IN MASSA/COLOURED BODY PORCELAIN STONEWARE
GRÈS CÉRAMÉ COLORE DANS LA MASSE/DURCHGEFÄRBTE FEINSTEINZEUG/GRES PORCELÁNICO COLOREADO EN MASA
SQUADRATO - SQUARED - EQUARRI - REKTIFIZIERT - ESCUADRADO

		9 mm 3/8" ↑↓		80x80 31 1/2" x 31 1/2"		60x120 23 5/8" x 47 1/4"		60x60 23 5/8" x 23 5/8"		30x60 11 4/5" x 23 5/8"	
		COLOR	SURFACE								
I CLASSICI		STATUARIO	GLOSSY	746591 ■ FL-11300	746592 ■ FL-12400	746590 ■ FL-11300	754467 ■ FL-07700				
			SOFT	746587 ■ FL-09700	746588 ■ FL-10800	746585 ■ FL-09300	754466 ■ FL-07000				
		CALACATTA GOLD	GLOSSY	750715 ■ FL-11300	750714 ■ FL-11900	750719 ■ FL-09700	754469 ■ FL-07700				
			MATTE	753297 ■ FL-09700	753296 ■ FL-10500	753298 ■ FL-08100	754468 ■ FL-06400				

		6 mm 1/4" ↑↓		160x320 63" x 126"		120x280 47 1/4" x 110"		160x160 63" x 63"		120x240 47 1/4" x 94 1/2"		80x240 31 1/2" x 94 1/2"		120x120 47 1/4" x 47 1/4"		80x80 31 1/2" x 31 1/2"		60x120 23 5/8" x 47 1/4"	
		COLOR	SURFACE																
I CLASSICI		STATUARIO	GLOSSY	746607 ■ FL-18800	757833 ■ FL-15100	746606 ■ FL-16100	746605 ■ FL-14000	746603 ■ FL-13400	746604 ■ FL-12400	746601 ■ FL-10300	746602 ■ FL-11300								
			SOFT	746600 ■ FL-15600	757832 ■ FL-12400	746599 ■ FL-13400	746598 ■ FL-11300	746596 ■ FL-10300	746597 ■ FL-09700	746594 ■ FL-08400	746595 ■ FL-09100								
		CALACATTA GOLD	GLOSSY	750673 ■ FL-18800	757835 ■ FL-15100	750701 ■ FL-16100	750682 ■ FL-14000	750683 ■ FL-13400	750702 ■ FL-12400	750704 ■ FL-10300	750703 ■ FL-11300								
			MATTE	753282 ■ FL-15600	757834 ■ FL-12400	753291 ■ FL-13400	753280 ■ FL-11300	753281 ■ FL-10300	753292 ■ FL-09700	753294 ■ FL-08400	753293 ■ FL-09100								

MARQUINIA



BRAZILIAN



V2
MARQUINIA

DCOF>
0,42 Wet
(matte)



V3
BRAZILIAN

9 mm 3/8" ↑↓

V2

6 mm 1/4" ↑↓
FLOHM OVERSIZE
magnUm

GRES PORCELLANATO COLORATO IN MASSA/COLOURED BODY PORCELAIN STONEWARE
GRÈS CÉRAME COLORE DANS LA MASSE/DURCHGEFÄRBTE FEINSTEINZEUG/GRES PORCELÁNICO COLOREADO EN MASA
SQUADRATO - SQUARED - EQUARRI - REKTIFIZIERT - ESCUADRADO

				9 mm 3/8" ↑↓		80x180 31 1/2" x 70 5/7"		80x80 31 1/2" x 31 1/2"		60x120 23 5/8" x 47 1/4"		60x60 23 5/8" x 23 5/8"		30x60 11 4/5" x 23 5/8"	
		COLOR	SURFACE												
I CLASSICI		MARQUINIA	GLOSSY	750874 ■ FL-13400	750877 ■ FL-11300	750876 ■ FL-11900	750878 ■ FL-09700	754471 ■ FL-07700							
			MATTE	751912 ■ FL-11300	751915 ■ FL-09700	751914 ■ FL-10500	751916 ■ FL-08100	754470 ■ FL-06400							
		BRAZILIAN	GLOSSY	750898 ■ FL-13400	750901 ■ FL-11300	750900 ■ FL-11900	755469 ■ FL-09700	754472 ■ FL-07700							

				6 mm 1/4" ↑↓		160x320 63" x 126"		160x160 63" x 63"		120x240 47 1/4" x 94 1/2"		120x120 47 1/4" x 47 1/4"		80x80 31 1/2" x 31 1/2"		60x120 23 5/8" x 47 1/4"	
		COLOR	SURFACE														
I CLASSICI		MARQUINIA	GLOSSY	750776 ■ FL-18800	750886 ■ FL-16100	750885 ■ FL-14000	750884 ■ FL-12400	757839 ■ FL-10300	750883 ■ FL-11300								
			MATTE	751942 ■ FL-15600	751924 ■ FL-13400	751923 ■ FL-11300	751922 ■ FL-09700	757838 ■ FL-08400	751921 ■ FL-09100								

I CLASSICI

PORTORO



V3

9 mm 3/8" ↑↓

GRES PORCELLANATO COLORATO IN MASSA/COLOURED BODY PORCELAIN STONWARE
 GRÈS CÉRAMÉ COLORE DANS LA MASSE/DURCHGEFÄRBTE FEINSTEINZEUG/GRES PORCELÁNICO COLOREADO EN MASA
 SQUADRATO - SQUARED - EQUARRI - REKTIFIZIERT - ESCUADRADO

9 mm 3/8" ↑↓	COLOR	SURFACE	80x180 31 ^{1/2"} x70 ^{6/7"}	80x80 31 ^{1/2"} x31 ^{1/2"}	60x120 23 ^{5/8"} x47 ^{1/4"}	60x60 23 ^{5/8"} x23 ^{5/8"}	30x60 11 ^{4/5"} x23 ^{5/8"}
I CLASSICI	PORTORO	GLOSSY	750912 ■ FL-13400	750915 ■ FL-11300	750914 ■ FL-11900	755470 ■ FL-09700	754473 ■ FL-07700

DECÒ WOOD WHITE





DECÒ WOOD PEARL



V3
R9
CLASSE A
DCOF >
0,42 Wet

9 mm 3/8" ↑↓

GRES FINE PORCELLANATO/FINE PORCELAIN STONEWARE
GRES CERAME FIN/FEINSTEINZEUG-KOLLEKTIONEN/GRES PORCELANICO FINO
SQUADRATO - SQUARED - EQUARRI - REKTIFIZIERT - ESCUADRADO

9 mm 3/8" ↑↓		COLOR	SURFACE	20x120 7 7/8" x 4 7/8"	15x120 6" x 4 7/8"
I CLASSICI		DECÒ WOOD WHITE	MATTE	748508 ■ FL-09300	748511 ■ FL-09300
		DECÒ WOOD PEARL	MATTE	748509 ■ FL-09300	748512 ■ FL-09300

I CLASSICI

DECÒ WOOD BLACK



V3

R9
CLASSE A

DCOF>
0,42 Wet

9 mm 3/8" ↑↓

GRES FINE PORCELLANATO/FINE PORCELAIN STONEWARE
GRES CERAME FIN/FEINSTEINZEUG-KOLLEKTIONEN/GRES PORCELANICO FINO
SQUADRATO - SQUARED - EQUARRI - REKTIFIZIERT - ESCUADRADO

9 mm 3/8" ↑↓	COLOR	SURFACE	20x120 7 7/8" x 4 7/8"	15x120 6" x 4 7/8"
	I CLASSICI 	DECÒ WOOD BLACK	MATTE	748510 ■ FL-09300

I CLASSICI DECÒ WOOD	scatola - box			pallet		
	pz	mq	kg	box	mq	kg
20x120	6	1,44	28,08	24	34,56	700
15x120	6	1,08	23,98	32	34,56	800

Luxury design



I CLASSICI

STATUARIO

OPEN BOOK SOFT A+B 320x320 (126"x126") (9000160) ■ FL-15600

OPEN BOOK GLOSSY A+B 320x320 (126"x126") (9000161) ■ FL-18800

Es. posa A



160x320 (63"x126")
OPEN BOOK A SOFT
OPEN BOOK A GLOSSY

160x320 (63"x126")
OPEN BOOK B SOFT
OPEN BOOK B GLOSSY

Es. posa B

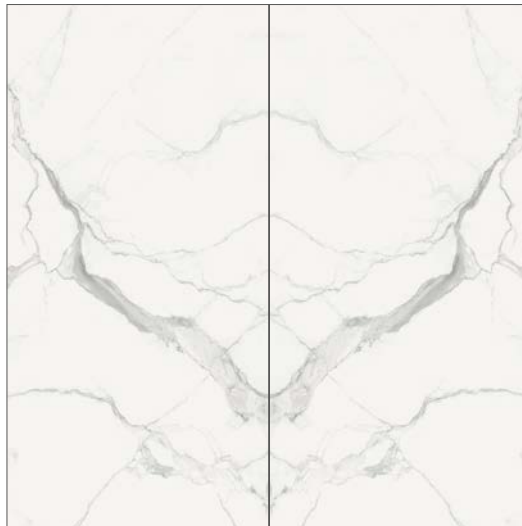

Es. posa C

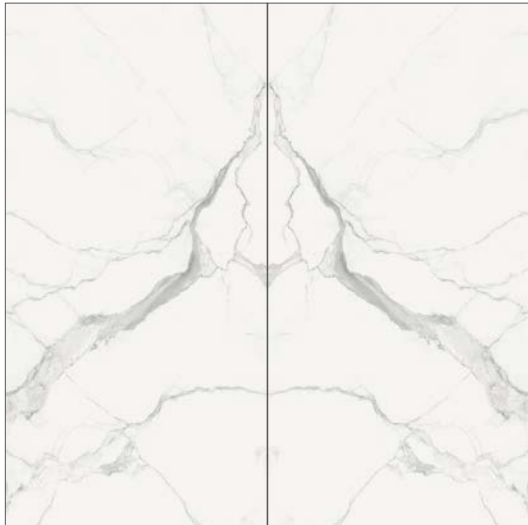

Es. posa D

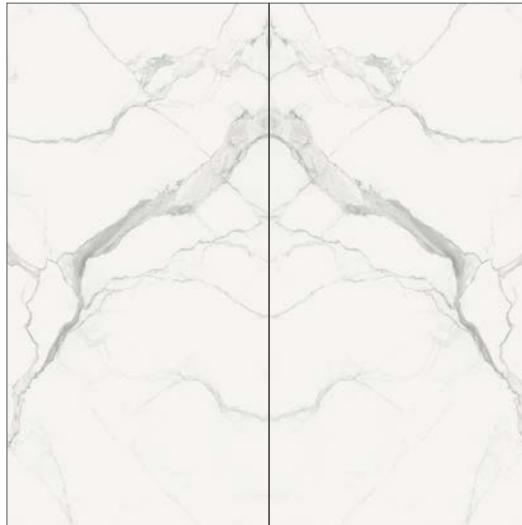

Il disegno riprodotto è indicativo.

Come per il materiale naturale anche la grafica di OPEN BOOK e CHAIN può mostrare discontinuità di vena nel passaggio da una lastra all'altra. Per questo motivo differenze fino a 1,5 cm devono essere considerate come caratteristica del prodotto.

The drawing is purely illustrative.

As with the natural material, the graphic design of OPEN BOOK and CHAIN may result in discontinuities in the veining between panels. Discontinuities of up to 1.5 cm are not defects, but are characteristic of the product.

Le dessin reproduit est indicatif.

De même que le matériau naturel, le graphisme d'OPEN BOOK et de CHAIN peut présenter des marbrures discontinues d'une dalle à l'autre. Pour cette raison, les différences jusqu'à 1,5 cm doivent être considérées comme une caractéristique du produit.

Die wiedergegebene Zeichnung ist eine Musterzeichnung.

Wie für das natürliche Material kann auch die Grafik von OPEN BOOK und CHAIN Brüche der Aderungen beim Übergang von einer Platte zur andern aufweisen. Aus diesem Grund sind Unterschiede bis zu 1,5 cm als Charakteristik des Produkts zu betrachten.

El dibujo es indicativo.

Como el material natural, también la gráfica de OPEN BOOK y CHAIN puede mostrar discontinuidades de la veta al pasar de una losa a otra. Por este motivo, las diferencias de hasta 1,5 cm se deben considerar características del producto.



STATUARIO

CHAIN SOFT A+B+C 360x240 (141^{3/4}"x94^{1/2}") (9000167) ■ FL-11300
 CHAIN GLOSSY A+B+C 360x240 (141^{3/4}"x94^{1/2}") (9000168) ■ FL-14000
 Es. posa A

STATUARIO

CHAIN SOFT D+E+F 360x240 (141^{3/4}"x94^{1/2}") (9000170) ■ FL-11300
 CHAIN GLOSSY D+E+F 360x240 (141^{3/4}"x94^{1/2}") (9000171) ■ FL-14000

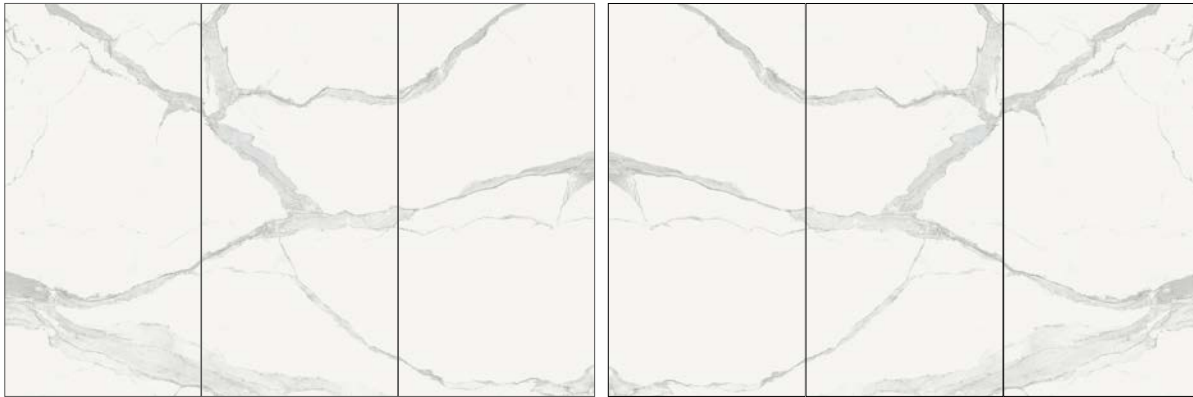

120x240 (47 ^{1/4} "x94 ^{1/2} ") CHAIN A SOFT CHAIN A GLOSSY	120x240 (47 ^{1/4} "x94 ^{1/2} ") CHAIN B SOFT CHAIN B GLOSSY	120x240 (47 ^{1/4} "x94 ^{1/2} ") CHAIN C SOFT CHAIN C GLOSSY	120x240 (47 ^{1/4} "x94 ^{1/2} ") CHAIN D SOFT CHAIN D GLOSSY	120x240 (47 ^{1/4} "x94 ^{1/2} ") CHAIN E SOFT CHAIN E GLOSSY	120x240 (47 ^{1/4} "x94 ^{1/2} ") CHAIN F SOFT CHAIN F GLOSSY
---	---	---	---	---	---

Es. posa B

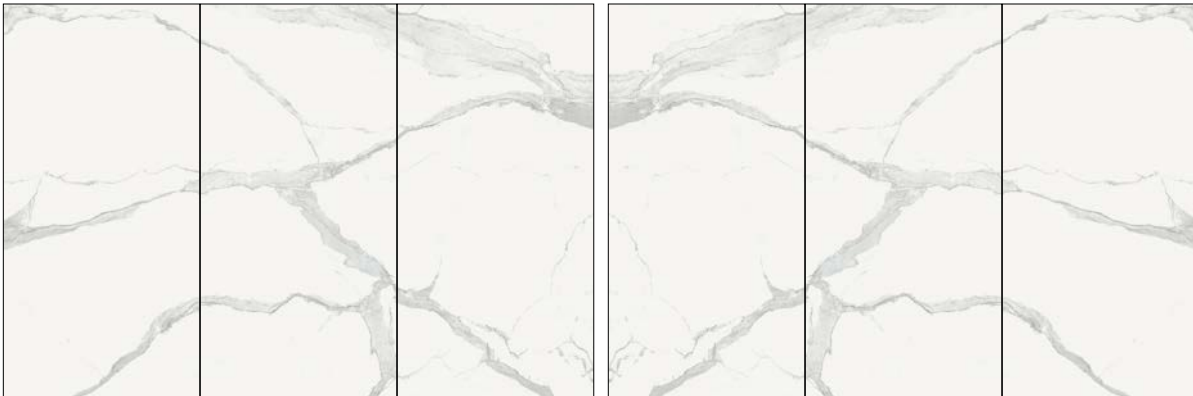

120x240 (47 ^{1/4} "x94 ^{1/2} ") CHAIN C SOFT CHAIN C GLOSSY	120x240 (47 ^{1/4} "x94 ^{1/2} ") CHAIN B SOFT CHAIN B GLOSSY	120x240 (47 ^{1/4} "x94 ^{1/2} ") CHAIN A SOFT CHAIN A GLOSSY	120x240 (47 ^{1/4} "x94 ^{1/2} ") CHAIN F SOFT CHAIN F GLOSSY	120x240 (47 ^{1/4} "x94 ^{1/2} ") CHAIN E SOFT CHAIN E GLOSSY	120x240 (47 ^{1/4} "x94 ^{1/2} ") CHAIN D SOFT CHAIN D GLOSSY
---	---	---	---	---	---



I CLASSICI

CALACATTA GOLD

OPEN BOOK MATTE A+B 320x320 (126"x126") (9000191) ■ FL-15600

OPEN BOOK GLOSSY A+B 320x320 (126"x126") (9000176) ■ FL-18800

Es. posa A



160x320 (63"x126")
OPEN BOOK A MATTE
OPEN BOOK A GLOSSY

160x320 (63"x126")
OPEN BOOK B MATTE
OPEN BOOK B GLOSSY

Es. posa B



Il disegno riprodotto è indicativo.

Come per il materiale naturale anche la grafica di OPEN BOOK e CHAIN può mostrare discontinuità di vena nel passaggio da una lastra all'altra. Per questo motivo differenze fino a 1,5 cm devono essere considerate come caratteristica del prodotto.

The drawing is purely illustrative.

As with the natural material, the graphic design of OPEN BOOK and CHAIN may result in discontinuities in the veining between panels. Discontinuities of up to 1.5 cm are not defects, but are characteristic of the product.

Le dessin reproduit est indicatif.

De même que le matériau naturel, le graphisme d'OPEN BOOK et de CHAIN peut présenter des marbrures discontinues d'une dalle à l'autre. Pour cette raison, les différences jusqu'à 1,5 cm doivent être considérées comme une caractéristique du produit.

Die wiedergegebene Zeichnung ist eine Musterzeichnung.

Wie für das natürliche Material kann auch die Grafik von OPEN BOOK und CHAIN Brüche der Aderungen beim Übergang von einer Platte zur andern aufweisen. Aus diesem Grund sind Unterschiede bis zu 1,5 cm als Charakteristik des Produkts zu betrachten.

El dibujo es indicativo.

Como el material natural, también la gráfica de OPEN BOOK y CHAIN puede mostrar discontinuidades de la veta al pasar de una losa a otra. Por este motivo, las diferencias de hasta 1,5 cm se deben considerar características del producto.



CALACATTA GOLD

CHAIN MATTE A+B+C 360x240 (141^{3/4"}x94^{1/2"}) (9000188) ■ FL-11300
 CHAIN GLOSSY A+B+C 360x240 (141^{3/4"}x94^{1/2"}) (9000179) ■ FL-14000
 Es. posa A

CALACATTA GOLD

CHAIN MATTE F+E+D 360x240 (141^{3/4"}x94^{1/2"}) (9000189) ■ FL-11300
 CHAIN GLOSSY F+E+D 360x240 (141^{3/4"}x94^{1/2"}) (9000180) ■ FL-14000

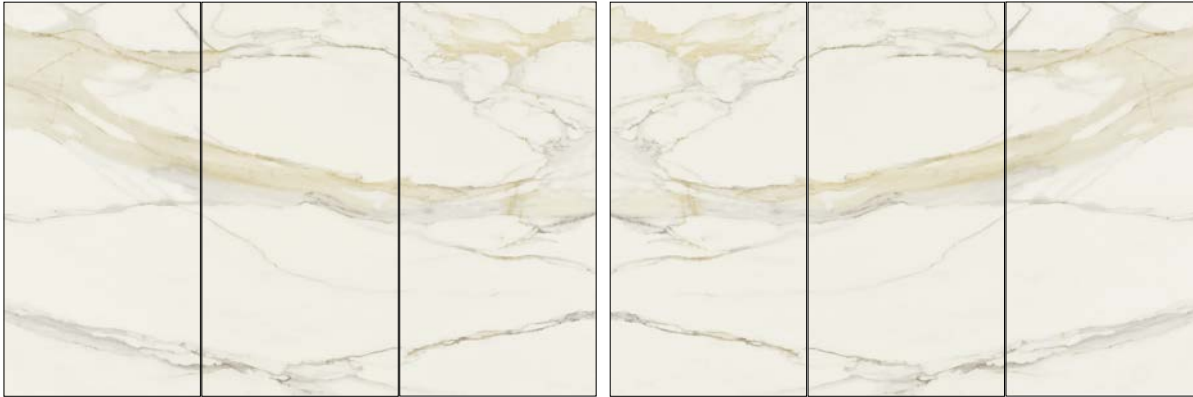

120x240 (47^{1/8"}x94^{1/2"})
 CHAIN A MATTE
 CHAIN A GLOSSY

120x240 (47^{1/8"}x94^{1/2"})
 CHAIN B MATTE
 CHAIN B GLOSSY

120x240 (47^{1/8"}x94^{1/2"})
 CHAIN C MATTE
 CHAIN C GLOSSY

120x240 (47^{1/8"}x94^{1/2"})
 CHAIN F MATTE
 CHAIN F GLOSSY

120x240 (47^{1/8"}x94^{1/2"})
 CHAIN E MATTE
 CHAIN E GLOSSY

120x240 (47^{1/8"}x94^{1/2"})
 CHAIN D MATTE
 CHAIN D GLOSSY

Es. posa B

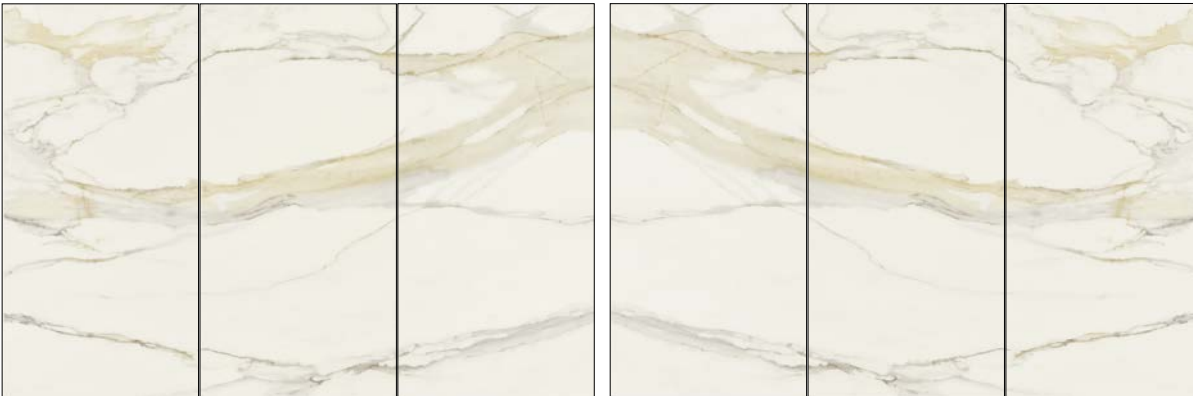

120x240 (47^{1/8"}x94^{1/2"})
 CHAIN F MATTE
 CHAIN F GLOSSY

120x240 (47^{1/8"}x94^{1/2"})
 CHAIN E MATTE
 CHAIN E GLOSSY

120x240 (47^{1/8"}x94^{1/2"})
 CHAIN D MATTE
 CHAIN D GLOSSY

120x240 (47^{1/8"}x94^{1/2"})
 CHAIN A MATTE
 CHAIN A GLOSSY

120x240 (47^{1/8"}x94^{1/2"})
 CHAIN B MATTE
 CHAIN B GLOSSY

120x240 (47^{1/8"}x94^{1/2"})
 CHAIN C MATTE
 CHAIN C GLOSSY

I CLASSICI

9 mm 3/8" ↑↓	COLOR	SURFACE	30x30 11 4/5" x 11 4/5"	30x30 11 4/5" x 11 4/5"	4,6x60 1 4/5" x 23 5/8"	33x120x3 13" x 47 1/4" x 1 1/8"
			mosaico tessere 3x15 pz/box 11	mosaico 3D tessere 3x3 pz/box 9	battiscopa	gradino pz/box 2
	STATUARIO	GLOSSY	748340 ▲ FL-02200	748341 ▲ FL-04900	748343 ◆ FL-01600	748345 ▲ FL-22600
		SOFT	748339 ▲ FL-02100		748342 ◆ FL-01600	748344 ▲ FL-20400
	CALACATTA GOLD	GLOSSY	750721 ▲ FL-02200	750710 ▲ FL-04900	750722 ◆ FL-01600	750723 ▲ FL-22600
		MATTE	753299 ▲ FL-02100		753300 ◆ FL-01600	753301 ▲ FL-20400
	MARQUINIA	GLOSSY	750879 ▲ FL-02200	750880 ▲ FL-04900	750881 ◆ FL-01600	750882 ▲ FL-22600
		MATTE	751918 ▲ FL-01700		751919 ◆ FL-01600	751920 ▲ FL-20400
	BRAZILIAN	GLOSSY	750903 ▲ FL-02200	750902 ▲ FL-04900	750918 ◆ FL-01600	750919 ▲ FL-22600
	PORTORO	GLOSSY	750917 ▲ FL-02200	750916 ▲ FL-04900	750920 ◆ FL-01600	750921 ▲ FL-22600

9 mm 3/8" ↑↓	COLOR	SURFACE	4,6x60 1 4/5" x 23 5/8"
			battiscopa
	DECÒ WOOD WHITE	MATTE	750062 ◆ FL-01600
	DECÒ WOOD PEARL	MATTE	750063 ◆ FL-01600
	DECÒ WOOD BLACK	MATTE	750064 ◆ FL-01600

9 mm 3/8" ↑↓

Product Certification
BUREAU VERITAS
Certification

Recycled material content certification





I formati 160x160 e 80x240 possono essere acquistati solo a multipli di 2 lastre. / Sales unit for 160x160 and 80x240 is 2 pcs, so they can only be bought in multiples of 2. / Les formats 160x160 et 80x240 sont vendus par multiples de 2 plaques / Die Formate 160x160 und 80x240 können nur in einer durch 2 teilbaren Anzahl bestellt werden / Las medidas 160x160 y 80x240 solo pueden comprarse en múltiplos de 2 placas

Nelle operazioni di posa a listoni sfalsati, si raccomanda sempre di fare in modo che il lato maggiore della piastrella termini a circa un terzo della lunghezza di quelle accanto (posa sfalsata "a 1/3"). - When installing staggered strips, we recommend that the tile's longer side should always end at about one-third of the length of the tiles next to it ("1/3" staggered installation) - Lors de la pose des listels décalés, il faut toujours faire en sorte que le côté le plus grand du carreau se trouve à environ 1/3 de la longueur des carreaux d'à côté (pose décalée "à 1/3"). - Beim Verlegen der Leisten in versetzter Form ist zu beachten, dass die höhere Seite der Fliese immer circa bei einem Drittels der Länge der sich daneben befindlichen Fliesen abschließt ("Um 1/3" versetzte Verlegung) - En las operaciones de colocación de listones escalonados, se recomienda hacerlo siempre de forma tal que el lado mayor del azulejo termine teniendo alrededor de un tercio de la longitud de los contiguos (colocación escalonada "a 1/3").

Per un effetto ottimale della posa, florim suggerisce di mantenere 2 mm di fuga per pose monofornato e 3 mm per combinare formati misti. - For optimal installation results, florim recommends maintaining a joint of 2 mm 1/12" for single format installations and 3 mm 1/8" to combine mixed formats. - Pour réaliser une pose parfaite, florim suggère de maintenir 2 mm de joint pour la pose des monofornats, et 3 mm pour les combinaisons de formats mixtes. - Um einen optimalen Effekt beim Verlegen zu erzielen empfiehlt florim eine 2 mm fuge bei einformatigen Verlegungen und 3 mm fuge bei formatkombinationen Para lograr los máximos resultados en la posa del producto, florim aconseja 2 mm de junta en aplicaciones monofornato y 3 mm en combinaciones de formatos mixtos.

I CLASSICI	scatola - box			pallet		
	pz	mq	kg	box	mq	kg
80x180	2	2,88	57,60	20	57,60	1210
60x120	2	1,44	28,08	30	43,20	870
80x80	2	1,28	24,96	40	51,20	1030
60x60	3	1,08	21,06	40	43,20	870
30x60	6	1,08	20,84	40	43,20	860

I CLASSICI	scatola - box			pallet		
	pz	ml	kg	box	mq	kg
4,6x60 battiscopa	14	8,40	8,40	-	-	-

6 mm 1/4" ↑↓				30x30 11 4/5" x 11 4/5"	30x30 11 4/5" x 11 4/5"
	COLOR	SURFACE			
I CLASSICI		STATUARIO	GLOSSY	747773 ▲ FL-02100	747803 ▲ FL-02100
			SOFT	747772 ▲ FL-01800	747802 ▲ FL-01800
		CALACATTA GOLD	GLOSSY	750869 ▲ FL-02100	750871 ▲ FL-02100
			MATTE	753302 ▲ FL-01800	753303 ▲ FL-01800
		MARQUINIA	GLOSSY	750887 ▲ FL-02100	750888 ▲ FL-02100
			MATTE	751925 ▲ FL-01800	751927 ▲ FL-01800

PEZZI SPECIALI/SPECIAL TRIMS/PIÈCES SPÉCIALES/FORMSTÜCKE/PIEZAS ESPECIALES

6 mm 1/4" ↑↓				4,6x80 1 4/5" x 3 1/2"
	COLOR	SURFACE		
I CLASSICI		STATUARIO	GLOSSY	747888 ◆ FL-01800
			SOFT	747887 ◆ FL-01800
		CALACATTA GOLD	GLOSSY	750873 ◆ FL-01800
			MATTE	753304 ◆ FL-01800
		MARQUINIA	GLOSSY	750889 ◆ FL-01800
			MATTE	751928 ◆ FL-01800

In relazione alle differenti tecnologie produttive l'accostamento di prodotti con spessori diversi potrebbe presentare delle disomogeneità, se ne sconsiglia pertanto l'abbinamento. / Due to the different production technologies, contiguous installation of products with different thickness may give a non-homogeneous result. For this reason we do not recommend this option. / Vu que différentes technologies de production sont utilisées avec des épaisseurs différentes, des problèmes d'homogénéité pourraient se présenter, il est donc déconseillé de les poser ensemble. / Wegen unterschiedlicher Produktionstechnologien können die Fliesen mit verschiedenen Materialstärken optische Differenzen aufweisen. Von einem direkten Aneinanderlegen wird deshalb abgeraten. / Dadas las diferentes tecnologías productivas, la combinación de productos de diferentes espesores podría dar lugar a heterogeneidad, por lo que se desaconseja mezclarlas.

FLORIM OVERSIZE
magnlum

160x320/120x280/160x160/120x240/120x120/60x120
 Specifica Imballo pag.
 Packaging specifications on page
 Spécifications d'emballage à page
 Verpackungsdetail Seite
 Especificaciones de embalaje a la página
204/205



I FILATI

gres porcellanato decorato
decorated porcelain tiles
grès cérame décoré
verziertes feinsteinzeug
gres porcelánico decorado

RUBELLI
design





I FILATI

“**I Filati - Rubelli Design**”, la nuova collezione ideata da Florim in collaborazione con Rubelli, aziende di riferimento italiane nel campo del design, sebbene di settori differenti, sono appassionate a tutto quello che fa rima con Arte e Bellezza. Si tratta di due realtà simili e, allo stesso tempo, profondamente diverse, capaci di tendersi la mano per dare vita ad un progetto unico che mette insieme l'ingegno e l'esperienza che appartengono alla cultura imprenditoriale italiana di qualità. Il prodotto ceramico rievoca il senso di artigianalità della secolare arte della seta attraverso lastre ceramiche di grande formato che si presentano come tessuti innovativi, seducenti alla vista e gradevoli al tatto, capaci di conservare intatta l'essenza e la preziosità di quelli artigianali.

“**I Filati - Rubelli Design**” is the new collection designed by Florim in collaboration with Rubelli. Italian key players in the field of design, although in different sectors, they are passionate about everything that rhymes with Art and Beauty. These two similar yet at the same time profoundly different companies have joined forces, giving life to a unique project that brings together the skill and experience that are hallmarks of high-quality Italian entrepreneurial culture. The ceramic product calls to mind the craftsmanship of the centuries-old art of silk-weaving, through large-size ceramic panels that resemble innovative fabrics, alluring to the eye and pleasing to the touch, able to preserve the very essence and fineness of hand-spun silk.

« **I Filati - Rubelli Design** », la nouvelle collection élaborée par Florim en collaboration avec Rubelli, des sociétés de référence dans le secteur du design, chacune avec un domaine de compétence différent, sont passionnées par tout ce qui rime avec Art et Beauté. Deux sociétés à la fois semblables et profondément différentes qui se tendent la main pour donner naissance à un projet unique combinant le génie et l'expérience, à savoir des caractéristiques typiques de la culture entrepreneuriale italienne de qualité. Le produit céramique évoque le caractère artisanal de l'art séculaire de la soie à travers des dalles céramiques grand format qui se présentent comme des tissus innovants, séduisants à l'œil et agréables au toucher, qui savent conserver intactes l'essence et la préciosité des tissus artisanaux.

„**I Filati - Rubelli Design**“, die neue Kollektion, die Florim in Zusammenarbeit mit Rubelli schuf. Zwei renommierte italienische Designunternehmen, die trotz ihrer verschiedenen Sektoren eine große Leidenschaft für alles hegen, was sich mit Kunst und Schönheit reimt. Es handelt sich um zwei ähnliche und zugleich zutiefst unterschiedliche Firmen, die sich zusammentun, um ein einzigartiges Projekt zu verwirklichen, das den Einfallsreichtum und die Erfahrung der hochwertigen Unternehmenskultur Italiens vereint. Das Keramikprodukt weckt die Erinnerung an den Handwerkssinn der jahrhundertealten Seidenkunst durch große Keramikplatten, die sich dem Auge als verführerische und zudem angenehm weiche Stoffe entpuppen, die das Wesen und die Kostbarkeit der handwerklich hergestellten Erzeugnisse voll und ganz bewahren.

“**I Filati - Rubelli Design**”, la nueva colección creada por Florim en colaboración con Rubelli, empresas italianas de referencia en el ámbito del diseño, aunque en sectores distintos, que sienten pasión por todo lo que rima con Arte y Belleza. Se trata de dos empresas parecidas y, al mismo tiempo, profundamente distintas, capaces de darse la mano para dar vida a un proyecto único que combina el ingenio y la experiencia característicos de la cultura empresarial italiana de calidad. El producto cerámico evoca el sentido de artesanía del arte secular de la seda a través de losas cerámicas de gran formato que se presentan como tejidos innovadores, seductores a la vista y agradables al tacto, capaces de conservar intacta la esencia y la belleza de los artesanales.

I FILATI

LADY HAMILTON VANIGLIA



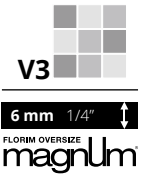

LADY HAMILTON TURCHESE



GRES PORCELLANATO DECORATO

DECORATED PORCELAIN TILES/GRÈS CÉRAMÉ DÉCORÉ/VERZIERTES FEINSTEINZEUG/GRES PORCELÁNICO DECORADO
SQUADRATO - SQUARED - EQUARRI - REKTIFIZIERT - ESCUADRADO

6 mm 1/4" ↑↓		COLOR	SURFACE	120x280 47 ^{11/16"} x110 ^{1/4"}	120x240 47 ^{11/16"} x94 ^{1/2"}	60x120 A 23 ^{5/8"} x47 ^{1/4"}	60x120 B 23 ^{5/8"} x47 ^{1/4"}	60x120 C 23 ^{5/8"} x47 ^{1/4"}	60x120 D 23 ^{5/8"} x47 ^{1/4"}	60x120 23 ^{5/8"} x47 ^{1/4"} A+B+C+D
I FILATI		LADY HAMILTON VANIGLIA	MATTE	767040 ■ FL-42900	767075 ■ FL-42900	767110 ■ FL-39700	769124 ■ FL-39700	769125 ■ FL-39700	769126 ■ FL-39700	9000202 ■ FL-39700
		LADY HAMILTON TURCHESE	MATTE	767042 ■ FL-42900	767077 ■ FL-42900	767114 ■ FL-39700	769191 ■ FL-39700	769192 ■ FL-39700	769193 ■ FL-39700	9000203 ■ FL-39700

RUBELLI
design

LADY HAMILTON CIPRIA



LADY HAMILTON AMARANTO

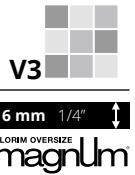
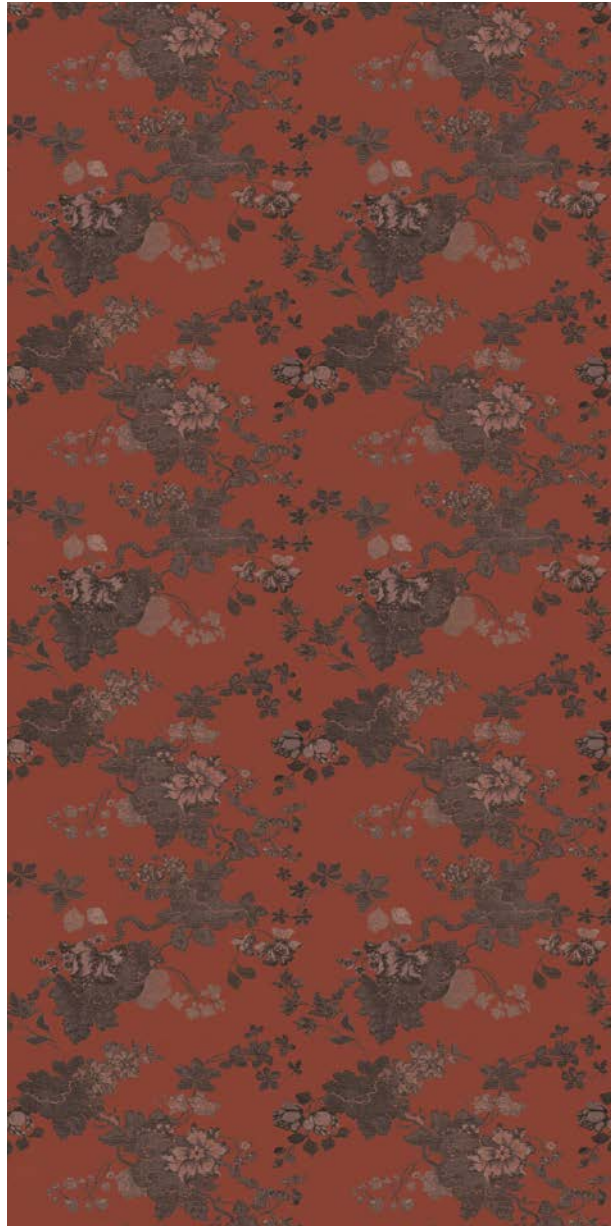

GRES PORCELLANATO DECORATO
 DECORATED PORCELAIN TILES/GRES CÉRAMÉ DÉCORÉ/VERZIERTES FEINSTEINZEUG/GRES PORCELÁNICO DECORADO
 SQUADRATO - SQUARED - EQUARRI - REKTIFIZIERT - ESCUADRADO

6 mm 1/4" ↑↓		COLOR	SURFACE	120x280 47 ^{11/16"} x110 ^{1/4"}	120x240 47 ^{1/4"} x94 ^{1/2"}	60x120 A 23 ^{5/8"} x47 ^{1/4"}	60x120 B 23 ^{5/8"} x47 ^{1/4"}	60x120 C 23 ^{5/8"} x47 ^{1/4"}	60x120 D 23 ^{5/8"} x47 ^{1/4"}	60x120 23 ^{5/8"} x47 ^{1/4"} A+B+C+D
I FILATI		LADY HAMILTON CIPRIA	MATTE	767041 ■ FL-42900	767076 ■ FL-42900	767113 ■ FL-39700	769109 ■ FL-39700	769110 ■ FL-39700	769111 ■ FL-39700	9000204 ■ FL-39700
		LADY HAMILTON AMARANTO	MATTE	767043 ■ FL-42900	767078 ■ FL-42900	767115 ■ FL-39700	769160 ■ FL-39700	769161 ■ FL-39700	769162 ■ FL-39700	9000205 ■ FL-39700

I FILATI

FUNNY GIRL VANIGLIA





FUNNY GIRL TURCHESE



6 mm 1/4" ↑
 FLORIM OVERSIZE
 magnUm

GRES PORCELLANATO DECORATO

DECORATED PORCELAIN TILES/GRÈS CÉRAMÉ DÉCORÉ/VERZIERTES FEINSTEINZEUG/GRES PORCELÁNICO DECORADO
 SQUADRATO - SQUARED - EQUARRI - REKTIFIZIERT - ESCUADRADO

		6 mm 1/4" ↑		COLOR	SURFACE	120x280 47 ^{11/16"} x110 ^{1/4"}	120x240 47 ^{11/16"} x94 ^{1/2"}	60x120 A 23 ^{5/8"} x47 ^{1/4"}	60x120 B 23 ^{5/8"} x47 ^{1/4"}	60x120 C 23 ^{5/8"} x47 ^{1/4"}	60x120 D 23 ^{5/8"} x47 ^{1/4"}	60x120 23 ^{5/8"} x47 ^{1/4"} A+B+C+D
I FILATI		FUNNY GIRL VANIGLIA	MATTE	767044 ■ FL-42900	767079 ■ FL-42900	767116 ■ FL-39700	769118 ■ FL-39700	769119 ■ FL-39700	769120 ■ FL-39700	9000206 ■ FL-39700		
		FUNNY GIRL TURCHESE	MATTE	767046 ■ FL-42900	767081 ■ FL-42900	767118 ■ FL-39700	769188 ■ FL-39700	769189 ■ FL-39700	769190 ■ FL-39700	9000207 ■ FL-39700		

RUBELLI
 design

FUNNY GIRL CIPRIA



FUNNY GIRL GRANATA



6 mm 1/4" ↑
FLORM OVERSIZE
magnUm

GRES PORCELLANATO DECORATO
DECORATED PORCELAIN TILES/GRES CÉRAMÉ DÉCORÉ/VERZIERTES FEINSTEINZEUG/GRES PORCELÁNICO DECORADO
SQUADRATO - SQUARED - EQUARRI - REKTIFIZIERT - ESCUADRADO

6 mm 1/4" ↑		COLOR	SURFACE	120x280 47 ^{11/16"} x110 ^{1/4"}	120x240 47 ^{11/16"} x94 ^{1/2"}	60x120 A 23 ^{5/8"} x47 ^{1/4"}	60x120 B 23 ^{5/8"} x47 ^{1/4"}	60x120 C 23 ^{5/8"} x47 ^{1/4"}	60x120 D 23 ^{5/8"} x47 ^{1/4"}	60x120 23 ^{5/8"} x47 ^{1/4"} A+B+C+D
I FILATI		FUNNY GIRL CIPRIA	MATTE	767045 ■ FL-42900	767080 ■ FL-42900	767117 ■ FL-39700	769103 ■ FL-39700	769104 ■ FL-39700	769105 ■ FL-39700	9000208 ■ FL-39700
		FUNNY GIRL GRANATA	MATTE	767048 ■ FL-42900	767083 ■ FL-42900	767120 ■ FL-39700	769175 ■ FL-39700	769176 ■ FL-39700	769177 ■ FL-39700	9000209 ■ FL-39700

RUBELLI
design

I FILATI



DORIAN GRAY RUGIADA

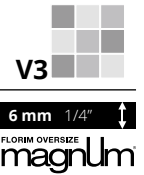

DORIAN GRAY FIORDALISO



GRES PORCELLANATO DECORATO
 DECORATED PORCELAIN TILES/GRÈS CÉRAMÉ DÉCORÉ/VERZIERTES FEINSTEINZEUG/GRES PORCELÁNICO DECORADO
 SQUADRATO - SQUARED - EQUARRI - REKTIFIZIERT - ESCUADRADO

		6 mm 1/4" ↑↓		COLOR	SURFACE	120x280 47 ^{11/16"} x110 ^{1/4"}	120x240 47 ^{11/16"} x94 ^{1/2"}	60x120 A 23 ^{5/8"} x47 ^{1/4"}	60x120 B 23 ^{5/8"} x47 ^{1/4"}	60x120 C 23 ^{5/8"} x47 ^{1/4"}	60x120 D 23 ^{5/8"} x47 ^{1/4"}	60x120 23 ^{5/8"} x47 ^{1/4"} A+B+C+D
I FILATI		DORIAN GRAY RUGIADA	MATTE	767049 ■ FL-42900	767084 ■ FL-42900	767121 ■ FL-39700	769097 ■ FL-39700	769098 ■ FL-39700	769099 ■ FL-39700	9000210 ■ FL-39700		
		DORIAN GRAY FIORDALISO	MATTE	767051 ■ FL-42900	767086 ■ FL-42900	767123 ■ FL-39700	769203 ■ FL-39700	769204 ■ FL-39700	769205 ■ FL-39700	9000211 ■ FL-39700		

RUBELLI
design

DORIAN GRAY GLICINE

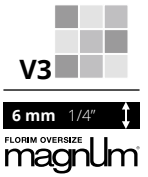

GRES PORCELLANATO DECORATO
 DECORATED PORCELAIN TILES/GRES CÉRAMÉ DÉCORÉ/VERZIERTES FEINSTEINZEUG/GRES PORCELÁNICO DECORADO
 SQUADRATO - SQUARED - EQUARRI - REKTIFIZIERT - ESCUADRADO

6 mm 1/4" ↑↓	COLOR	SURFACE	120x280 47 ^{1/4"} x110 ^{1/4"}	120x240 47 ^{1/4"} x94 ^{1/2"}	60x120 A 23 ^{5/8"} x47 ^{1/4"}	60x120 B 23 ^{5/8"} x47 ^{1/4"}	60x120 C 23 ^{5/8"} x47 ^{1/4"}	60x120 D 23 ^{5/8"} x47 ^{1/4"}	60x120 23 ^{5/8"} x47 ^{1/4"} A+B+C+D
I FILATI	 DORIAN GRAY GLICINE	MATTE	767050 ■ FL-42900	767085 ■ FL-42900	767122 ■ FL-39700	769151 ■ FL-39700	769152 ■ FL-39700	769153 ■ FL-39700	9000212 ■ FL-39700

RUBELLI
design

I FILATI

GOLDFINGER RUGIADA

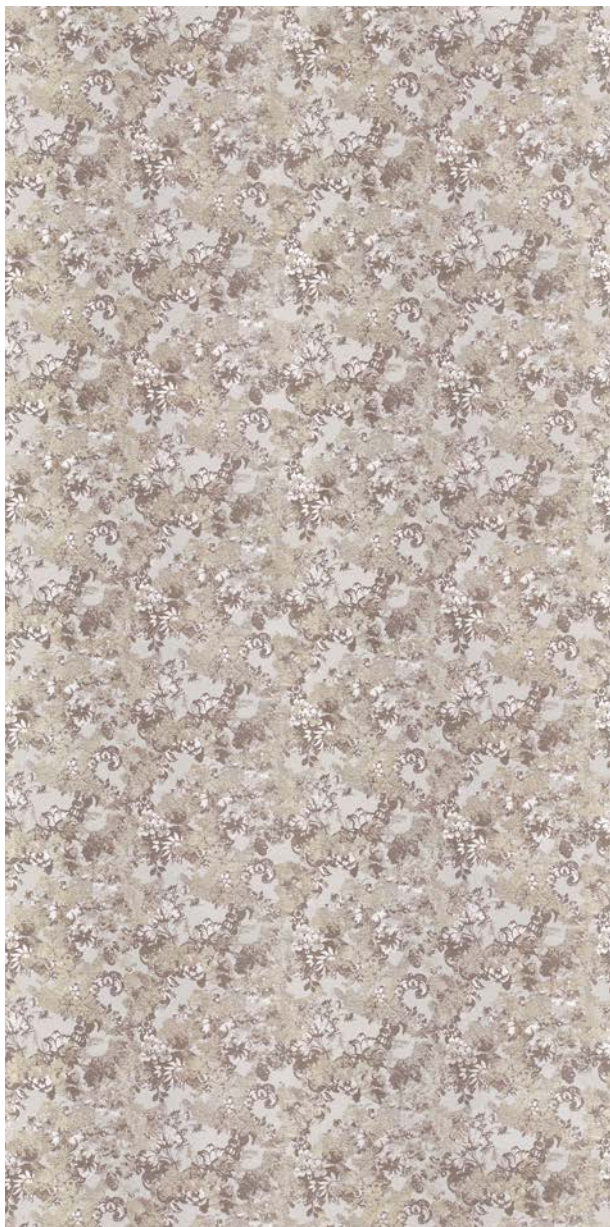

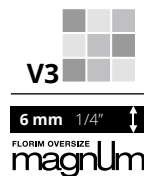
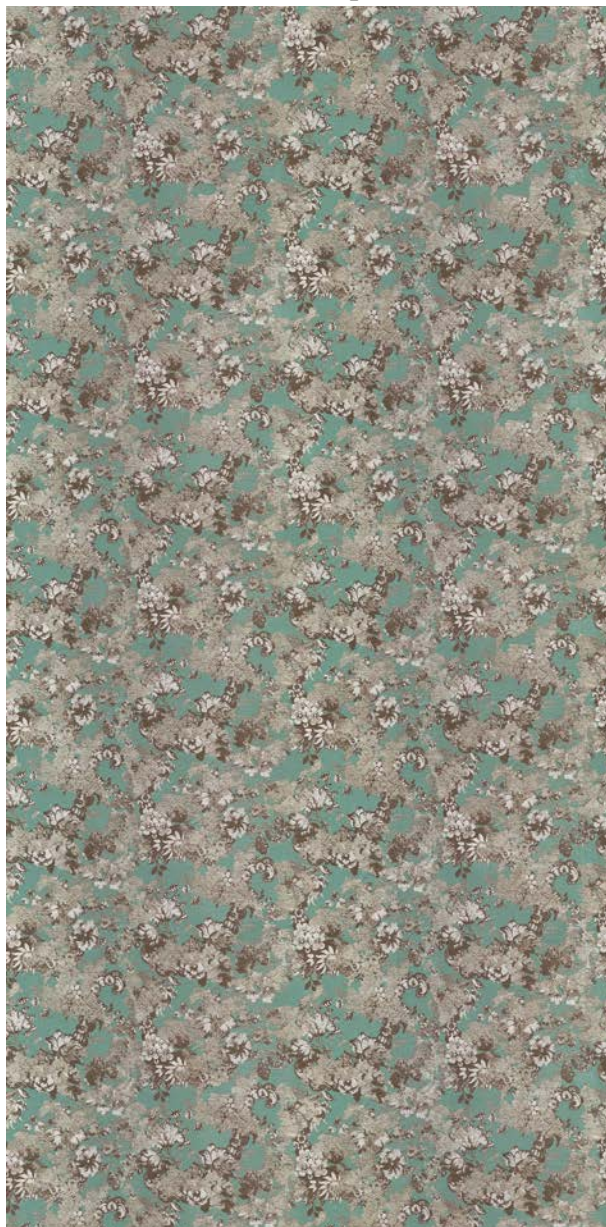

GOLDFINGER ACQUAMARINA



GRES PORCELLANATO DECORATO

DECORATED PORCELAIN TILES / GRÈS CÉRAME DÉCORÉ / VERZIERTES FEINSTEINZEUG / GRES PORCELÁNICO DECORADO

SQUADRATO - SQUARED - EQUARRI - REKTIFIZIERT - ESCUADRADO

		6 mm 1/4" ↑↓		COLOR	SURFACE	120x280 47 ^{11/16"} x110 ^{1/4"}	120x240 47 ^{11/16"} x94 ^{1/2"}	60x120 A 23 ^{5/8"} x47 ^{1/4"}	60x120 B 23 ^{5/8"} x47 ^{1/4"}	60x120 C 23 ^{5/8"} x47 ^{1/4"}	60x120 D 23 ^{5/8"} x47 ^{1/4"}	60x120 23 ^{5/8"} x47 ^{1/4"} A+B+C+D
I FILATI		GOLDFINGER RUGIADA	MATTE	767064 ■ FL-42900	767099 ■ FL-42900	767136 ■ FL-39700	769100 ■ FL-39700	769101 ■ FL-39700	769101 ■ FL-39700	769102 ■ FL-39700	9000213 ■ FL-39700	
		GOLDFINGER ACQUAMARINA	MATTE	767066 ■ FL-42900	767101 ■ FL-42900	767138 ■ FL-39700	769185 ■ FL-39700	769186 ■ FL-39700	769187 ■ FL-39700	9000214 ■ FL-39700		



RUBELLI
design

GOLDFINGER GLICINE

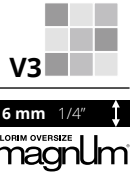
GOLDFINGER GRANATA



GRES PORCELLANATO DECORATO
 DECORATED PORCELAIN TILES/GRES CÉRAMÉ DÉCORÉ/VERZIERTES FEINSTEINZEUG/GRES PORCELÁNICO DECORADO
 SQUADRATO - SQUARED - EQUARRI - REKTIFIZIERT - ESCUADRADO

		6 mm 1/4" ↑↓		COLOR	SURFACE	120x280 47 ^{1/4"} x110 ^{1/4"}	120x240 47 ^{1/4"} x94 ^{1/2"}	60x120 A 23 ^{5/8"} x47 ^{1/4"}	60x120 B 23 ^{5/8"} x47 ^{1/4"}	60x120 C 23 ^{5/8"} x47 ^{1/4"}	60x120 D 23 ^{5/8"} x47 ^{1/4"}	60x120 23 ^{5/8"} x47 ^{1/4"} A+B+C+D
I FILATI		GOLDFINGER GLICINE	MATTE	767065 ■ FL-42900	767100 ■ FL-42900	767137 ■ FL-39700	769154 ■ FL-39700	769155 ■ FL-39700	769156 ■ FL-39700	9000215 ■ FL-39700		
		GOLDFINGER GRANATA	MATTE	767067 ■ FL-42900	767102 ■ FL-42900	767139 ■ FL-39700	769178 ■ FL-39700	769179 ■ FL-39700	769181 ■ FL-39700	9000216 ■ FL-39700		

RUBELLI
design

I FILATI

BESTEGUI AVORIO ANTICO





BESTEGUI AMBRA



6 mm 1/4" ↑
 FLORIM OVERSIZE
 magnUm

GRES PORCELLANATO DECORATO

DECORATED PORCELAIN TILES / GRÈS CÉRAMÉ DÉCORÉ / VERZIERTES FEINSTEINZEUG / GRES PORCELÁNICO DECORADO
 SQUADRATO - SQUARED - EQUARRI - REKTIFIZIERT - ESCUADRADO

6 mm 1/4" ↑	COLOR	SURFACE	120x280 47 ^{11/16"} x110 ^{1/4"}	120x240 47 ^{11/16"} x94 ^{1/2"}	60x120 A 23 ^{5/8"} x47 ^{1/4"}	60x120 B 23 ^{5/8"} x47 ^{1/4"}	60x120 C 23 ^{5/8"} x47 ^{1/4"}	60x120 D 23 ^{5/8"} x47 ^{1/4"}	60x120 23 ^{5/8"} x47 ^{1/4"} A+B+C+D
	BESTEGUI AVORIO ANTICO	MATTE	767052 ■ FL-42900	767087 ■ FL-42900	767124 ■ FL-39700	769087 ■ FL-39700	769089 ■ FL-39700	769090 ■ FL-39700	9000217 ■ FL-39700
	BESTEGUI AMBRA	MATTE	767053 ■ FL-42900	767088 ■ FL-42900	767125 ■ FL-39700	769133 ■ FL-39700	769134 ■ FL-39700	769135 ■ FL-39700	9000218 ■ FL-39700

RUBELLI
design

BESTEGUI GRANATA

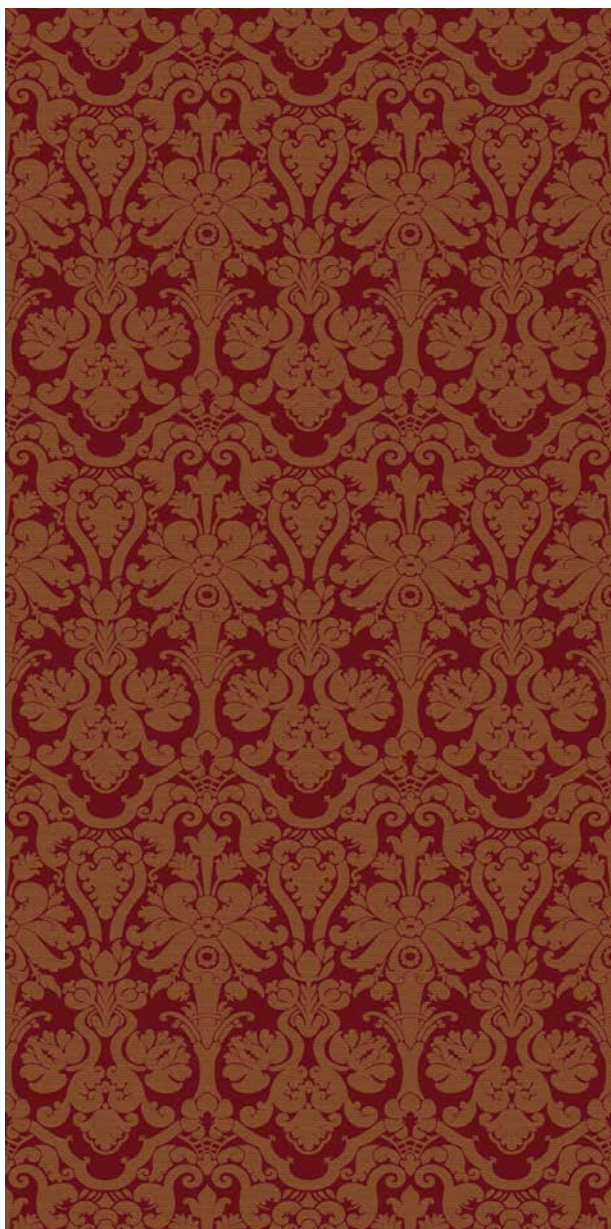

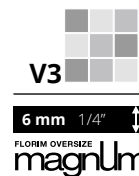
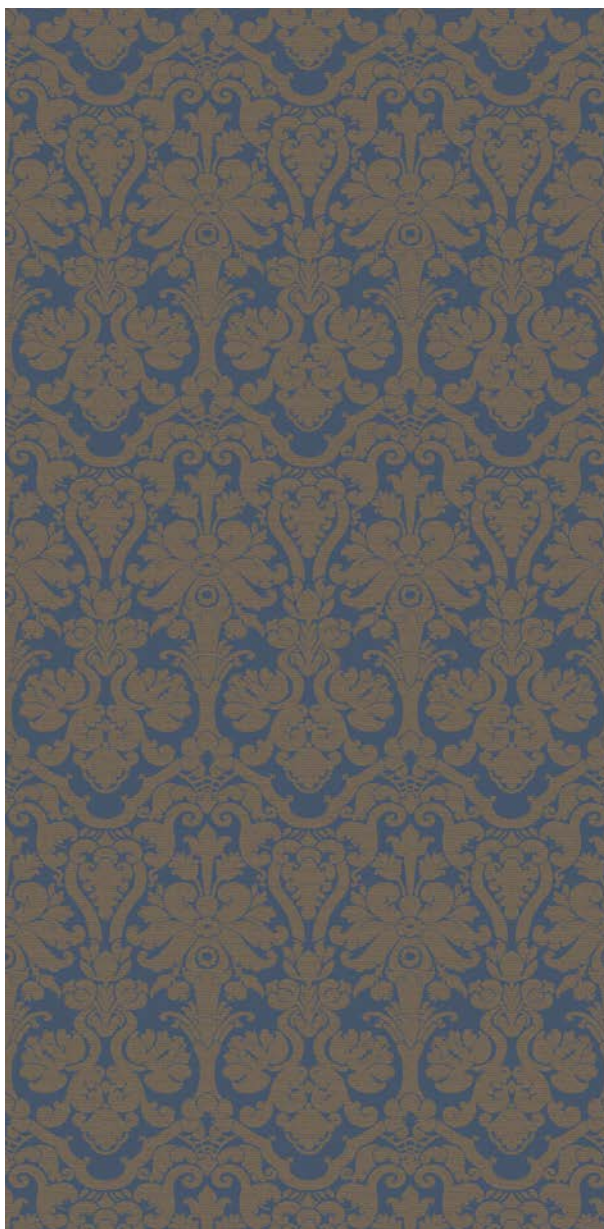

BESTEGUI BLU DI PRUSSIA



GRES PORCELLANATO DECORATO

DECORATED PORCELAIN TILES/GRÉS CÉRAMÉ DÉCORÉ/VERZIERTES FEINSTEINZEUG/GRES PORCELÁNICO DECORADO
SQUADRATO - SQUARED - EQUARRI - REKTIFIZIERT - ESCUADRADO

		6 mm 1/4" ↑↓		COLOR	SURFACE	120x280 47 ^{1/4"} x110 ^{1/4"}	120x240 47 ^{1/4"} x94 ^{1/2"}	60x120 A 23 ^{5/8"} x47 ^{1/4"}	60x120 B 23 ^{5/8"} x47 ^{1/4"}	60x120 C 23 ^{5/8"} x47 ^{1/4"}	60x120 D 23 ^{5/8"} x47 ^{1/4"}	60x120 23 ^{5/8"} x47 ^{1/4"} A+B+C+D
I FILATI		BESTEGUI GRANATA	MATTE	767054 ■ FL-42900	767089 ■ FL-42900	767126 ■ FL-39700	769169 ■ FL-39700	769170 ■ FL-39700	769171 ■ FL-39700	9000219 ■ FL-39700		
		BESTEGUI BLU DI PRUSSIA	MATTE	767055 ■ FL-42900	767090 ■ FL-42900	767127 ■ FL-39700	769194 ■ FL-39700	769195 ■ FL-39700	769196 ■ FL-39700	9000220 ■ FL-39700		

RUBELLI
design

I FILATI

SAN MARCO AVORIO ANTICO



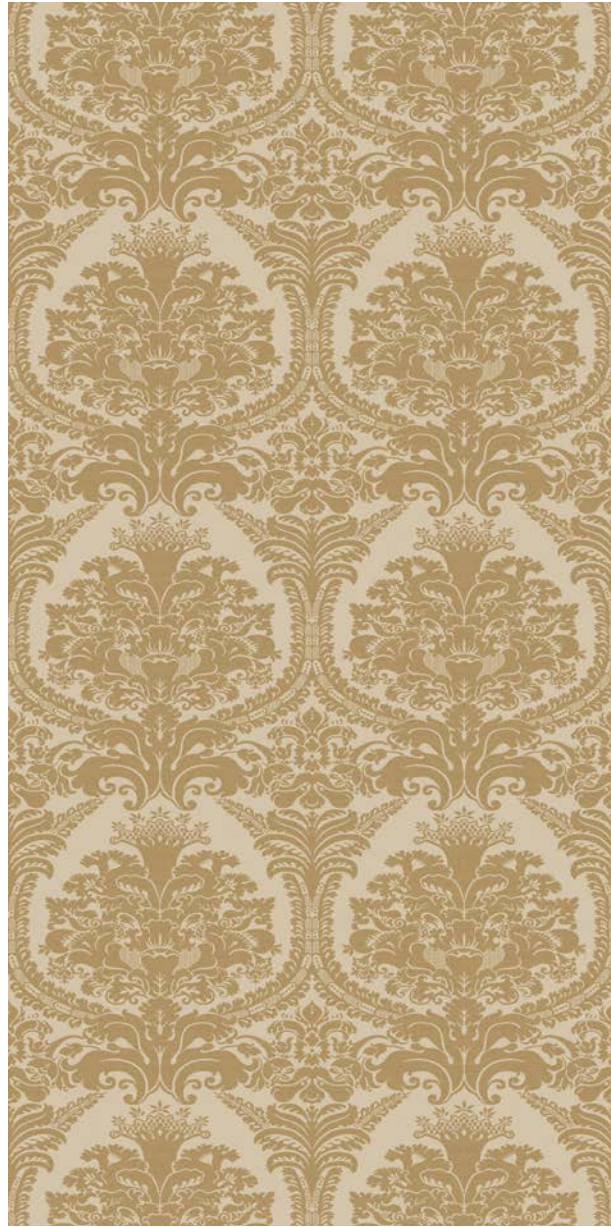

SAN MARCO AMBRA



6 mm 1/4" ↑
FLORIM OVERSIZE
magnUm

GRES PORCELLANATO DECORATO

DECORATED PORCELAIN TILES/GRÈS CÉRAME DÉCORÉ/VERZIERTES FEINSTEINZEUG/GRES PORCELÁNICO DECORADO
SQUADRATO - SQUARED - EQUARRI - REKTIFIZIERT - ESCUADRADO

6 mm 1/4" ↑	COLOR	SURFACE	120x280 47 ^{1/4"} x110 ^{1/4"}	120x240 47 ^{1/4"} x94 ^{1/2"}	60x120 A 23 ^{5/8"} x47 ^{1/4"}	60x120 B 23 ^{5/8"} x47 ^{1/4"}	60x120 C 23 ^{5/8"} x47 ^{1/4"}	60x120 D 23 ^{5/8"} x47 ^{1/4"}	60x120 23 ^{5/8"} x47 ^{1/4"} A+B+C+D
	SAN MARCO AVORIO ANTICO	MATTE	767060 ■ FL-42900	767095 ■ FL-42900	767132 ■ FL-39700	769094 ■ FL-39700	769095 ■ FL-39700	769096 ■ FL-39700	9000221 ■ FL-39700
	SAN MARCO AMBRA	MATTE	767061 ■ FL-42900	767096 ■ FL-42900	767133 ■ FL-39700	769139 ■ FL-39700	769140 ■ FL-39700	769141 ■ FL-39700	9000223 ■ FL-39700

RUBELLI
design

SAN MARCO GRANATA

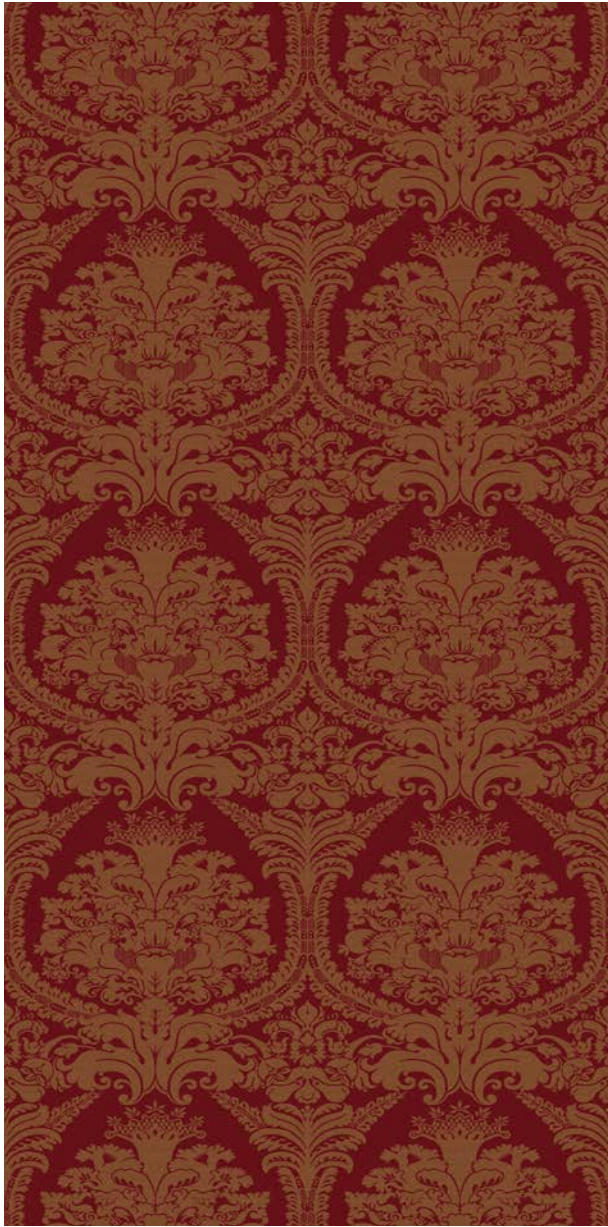



SAN MARCO BLU DI PRUSSIA



6 mm 1/4" ↑
FLORM OVERSIZE
magnUm

GRES PORCELLANATO DECORATO

DECORATED PORCELAIN TILES/GRÉS CÉRAMÉ DÉCORÉ/VERZIERTES FEINSTEINZEUG/GRES PORCELÁNICO DECORADO
SQUADRATO - SQUARED - EQUARRI - REKTIFIZIERT - ESCUADRADO

			120x280 47 ^{11/16"} x110 ^{1/4"}	120x240 47 ^{11/16"} x94 ^{1/2"}	60x120 A 23 ^{5/8"} x47 ^{1/4"}	60x120 B 23 ^{5/8"} x47 ^{1/4"}	60x120 C 23 ^{5/8"} x47 ^{1/4"}	60x120 D 23 ^{5/8"} x47 ^{1/4"}	60x120 23 ^{5/8"} x47 ^{1/4"} A+B+C+D	
I FILATI		SAN MARCO GRANATA	MATTE	767062 ■ FL-42900	767097 ■ FL-42900	767134 ■ FL-39700	769182 ■ FL-39700	769183 ■ FL-39700	769184 ■ FL-39700	9000224 ■ FL-39700
		SAN MARCO BLU DI PRUSSIA	MATTE	767063 ■ FL-42900	767098 ■ FL-42900	767135 ■ FL-39700	769200 ■ FL-39700	769201 ■ FL-39700	769202 ■ FL-39700	9000222 ■ FL-39700

RUBELLI
design

I FILATI

VAGUE VANIGLIA



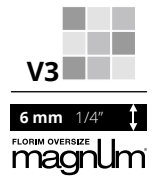

VAGUE CIPRIA



GRES PORCELLANATO DECORATO

DECORATED PORCELAIN TILES / GRÈS CÉRAMÉ DÉCORÉ / VERZIERTES FEINSTEINZEUG / GRES PORCELÁNICO DECORADO
SQUADRATO - SQUARED - EQUARRI - REKTIFIZIERT - ESCUADRADO

		6 mm 1/4" ↑↓								
		COLOR	SURFACE	120x280 47 ^{1/4"} x110 ^{1/4"}	120x240 47 ^{1/4"} x94 ^{1/2"}	60x120 A 23 ^{5/8"} x47 ^{1/4"}	60x120 B 23 ^{5/8"} x47 ^{1/4"}	60x120 C 23 ^{5/8"} x47 ^{1/4"}	60x120 D 23 ^{5/8"} x47 ^{1/4"}	60x120 23 ^{5/8"} x47 ^{1/4"} A+B+C+D
I FILATI		VAGUE VANIGLIA	MATTE	767071 ■ FL-42900	767106 ■ FL-42900	767143 ■ FL-39700	769130 ■ FL-39700	769131 ■ FL-39700	769132 ■ FL-39700	9000228 ■ FL-39700
		VAGUE CIPRIA	MATTE	767072 ■ FL-42900	767107 ■ FL-42900	767144 ■ FL-39700	769115 ■ FL-39700	769116 ■ FL-39700	769117 ■ FL-39700	9000230 ■ FL-39700

RUBELLI
design

VAGUE GIADA

VAGUE SCARLATTO

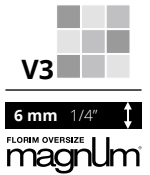
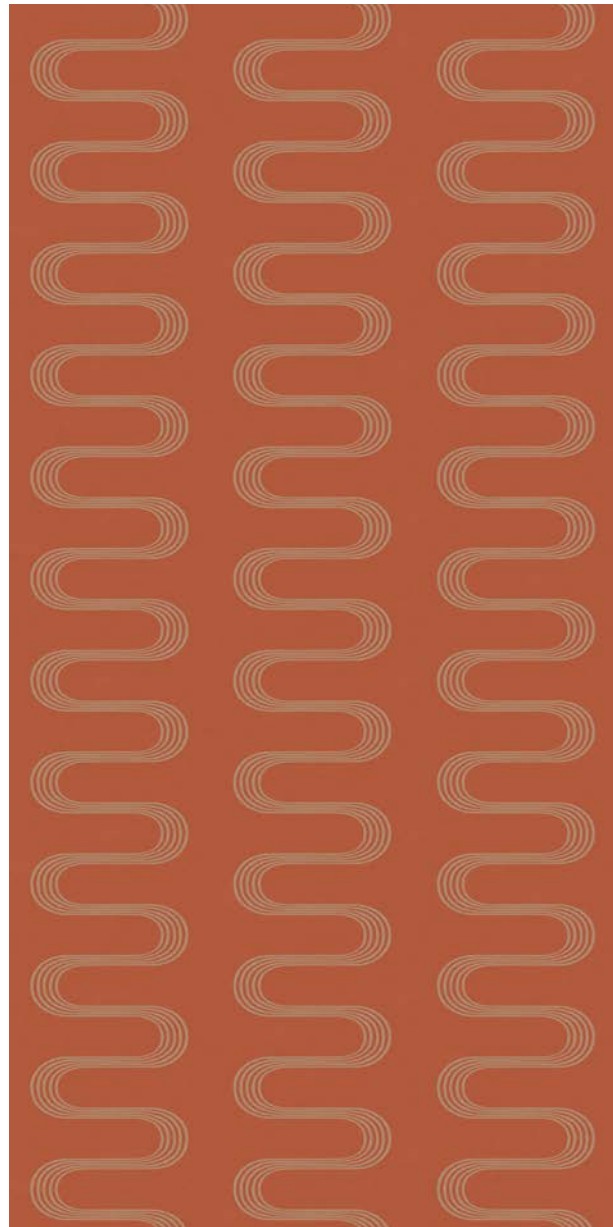
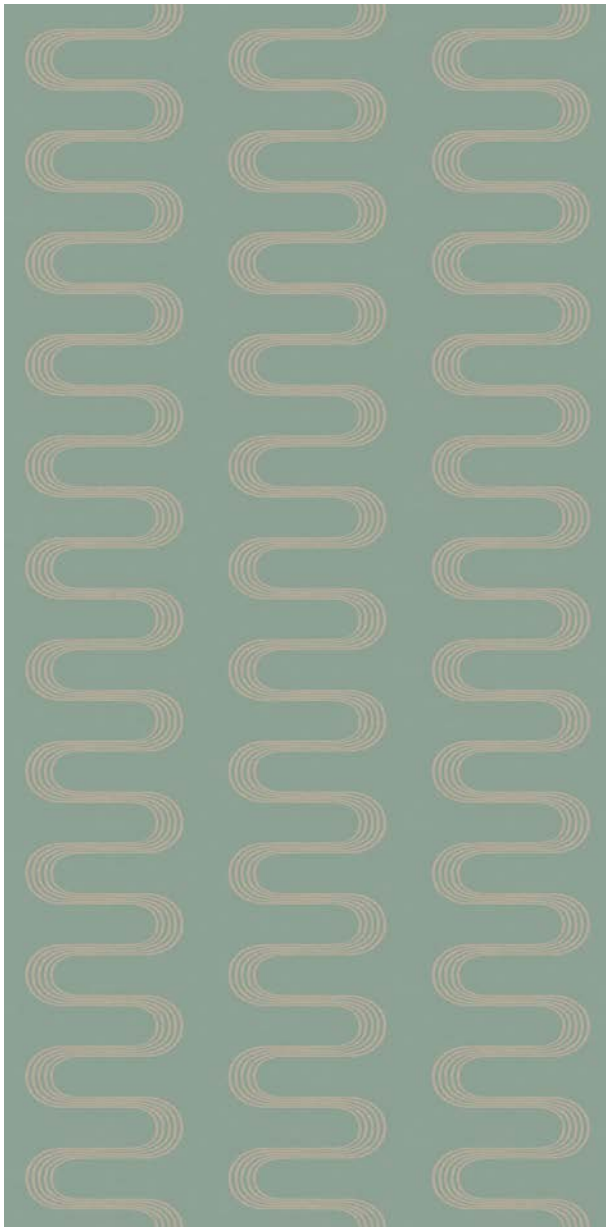

GRES PORCELLANATO DECORATO
 DECORATED PORCELAIN TILES/GRÉS CÉRAMÉ DÉCORÉ/VERZIERTES FEINSTEINZEUG/GRES PORCELÁNICO DECORADO
 SQUADRATO - SQUARED - EQUARRI - REKTIFIZIERT - ESCUADRADO

I FILATI	COLOR	SURFACE	120x280		120x240		60x120 A		60x120 B		60x120 C		60x120 D		60x120	
			47 ^{1/4"}	x110 ^{1/4"}	47 ^{1/4"}	x94 ^{1/2"}	23 ^{5/8"}	x47 ^{1/4"}	23 ^{5/8"}	x47 ^{1/4"}	23 ^{5/8"}	x47 ^{1/4"}	23 ^{5/8"}	x47 ^{1/4"}	23 ^{5/8"}	x47 ^{1/4"}
	VAGUE GIADA	MATTE	767073 ■ FL-42900	767108 ■ FL-42900	767145 ■ FL-39700	769145 ■ FL-39700	769146 ■ FL-39700	769147 ■ FL-39700	9000229 ■ FL-39700							
	VAGUE SCARLATTO	MATTE	767074 ■ FL-42900	767109 ■ FL-42900	767146 ■ FL-39700	769166 ■ FL-39700	769167 ■ FL-39700	769168 ■ FL-39700	9000231 ■ FL-39700							

I FILATI

HAPPY HOUR VANIGLIA

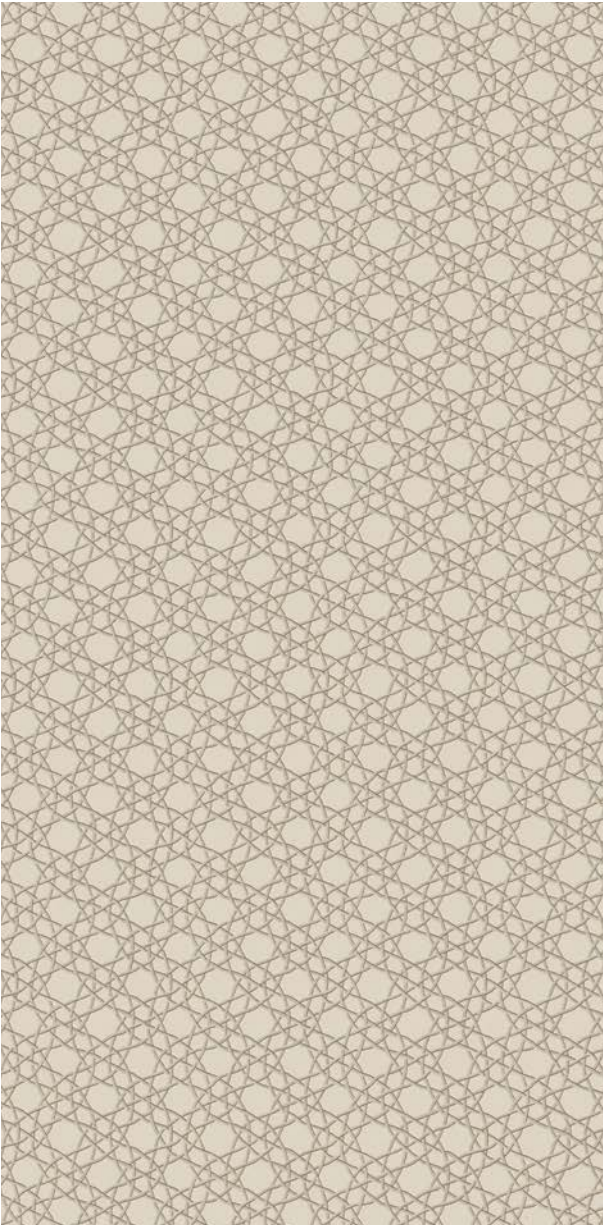

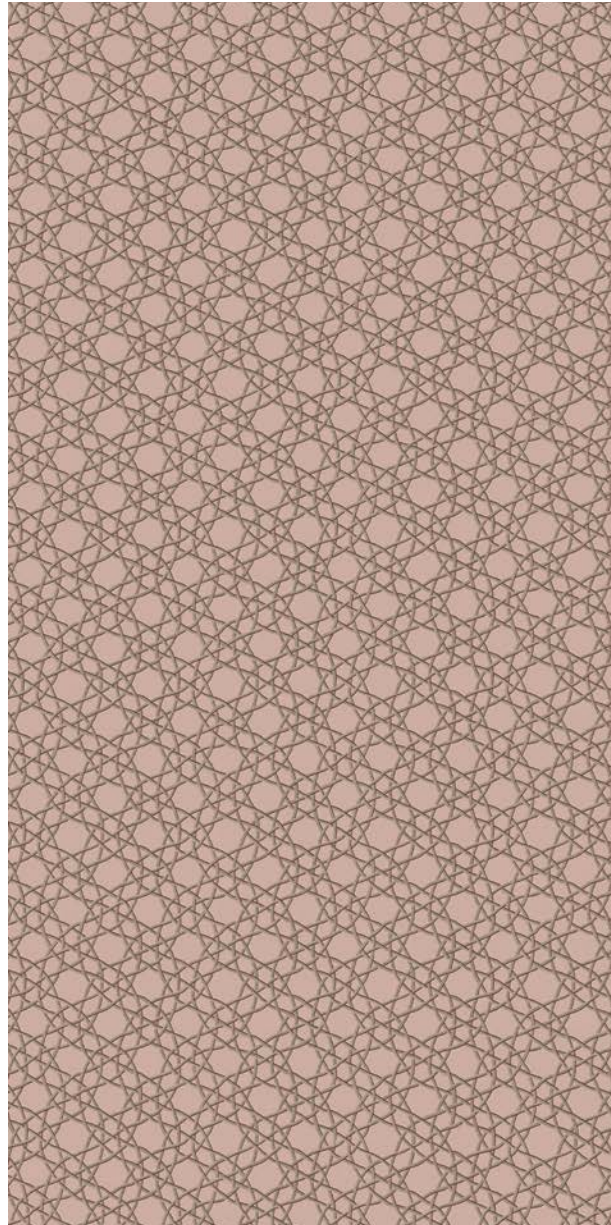

HAPPY HOUR CIPRIA



6 mm 1/4" ↑
FLORIM OVERSIZE
magnUm

GRES PORCELLANATO DECORATO

DECORATED PORCELAIN TILES/GRÈS CÉRAMÉ DÉCORÉ/VERZIERTES FEINSTEINZEUG/GRES PORCELÁNICO DECORADO
SQUADRATO - SQUARED - EQUARRI - REKTIFIZIERT - ESCUADRADO

6 mm 1/4" ↑	COLOR	SURFACE	120x280 47 ^{1/4"} x110 ^{1/4"}	120x240 47 ^{1/4"} x94 ^{1/2"}	60x120 A 23 ^{5/8"} x47 ^{1/4"}	60x120 B 23 ^{5/8"} x47 ^{1/4"}	60x120 C 23 ^{5/8"} x47 ^{1/4"}	60x120 D 23 ^{5/8"} x47 ^{1/4"}	60x120 23 ^{5/8"} x47 ^{1/4"} A+B+C+D
	HAPPY HOUR VANIGLIA	MATTE	767213 ■ FL-42900	767217 ■ FL-42900	767221 ■ FL-39700	769121 ■ FL-39700	769122 ■ FL-39700	769123 ■ FL-39700	9000232 ■ FL-39700
	HAPPY HOUR CIPRIA	MATTE	767214 ■ FL-42900	767218 ■ FL-42900	767222 ■ FL-39700	769106 ■ FL-39700	769107 ■ FL-39700	769108 ■ FL-39700	9000234 ■ FL-39700

RUBELLI
design

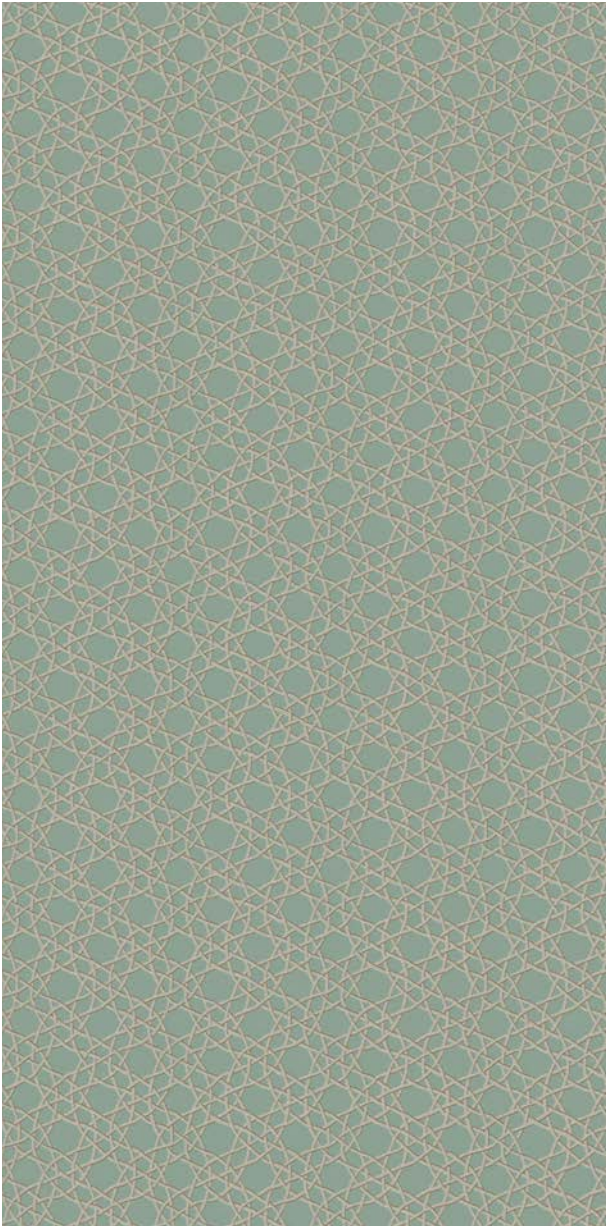

HAPPY HOUR GIADA

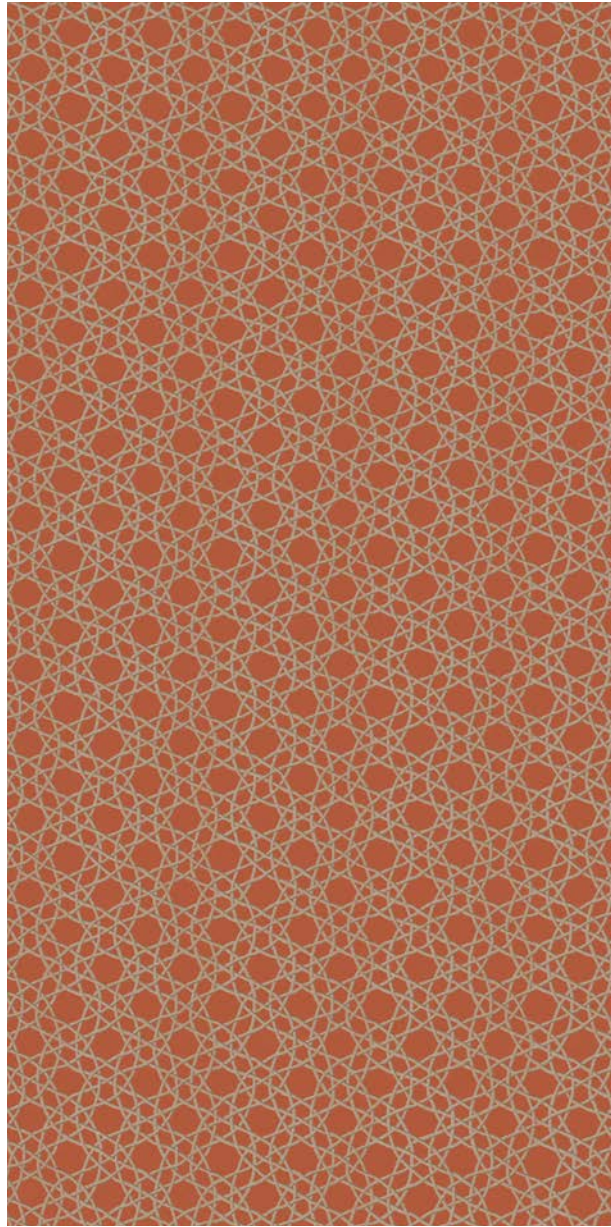

HAPPY HOUR SCARLATTO



GRES PORCELLANATO DECORATO
 DECORATED PORCELAIN TILES/GRÉS CÉRAMÉ DÉCORÉ/VERZIERTES FEINSTEINZEUG/GRES PORCELÁNICO DECORADO
 SQUADRATO - SQUARED - EQUARRI - REKTIFIZIERT - ESCUADRADO

6 mm 1/4" ↑↓		COLOR	SURFACE	120x280 47 ^{1/4"} x110 ^{1/4"}	120x240 47 ^{1/4"} x94 ^{1/2"}	60x120 A 23 ^{5/8"} x47 ^{1/4"}	60x120 B 23 ^{5/8"} x47 ^{1/4"}	60x120 C 23 ^{5/8"} x47 ^{1/4"}	60x120 D 23 ^{5/8"} x47 ^{1/4"}	60x120 23 ^{5/8"} x47 ^{1/4"} A+B+C+D
I FILATI		HAPPY HOUR GIADA	MATTE	767215 ■ FL-42900	767219 ■ FL-42900	767223 ■ FL-39700	769142 ■ FL-39700	769143 ■ FL-39700	769144 ■ FL-39700	9000233 ■ FL-39700
		HAPPY HOUR SCARLATTO	MATTE	767216 ■ FL-42900	767220 ■ FL-42900	767224 ■ FL-39700	769163 ■ FL-39700	769164 ■ FL-39700	769165 ■ FL-39700	9000235 ■ FL-39700

I FILATI

OP ART VANIGLIA

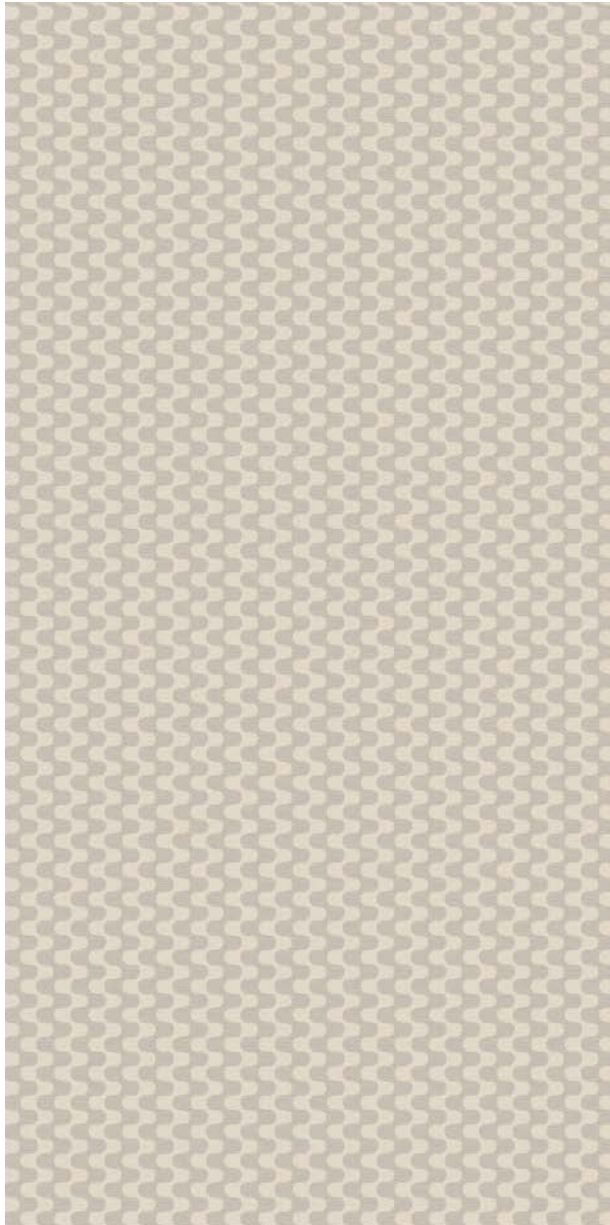

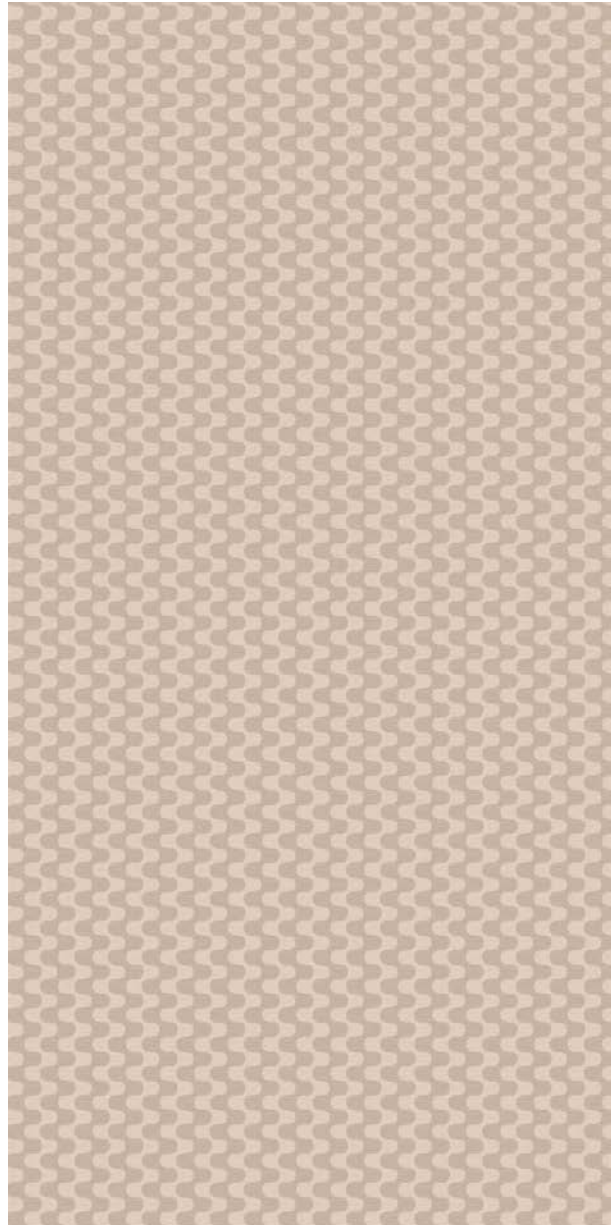

OP ART CIPRIA



6 mm 1/4" ↑↓
FLORIM OVERSIZE
magnUm

GRES PORCELLANATO DECORATO

DECORATED PORCELAIN TILES/GRÈS CÉRAME DÉCORÉ/VERZIERTES FEINSTEINZEUG/GRES PORCELÁNICO DECORADO
SQUADRATO - SQUARED - EQUARRI - REKTIFIZIERT - ESCUADRADO

6 mm 1/4" ↑↓		COLOR	SURFACE	120x280 47 ^{1/4"} x110 ^{1/4"}	120x240 47 ^{1/4"} x94 ^{1/2"}	60x120 A 23 ^{5/8"} x47 ^{1/4"}	60x120 B 23 ^{5/8"} x47 ^{1/4"}	60x120 C 23 ^{5/8"} x47 ^{1/4"}	60x120 D 23 ^{5/8"} x47 ^{1/4"}	60x120 23 ^{5/8"} x47 ^{1/4"} A+B+C+D
I FILATI		OP ART VANIGLIA	MATTE	767068 ■ FL-42900	767103 ■ FL-42900	767140 ■ FL-39700	769127 ■ FL-39700	769128 ■ FL-39700	769129 ■ FL-39700	9000225 ■ FL-39700
		OP ART CIPRIA	MATTE	767069 ■ FL-42900	767104 ■ FL-42900	767141 ■ FL-39700	769112 ■ FL-39700	769113 ■ FL-39700	769114 ■ FL-39700	9000226 ■ FL-39700

RUBELLI
design

OP ART TÈ VERDE

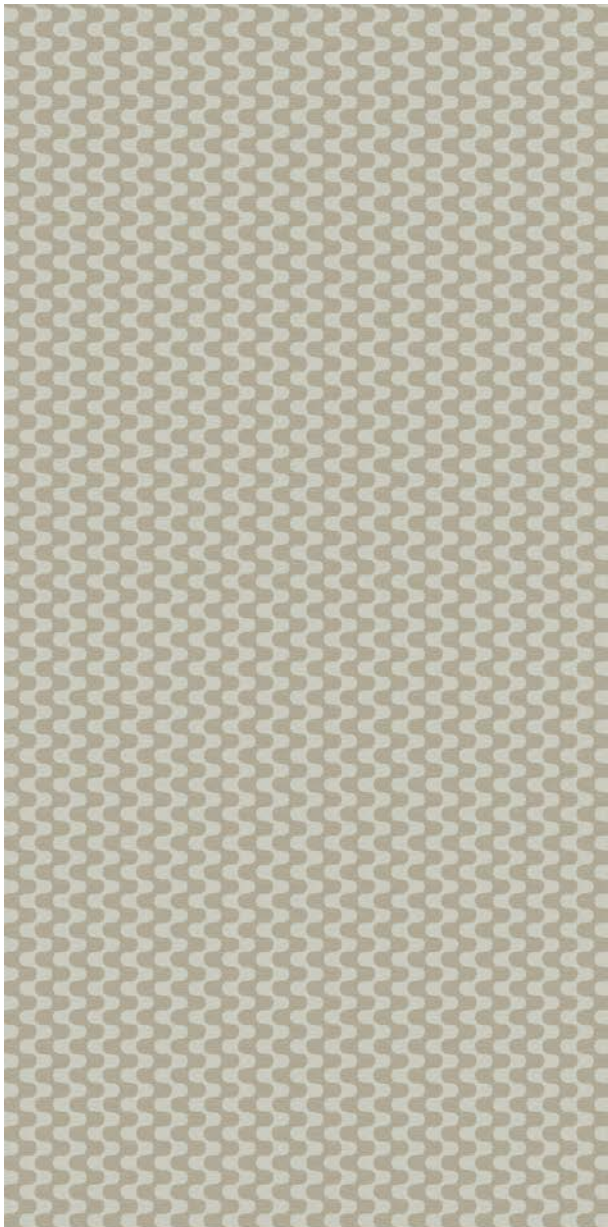

GRES PORCELLANATO DECORATO
 DECORATED PORCELAIN TILES/GRÈS CÉRAMÉ DÉCORÉ/VERZIERTES FEINSTEINZEUG/GRES PORCELÁNICO DECORADO
 SQUADRATO - SQUARED - EQUARRI - REKTIFIZIERT - ESCUADRADO

6 mm 1/4" ↑↓	COLOR	SURFACE	120x280 47 ^{1/4"} x110 ^{1/4"}	120x240 47 ^{1/4"} x94 ^{1/2"}	60x120 A 23 ^{5/8"} x47 ^{1/4"}	60x120 B 23 ^{5/8"} x47 ^{1/4"}	60x120 C 23 ^{5/8"} x47 ^{1/4"}	60x120 D 23 ^{5/8"} x47 ^{1/4"}	60x120 23 ^{5/8"} x47 ^{1/4"} A+B+C+D
I FILATI	 OP ART TÈ VERDE	MATTE	767070 ■ FL-42900	767105 ■ FL-42900	767142 ■ FL-39700	769148 ■ FL-39700	769149 ■ FL-39700	769150 ■ FL-39700	9000227 ■ FL-39700

RUBELLI
design

FLOHM OVERSIZE
magnUm

120x280/120x240
 Specifica Imballo pag.
 Packaging specifications on page
 Spécifications d'emballage à page
 Verpackungsdetail Seite
 Especificaciones de embalaje a la página
204/205

I FILATI	scatola - box			pallet		
	pz	mq	kg	box	mq	kg
60x120	2	1,44	20,85	20	28,80	440

I FILATI

Lady Hamilton cipria A+B+C+D

60x120 (23^{5/8}"x 47^{1/4}")

cod 9000204



A
60x120
cod.767113

B
60x120
cod.769109

C
60x120
cod.769110

D
60x120
cod.769111

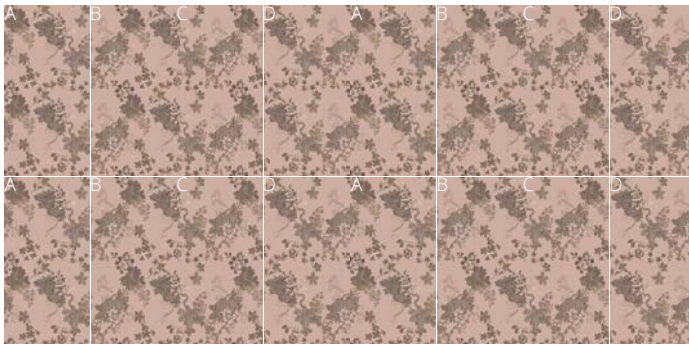

posa verticale
vertical installation

Lady Hamilton amaranto A+B+C+D

60x120 (23^{5/8}"x 47^{1/4}")

cod 9000205



A
60x120
cod.767115

B
60x120
cod.769160

C
60x120
cod.769161

D
60x120
cod.769162

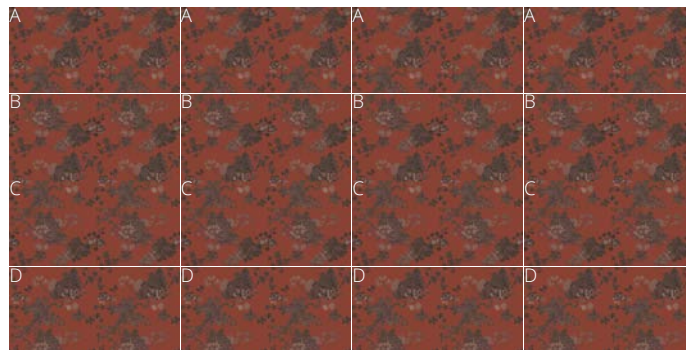

posa orizzontale
horizontal installation

Ordinando il codice es 9000204 il cliente riceverà 4 scatole, ogni scatola contiene 2 pz delle grafiche A / B / C / D. - By ordering code (for example 9000204) the customer will receive 4 boxes, each box contains 2 pcs of the designs A/B/C/D. - En commandant le code (par exemple 9000204) le client recevra 4 boites, chaque boite contiendra 2 pcs des motifs A / B / C / D. - Bei Bestellung des Codes (z.B. 9000204) erhält der Kunde 4 Kartons, jeder Karton enthält 2 Stück der Grafiken A / B / C / D. - Al pedir el código (por ejemplo, 9000204), el cliente recibirá 4 cajas, cada caja contendrá 2 piezas de cada uno de los gráficos A / B / C / D.

Ordinando il codice es 767113 il cliente riceverà una scatola contenente 2 pezzi della grafica A - By ordering code (for example 767113) the customer will receive 2 pcs of the design A. - En commandant le code (par exemple 767113) le client recevra 1 boite, qui contiendra 2 pièces du motif A. - Mit der Bestellung des Codes (z.B. 767113) erhält der Kunde eine Schachtel mit 2 Grafiken A. - Al pedir el código (por ejemplo, 767113), el cliente recibirá una caja que contendrá 2 piezas del gráfico A.

I FILATI nel formato 60x120 identificati dai codici 9000 ABCD compongono il disegno nel formato 120x240, nel caso di danneggiamento di uno dei 4 pezzi si possono ordinare separatamente facendo riferimento al numero seriale seguito dalla lettera. / I FILATI size 60x120 identified by item codes 9000 ABCD compose the design in size 120x240; should one of the elements be damaged, they can be ordered separately making reference to the serial number followed by the letter. / I FILATI identifiés pour le format 60x120 avec les codes 9000 ABCD composent ensemble le dessin dans le format 120x240; en cas d'endommagement d'une des 4 plaques, elle peuvent être commandées séparément en se référant au numéro de série suivi de la lettre. / Filati im 60x120-Format, die durch die 9000 ABCD-Codes gekennzeichnet sind, bilden das Bild im 120x240-Format. Wenn eines der 4 Teile beschädigt ist, kann es unter Bezugnahme auf die Seriennummer gefolgt vom Buchstaben separat bestellt werden. / FILATI en el formato 60x120 identificado por los códigos 9000 ABCD conforman el diseño en el formato 120x240; Si una de las 4 piezas está dañada, se puede pedir por separado haciendo referencia al número de serie seguido de la letra.

Ogni soggetto è caratterizzato da una decorazione che continua da pezzo a pezzo considerando 1mm di fuga. Prima di passare alla fase di posa stendere i vari soggetti a terra per verificarne la continuità del prodotto. / Each panel features a pattern that continues from piece to piece with a 1 mm joint. Before laying, spread the various panels on the ground to check the pattern's continuity. / Chaque sujet se caractérise par une décoration qui continue d'une pièce à l'autre, en tenant compte de 1 mm de joint. Avant de passer à la phase de pose, étaler les différents sujets au sol, pour en vérifier la continuité de la décoration. / Jedes Muster ist von einem Dekor charakterisiert, das von Platte zu Platte weiterverläuft, wenn man von der 1 mm Fuge absieht. Sollte vor dem Verlegen die einzelnen Muster auf den Boden angeordnet werden, um die Kontinuität des Dekors zu prüfen. / Cada pieza se caracteriza por una decoración que continúa de una a otra con una fuga de 1 mm. Antes de pasar a la fase de colocación extender los diferentes motivos sobre el suelo para comprobar la continuidad de la decoración.

GRES PORCELLANATO DECORATO

DECORATED PORCELAIN TILES/GRÉS CÉRAMÉ DÉCORÉ/VERZIERTES FEINSTEINZEUG/GRES PORCELÁNICO DECORADO

AVVERTENZE / WARNINGS / AVERTISSEMENTS / HINWEISE / ADVERTENCIAS

<p>INDICAZIONI GENERALI GENERAL INSTRUCTIONS INDICATIONS GÉNÉRALES ALLGEMEINE HINWEISE INDICATIONS GÉNÉRALES</p>	<p>Florim indica di stoccare il materiale in magazzini coperti o al riparo da agenti atmosferici, coprendo il materiale con cappucci protettivi. È NECESSARIO EVITARE OGNI TIPO DI STROFINAMENTO O TRAUMA SUPERFICIALE DELLA LASTRA DURANTE TUTTE LE FASI DI MOVIMENTAZIONE POSA E STUCCATURA. I prodotti in gres porcellanato decorato sono realizzati con una tecnologia produttiva differente dai prodotti in gres porcellanato tradizionale. Nel caso in cui si intenda posare le due tipologie di materiale nello stesso ambiente si potrebbero verificare differenze di aspetto superficiale e "punto di colore". / Florim recommends storing the material in indoor warehouses or protected from the weather, covered with protective hoods. CARE MUST BE TAKEN TO PREVENT ANY RUBBING OF OR KNOCKS ON THE SURFACE OF THE SLAB THROUGHOUT ALL HANDLING, INSTALLATION AND GROUTING PHASES. The decorated porcelain stoneware products are made with a production technology which differs from traditional porcelain stoneware production. If you plan to install the two types of material in the same area, there could be differences in surface appearance and "color point". / Florim précise de stocker le matériel dans des entrepôts couverts et à l'abri des intempéries, en le recouvrant d'une protection. Le gres porcellanato décoré est différent des produits en gres porcellanato traditionnels. DURING ALL STAGES OF THE LAYING AND EXECUTION PHASES, IT IS IMPORTANT TO PROTECT THE SURFACE OF THE SLABS AGAINST ALL TYPES OF FROTTING AND CHOCOS. À TOUTES LES ÉTAPES DE LA POSE, DE LA MANUTENTION ET DE L'EXECUTION DES JOINTS, LES PRODUITS EN GRÉS CÉRAMÉ DÉCORÉS SONT FAIRIQUÉS À L'AIDE D'UNE TECHNOLOGIE DE PRODUCTION DIFFÉRENTE DES PRODUITS EN GRÉS CÉRAMÉ TRADITIONNELS. Si vous avez l'intention de poser les deux types de matériaux dans la même pièce, il pourrait y avoir des différences d'aspect de surface et de "point de couleur". / Florim empfiehlt, das Material in geschlossenen Lagern bzw. vor Witterung geschützt aufzubewahren und mit Schutzplanen abzudecken. BEI HANDLING, VERLEGUNG UND VERKÜGUNG SIND REIBEKONTAKTE UND VERLETZUNGEN DER OBERFLÄCHE ZU VERMEIDEN. Die dekorierten Feinsteinzeugprodukte werden mit einer anderen Produktionstechnologie hergestellt, als die traditionellen Feinsteinzeugprodukte. Wenn Sie die beiden Materialarten in derselben Umgebung verlegen möchten, kann es zu Unterschieden in der Oberflächengestaltung und Farbton kommen. / Florim indica que el material debe guardarse, tapado con capuchas de protección, en almacenes cubiertos o al amparo de los agentes atmosféricos. DURANTE TODAS LAS FASES DE DESPLAZAMIENTO, COLOCACION Y REJUNTADO EVITESE CAUSAR CUALQUIER TIPO DE ROZAMIENTO O DE TRAUMA SOBRE LA SUPERFICIE DE LA PLACA. Los productos de gres porcelánico decorado se elaboran con una tecnología de producción diferente a los productos tradicionales de gres porcelánico. En el caso tal que se requiera colocar los dos tipos de material en el mismo entorno, pueden haber diferencias en la apariencia de la superficie y el "punto de color".</p>
<p>DESTINAZIONE D'USO RECOMMENDED APPLICATIONS DOMAINE D'APPLICATION ANWENDUNGSBEREICHE USO PREVISTO</p>	<p>Lastre decorate con innovative tecniche artigianali destinate esclusivamente al rivestimento di pareti interne. Eventuali piccole imperfezioni sono da considerarsi caratteristiche proprie del prodotto dovute al processo produttivo. Questa innovativa tecnica decorativa migliora la definizione e la profondità dei colori, rendendo la resistenza superficiale all'abrasione meno performante rispetto al gres porcellanato tradizionale. Per questo motivo è necessario attenersi alle istruzioni riportate negli imballi (qualora non fossero presenti), è possibile consultare il sito internet). Il materiale è utilizzabile anche come rivestimento della parete della doccia. In questa destinazione d'uso, per la corretta posa in opera, Florim raccomanda di installare solo lastre intere o posizionare i tagli della lastra non a contatto con il piatto doccia. In caso di utilizzo come backplash, Florim richiede l'installazione delle lastre a una distanza minima di 20 cm dai fuochi del piano cottura. Si consiglia l'utilizzo del materiale come rivestimento di camini,stufe e, più in generale, la posa in prossimità di fonti di calore. / Slabs decorated by innovative hand techniques intended only for covering interior walls. Any minor flaws are an intrinsic characteristic of the product, due to the production process. This innovative decorative technique improves the definition and depth of the colours but reduces resistance to surface abrasion compared to standard porcelain stoneware. The instructions provided inside the packaging must therefore be complied with (if not found, refer to the website). The material can also be used to cover the walls of showers. For this intended use, for correct installation, Florim advises you to install whole slabs only, or to ensure that cut edges of slabs are not in contact with the shower tray. In case of use as a backplash, Florim specifies that slabs must be installed at least 20 cm from hob burners. The material is not recommended for use for covering fireplaces or stoves, or for installation close to heat sources in general. / Dalles décorées par des techniques artisanales modernes, à utiliser exclusivement pour le revêtement des murs intérieurs. Les petites imperfections de surface des dalles sont à considérer comme des caractéristiques propres du produit dues au processus de production. Cette technique de décoration optimise la définition et la profondeur des couleurs, mais donne à la surface une résistance à l'abrasion inférieure par rapport au gres céramé traditionnel. Pour cette raison, les instructions contenues dans les emballages doivent être suivies à la lettre (si la boîte ne les contient pas, il est possible de consulter le site internet). Le produit peut être pose sur le mur de la douche. Dans ce cas, pour un bon résultat de pose, Florim conseille d'installer uniquement des dalles entières ou de ne pas mettre les découpes de la dalle en contact avec le receveur. Si les dalles sont posées en dossier, Florim préconise de ne pas les placer à moins de 20 cm des feux de la table de cuisson. Il est déconseillé d'utiliser le produit pour revêtir des cheminées, des poêles et, de manière plus générale, de le poser à proximité de sources de chaleur. / Dekorierte Platten, hergestellt mit modernen Handwerkstechniken, ausschließlich für die Wandverkleidung im Innenbereich. Etwas geringfügige Unregelmäßigkeiten sind keine Mängel, sondern ein typisches, verfahrenstechnisch bedingtes Produktmerkmal. Dieses innovative Dekorationsverfahren verbessert die Farbdefinition und -tiefe bei gleichzeitig verringerter Abriebbeständigkeit gegenüber herkömmlichem Feinsteinzeug. Aus diesem Grund beachten Sie bitte genau die beigelegte Anleitung (sollten diese nicht vorhanden sein, informieren Sie sich bitte auf der Website). Das Material kann auch für die Wandverkleidung von Duschnischen verwendet werden. In diesem Fall empfiehlt Florim, nur ganze Platten zu verlegen bzw. die Schnittflächen der Platte nicht im Kontakt mit der Duschwanne zu verlegen. Bei Verwendung für Fliesenpiegel soll der Abstand der Platten von den Herdstellen des Kochfeldes mindestens 20 cm betragen. Die Verwendung der Platten für die Verkleidung von Kaminen und Öfen bzw. die Verwendung in der Nähe von Wärmequellen wird nicht empfohlen. / Placas decoradas con innovadoras técnicas artesanales destinadas exclusivamente al revestimiento de paredes interiores. Eventuales pequeñas imperfecciones de superficie son características propias del producto debidas al proceso de fabricación. Esta innovadora técnica decorativa mejora la definición y la profundidad de los colores, pero hace que la resistencia superficial a la abrasión sea menor con respecto a la que presenta el gres porcelánico tradicional. Por este motivo hay que atenderse a las instrucciones que se encuentran en los embalajes (si no las hay, siempre pueden consultarse en el sitio web). El material también se puede utilizar para revestir la pared de la ducha. En el caso de este tipo de aplicación, para una correcta colocación, Florim recomienda instalar únicamente placas enteras o situar los recortes de placas donde no entren en contacto con el plato de la ducha. En caso de uso como salpicadero, Florim exige la colocación de las placas a una distancia mínima de 20 cm de los fogones de la superficie de cocción. Se desaconseja el empleo de este material para revestir chimeneas, estufas y, más en general, superficies cercanas a fuentes de calor.</p>
<p>MOVIMENTAZIONE HANDLING MANUTENTION TRANSPORT UND HANDHABUNG DESPLAZAMIENTO</p>	<p>Nella movimentazione evitare il contatto con materiali abrasivi e lo strofinamento con altre lastre o con il piano di lavoro. Non appoggiare sulla superficie utensili o altro materiale che potrebbe danneggiare il prodotto. Si consiglia di movimentare le lastre utilizzando appositi telai a ventosa, assicurandosi che le ventose siano perfettamente pulite e avendo cura di: -utilizzare ventose dotate di vacuometro per valutare/verificare la corretta e costante adesione delle ventose stesse alla lastra (per movimentare lastre lucide è possibile mantenere la pellicola); - definire il numero di operatori addetti alla fase di movimentazione sulla base del peso totale (lastra più telaio) da sollevare e di eventuali limiti imposti da norme antinfortunistiche. - ridurre al minimo (pochi metri) il tragitto di movimentazione manuale con ventosa. / When handling, avoid contact with abrasive materials or rubbing against other slabs or the work surface. Do not place tools or any other material which might damage the product on the surface. Special suction cup frames should be used when handling slabs, making sure that the suction cups are perfectly clean and always - using suction cups with vacuum meter, for measuring/checking correct, constant adhesion between the suction cups and the slab (when handling glossy slabs, the film can be left in place); - deciding the number of workers to be assigned to handling operations on the basis of the total weight (slab plus frame) to be lifted and any limits set by safety regulations; - minimising (to just a few metres) the distance over which slabs are carried by hand with suction cup. / Pendant la manutention, éviter tout contact avec les matériaux abrasifs et tout frotement avec d'autres dalles ou avec le plan de travail. Ne pas poser sur la surface des outils ou autre matériel qui pourrait endommager le produit. Il est recommandé d'utiliser les araignées à ventouses pour manutentionner les dalles en s'assurant que les ventouses sont parfaitement propres et en veillant à: - utiliser des ventouses avec vacuomètre pour évaluer/vérifier la bonne adhérence des ventouses à la dalle (pour manutentionner les dalles brillantes, le film de protection peut être laissé); - définir le nombre d'opérateurs nécessaires à la manutention selon le poids total (dalle + araignée) à soulever et selon les éventuelles restrictions imposées par les normes relatives à la prévention des accidents. - réduire au minimum (quelques mètres) le parcours de manutention manuelle avec ventouse. / Bei der Handhabung sind der Kontakt mit scheuernden Materialien und der Reibekontakt mit anderen Platten oder der Werkbank zu vermeiden. Werkzeuge oder anderweitige Gegenstände, die das Produkt beschädigen könnten, dürfen nicht auf der Oberfläche abgelegt werden. Es wird empfohlen, für das Tragen und Heben der Platten einen Heberahmen mit Saugtellern zu verwenden. Hierbei ist sicherzustellen, dass die Saugteller vollkommen sauber sind, und ist auf folgende charakteristische Punkte zu achten: - Die Saugteller sollen mit einem Vakuummeter ausgestattet sein, um ihre sichere und konstante Haftung an der Platte beurteilen/kontrollieren zu können (für das Handling von glänzenden Platten kann die Schutzfolie an Ort und Stelle verbleiben); - Die Anzahl der Mitarbeiter für das Handling auf der Grundlage des Gesamtgewichtes (Platte plus Heberahmen) und etwaiger Sicherheitsvorgaben zum Unfallschutz bestimmen; - Der Transportweg für das manuelle Handling der Platte ist auf ein Mindestmaß (wenige Meter) zu reduzieren; - Ein der Desplazamiento evite el contacto con materiales abrasivos y el roce con otras placas o con la superficie de trabajo. No depositar sobre la superficie herramientas ni ningún material que pueda dañar el producto. Se aconseja desplazar las placas utilizando bastidores dotados de ventosas, cerciorándose previamente de que estas estén perfectamente limpias y procurando: - utilizar ventosas provistas de un vacuómetro para evaluar/verificar la correcta y constante adhesión de las mismas a la placa (en caso de desplazar placas brillantes es posible mantener la película de protección); - establecer el número de operarios que van a encargarse del desplazamiento en función del peso total (placa más bastidor) que haya de levantarse y de las posibles limitaciones que las normas de prevención de accidentes impongan; - reducir al mínimo (a unos pocos metros) el trayecto de desplazamiento manual con ventosa.</p>
<p>TAGLIO/FORO CUTTING/DRILLING DÉCOUPE/TROU SCHNEIDEN/BOHREN CORTE/ORIFICIO</p>	<p>Verificare che il piano di appoggio sia perfettamente stabile, pianare, pulito e privo di ogni asperità che possa danneggiare il materiale; è possibile usare come protezione della superficie, quando necessario, il foglio "protettivo/distanziatore" contenuto nell'imballaggio. Come tagliare le lastre delle diverse collezioni: 1 Filati: incidere il retro della lastra utilizzando appositi strumenti da taglio per lastre avendo cura di rimuovere, prima del taglio, la pellicola protettiva, quando presente. / Check that the supporting surface is perfectly stable, flat and clean and does not have any rough areas which may damage the material. The "protective/spacer" sheet provided in the packaging can be used to protect the surface when necessary. How to cut slabs from the various collections: 1 filati : cut into the back of the slab using suitable slab cutting tools, taking care to remove any protective film before cutting. / S'assurer que la surface d'appui est parfaitement stable, plane, propre et sans irrégularités susceptibles d'endommager le produit. Il est possible d'utiliser la feuille de protection/d'espacement contenue dans l'emballage pour protéger la surface, si nécessaire. Comment découper les dalles des différentes collections: 1 filati : faire une amorce au dos de la dalle en utilisant les outils de coupe pour dalles en veillant à retirer, avant la coupe, l'éventuel film de protection. / Kontrollieren, dass die Arbeitsunterlage vollkommen stabil, plan und sauber ist und keine Unebenheiten aufweist, die zu Beschädigungen der Platte führen könnten. Für den Oberflächenschutz kann bei Bedarf die in der Verpackung enthaltene Schutz- bzw. Zwischenlagefolie verwendet werden. Platten schneiden: 1 Filati: Die Platten rückseitig unter Verwendung von Plattenschneidwerkzeugen ansetzen, nachdem die Schutzfolie, sofern vorhanden, entfernt wurde. / Comprobar que la superficie sobre la que depositamos las placas sea estable, plana, esté perfectamente limpia y carezca de asperezas que puedan dañar el material; cuando sea necesario, para proteger la superficie, podrá usarse la hoja "protectora/distanziadora" que se encontrará en el embalaje. Como cortar las placas de las varias colecciones: 1 filati: practicar una incisión en la parte posterior de la placa sirviéndose de oportunas herramientas de corte para placas; antes de proceder al corte retirar la película de protección, si la hay.</p>
<p>POSA INSTALLATION POSE VERLEGEN COLOCACION</p>	<p>Si consiglia l'uso di distanziatori livellanti tradizionali. È possibile utilizzare i livellanti a vite dotati di guarnizione protettiva (che deve essere assolutamente pulita per evitare di rovinare/segnare la lastra). / The use of standard levelling spacers is not recommended. Screw levelling spacers with protective gasket (which must be absolutely clean to avoid damaging/marking the slab) may be used. / Il est déconseillé d'utiliser les croisillons nivelants traditionnels. Il est possible d'utiliser les croisillons à vis avec joint de protection (qui doit être absolument propre pour éviter d'abîmer/de marquer la dalle). / Die Verwendung von herkömmlichen Verlegethilfen wird nicht empfohlen. Es können Verlegethilfen mit Schraubsystem verwendet werden, die mit einer Schutzdichtung ausgestattet sind (diese muss vollkommen sauber sein, damit keine Beschädigungen/Kratzer an der Platte entstehen). Se desaconseja el uso de separadores de nivelación tradicionales. Se pueden utilizar separadores de nivelación de tornillo dotados de guarnición de protección (que ha de estar perfectamente limpia para evitar estropear/arañar la placa).</p>
<p>STUCCATURA GROUTING RÉALISATION DES JOINTS VERLEGEN REJUNTADO</p>	<p>Si consiglia l'uso di soli sigillanti cementizi a grana fine e spatole in materiale plastico. Si consiglia l'uso di silicone acetico come sigillante. (Attenzione: la pellicola, quando presente, non deve impedire il corretto e completo riempimento della fuga). Proteggere con scotch di carta la superficie prima della sigillatura. 1 Filati: applicare il sigillante con spatola di gomma. / Only fine-grain cement grouts and plastic trowels should be used. The use of acetoxy silicone as a grout is not recommended. (Important: any film present must not prevent correct, complete filling of the joint). Protect the surface with masking tape before grouting. 1 Filati: apply the grout with a rubber trowel. / Il est recommandé d'utiliser uniquement des mortiers-ciments à grains fins et des spatules en plastique. Il est déconseillé d'utiliser un silicone acétique pour l'exécution des joints. (Attention: le film de protection, si présent, ne doit pas entraver le remplissage complet du joint). Avant de faire les joints, protéger la surface avec un ruban papier adhésif. Filati: appliquer le mortier avec une spatule en caoutchouc. / Für die Verfugung empfehlen wir, ausschließlich feinkörnigen zementären Fugenmortel und einen Gummischaber zu verwenden. Die Verwendung von Acetatsilikon wird nicht empfohlen. (Achtung: Sofern vorhanden, darf die Schutzfolie nicht die korrekte und vollständige Ausfüllung der Fuge behindern). Die Plattenoberfläche vor dem Verfugen mit Papierklebeband abkleben. Filati: Fugenmörtel mit Gummischaber auftragen. Se recomienda emplear exclusivamente selladores cementosos de grano fino y espátulas de plástico. Se desaconseja el uso de silicona acética para sellar. / 1 Filati: la película de protección, cuando la haya, no debe impedir el correcto y completo llenado de las juntas). Antes de sellar protéjase la superficie con cinta de papel. Filati: aplicar el sellador con la espátula de goma.</p>
<p>PULIZIA POST POSA POST-INSTALLATION CLEANING NETTOYAGE APRÈS POSE ERSTREINIGUNG LIMPIEZA TRAS LA COLOCACION</p>	<p>Avere cura di pulire i residui prima dell'indurimento dello stucco con acqua e spugna non abrasiva evitando di danneggiare la superficie della lastra. / Clean away residues thoroughly before the grout sets using water and a non-abrasive sponge, taking care not to damage the surface of the slab. / Avant le durcissement du mortier, prendre soin d'éliminer les résidus avec de l'eau et une éponge non abrasive, en évitant d'endommager la surface de la dalle. / Rückstände sind vor der Aushärtung mit Wasser und einem weichen Schwamm abzuwaschen, wobei darauf zu achten ist, dass die Oberfläche nicht beschädigt wird. / Antes de que se endurezcan, límpiense los restos de rejunte con agua y una esponja no abrasiva procurando no estropear la superficie de la placa.</p>
<p>PULIZIA QUOTIDIANA DAILY MAINTENANCE ENTRETIEN QUOTIDIEN UNTERHALTSREINIGUNG LIMPIEZA COTIDIANA</p>	<p>Utilizzare detergenti neutri e/o acqua, pulendo con straccio in microfibra o spugna morbida. Prodotti acidi anticalcare possono essere utilizzati avendo cura di risciacquare rapidamente la superficie con acqua dopo l'applicazione. Non utilizzare solventi (alcol e simili) né spugne abrasive. / Use neutral detergents and/or water, cleaning with a micro-fibre cloth or soft sponge. Acid limescale remover products may be used, but take care to rinse the surface with water quickly after application. Do not use solvents (alcohols and similar substances) or abrasive sponges. / Laver avec des détergents neutres et/ou de l'eau, avec un chiffon microfibre ou une éponge douce. Les produits acides anticalcaires peuvent être utilisés à condition de rincer rapidement la surface à l'eau après application. Ne pas utiliser de solvants (alcools et similaires) ni d'éponges abrasives. / Neutrale Reinigungsmittel und/oder Wasser sowie ein abfaserndes oder nicht abrasives Reinigungsmittel verwenden. / Utilizar detergentes neutros y/o agua y limpiar con trapos de microfibra o esponjas suaves. Se pueden utilizar productos ácidos anticálcal y cuando, tras su aplicación, se aclare de inmediato la superficie con agua. Evite el uso de esponjas abrasivas y de disolventes (como alcohol o similares).</p>

Lastre decorate destinate esclusivamente al rivestimento di pareti interne. / Decorated panels designed exclusively for tiling interior walls. / Dalles décorées, exclusivement destinées au revêtement de parois intérieures. Verzierte Platten, ausschließlich zur Verkleidung von Innenwänden bestimmt. / Losas decoradas destinadas exclusivamente al revestimiento de paredes interiores.

Gres porcellanato decorato: florim indica di stoccare il materiale in magazzini coperti o al riparo da agenti atmosferici / Florim recommends to stock the goods in covered warehouses, do not expose to the elements Florim conseille de stocker le matériel dans des entrepôts couverts ou à l'abri des agents atmosphériques / Florim empfiehlt, das Material in geschlossenen Lagern oder in vor Witterungseinfüssen geschützten Bereichen zu lagern. / Florim indica almacenar el material en locales cubiertos o protegido de los agentes atmosféricos.

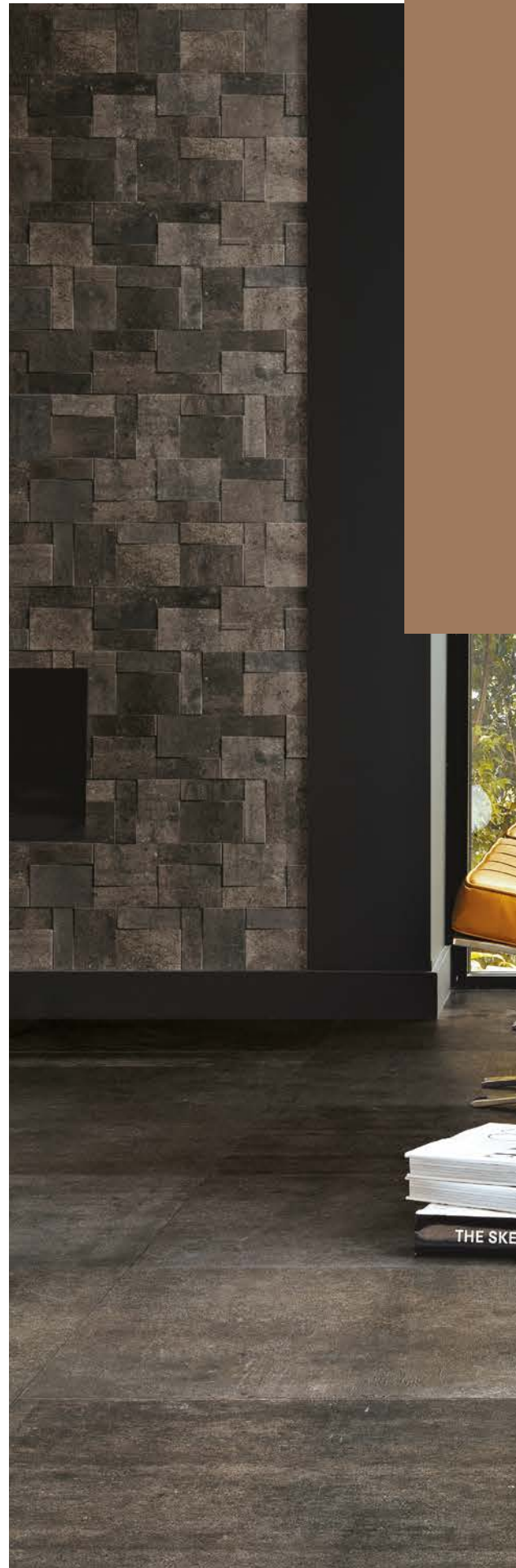

LA ROCHE

gres fine porcellanato
fine porcelain stoneware
grès cérame fin
feinsteinzeug-kollektionen
gres porcelánico fino





LA ROCHE

Dall'intesa fra natura e uomo prende forma **La roche**, pietra densa di stratificazioni dal sapore francese. Luxury design esplora eleganti contrasti in cui il fascino romantico della pietra prorompe grazie ad accostamenti dal sapore contemporaneo.

The relationship between man and nature shapes **La roche**: a french-style sedimentary stone. Luxury design explores elegant contrasts where the romantic charm of the stone bursts through combinations rich in contemporary flavour.

La Roche voit le jour de l'entente entre la nature et l'homme, pierre dense en stratifications de style français. Luxury design explore d'élégants contrastes dont la fascination romantique de la pierre éclate grâce à des approches au style contemporain.

Aus dem Einklang zwischen Natur und Mensch entspringt **La Roche**: ein schichtenreicher Stein mit französischem Flair. Luxury design erkundet elegante Kontraste, in denen der romantische Zauber des Steins dank moderner Kombinationen voll zur Geltung kommt.

Del acuerdo entre el hombre y la naturaleza nace **La Roche**, piedra densa de estratificaciones con gusto francés. Luxury design explora contrastes elegantes con la fascinación romántica de la piedra que prorrumpe gracias a combinaciones de gusto contemporáneo.

LA ROCHE

LA ROCHE BLANC



LA ROCHE ECRU



V3

R9
(smooth)

R10
CLASSE A
(anticato naturale)

R11
CLASSE B
(strutturato)

DCOF>
0,42 Wet

9 mm 3/8" ↑↓



V3





DCOF>
0,42 Wet

6 mm 1/4" ↑↓

FLORIM OVERSIZE
magnum

GRES FINE PORCELLANATO

FINE PORCELAIN STONEWARE/GRES CERAME FIN/FEINSTEINZEUG-KOLLEKTIONEN/GRES PORCELANICO FINO
SQUADRATO - SQUARED - EQUARRI - REKTIFIZIERT - ESCUADRADO

9 mm 3/8" ↑↓		COLOR	SURFACE	80x80 31 1/2" x 31 1/2"	40x80 15 3/4" x 31 1/2"	60x120 23 5/8" x 47 1/4"	60x60 23 5/8" x 23 5/8"
LA ROCHE		LA ROCHE BLANC	ANTICATO NATURALE	742034 ■ FL-09300	742038 ■ FL-07000	741767 ■ FL-10300	742211 ■ FL-07000
			STRUTTURATO BORDO DRITTO	-	742714 ■ FL-07000	-	-
			SMOOTH BORDO DRITTO	742710 ■ FL-09300	-	-	-
		LA ROCHE ECRU	ANTICATO NATURALE	742035 ■ FL-09300	742039 ■ FL-07000	741784 ■ FL-10300	742212 ■ FL-07000
			STRUTTURATO BORDO DRITTO	-	742716 ■ FL-07000	-	-
			SMOOTH BORDO DRITTO	742712 ■ FL-09300	-	-	-
6 mm 1/4" ↑↓		COLOR	SURFACE	120x280 47 1/4" x 110"	120x240 47 1/4" x 94 1/2"	120x120 47 1/4" x 47 1/4"	60x120 23 5/8" x 47 1/4"
LA ROCHE		LA ROCHE BLANC	SMOOTH	758829 ■ FL-12400	744488 ■ FL-11300	744493 ■ FL-09700	744498 ■ FL-09100
				LA ROCHE ECRU	SMOOTH	758831 ■ FL-12400	744490 ■ FL-11300

LA ROCHE GREY



LA ROCHE MUD



V3

R9
(smooth)

R10
CLASSE A
(anticato naturale)

R11
CLASSE B
(strutturato)

DCOF>
0,42 Wet

9 mm 3/8" ↑↓



V3



DCOF>
0,42 Wet

6 mm 1/4" ↑↓







FLORIM OVERSIZE
magnum

GRES FINE PORCELLANATO

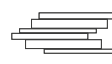





FINE PORCELAIN STONEWARE/GRES CERAME FIN/FEINSTEINZEUG-KOLLEKTIONEN/GRES PORCELANICO FINO
SQUADRATO - SQUARED - EQUARRI - REKTIFIZIERT - ESCUADRADO

9 mm 3/8" ↑↓		COLOR	SURFACE	80x80 31 1/2" x 31 1/2"	40x80 15 3/4" x 31 1/2"	60x120 23 5/8" x 47 1/4"	60x60 23 5/8" x 23 5/8"
LA ROCHE		LA ROCHE GREY	ANTICATO NATURALE	742036 ■ FL-09300	742040 ■ FL-07000	741785 ■ FL-10300	742213 ■ FL-07000
			STRUTTURATO BORDO DRITTO	-	742715 ■ FL-07000	-	-
			SMOOTH BORDO DRITTO	742711 ■ FL-09300	-	-	-
		LA ROCHE MUD	ANTICATO NATURALE	742037 ■ FL-09300	742041 ■ FL-07000	741786 ■ FL-10300	742214 ■ FL-07000
			STRUTTURATO BORDO DRITTO	-	742717 ■ FL-07000	-	-
			SMOOTH BORDO DRITTO	742713 ■ FL-09300	-	-	-
6 mm 1/4" ↑↓		COLOR	SURFACE	120x280 47 1/4" x 110 1/4"	120x240 47 1/4" x 94 1/2"	120x120 47 1/4" x 47 1/4"	60x120 23 5/8" x 47 1/4"
LA ROCHE		LA ROCHE GREY	SMOOTH	758830 ■ FL-12400	744489 ■ FL-11300	744494 ■ FL-09700	744499 ■ FL-09100

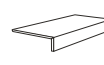
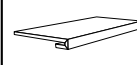
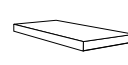
LA ROCHE

9 mm 3/8" ↑↓		COLOR	SURFACE	30x30 11 ^{4/5"} x11 ^{4/5"}  mosaico tessere 5x5	21x40 8 ^{1/4"} x15 ^{3/4"}  modulo listello sfalsato mix anticato naturale/strutturato	30x30 11 ^{4/5"} x11 ^{4/5"}  modulo muretto 3D pz/box 6
	LA ROCHE BLANC	ANTICATO NATURALE	742228 ■ FL-15600	742236 ■ FL-21500	742240 ▲ FL-03600	
	LA ROCHE ECRU	ANTICATO NATURALE	742229 ■ FL-15600	742237 ■ FL-21500	742241 ▲ FL-03600	
	LA ROCHE GREY	ANTICATO NATURALE	742230 ■ FL-15600	742238 ■ FL-21500	742242 ▲ FL-03600	
	LA ROCHE MUD	ANTICATO NATURALE	742231 ■ FL-15600	742239 ■ FL-21500	742243 ▲ FL-03600	

PEZZI SPECIALI/SPECIAL TRIMS/PIÈCES SPÉCIALES/FORMSTÜCKE/PIEZAS ESPECIALES

9 mm 3/8" ↑↓		COLOR	SURFACE	4,6x60 1 ^{4/5"} x23 ^{5/8"}  battiscopa	15,2x30,4x4 6"x12" x1 ^{4/7"}  elemento Elle strutturato pz/box 6	33x120x3 13"x47 ^{1/4"} x1 ^{1/8"}  gradino pz/box 2	33x120x3 13"x47 ^{1/4"} x1 ^{1/8"}  angolo gradino DX pz/box 2	33x120x3 13"x47 ^{1/4"} x1 ^{1/8"}  angolo gradino SX pz/box 2
	LA ROCHE BLANC	ANTICATO NATURALE	745449 ◆ FL-01600	742248 ▲ FL-02400	742252 ▲ FL-20400	742256 ▲ FL-31100	742260 ▲ FL-31100	
	LA ROCHE ECRU	ANTICATO NATURALE	745450 ◆ FL-01600	742249 ▲ FL-02400	742253 ▲ FL-20400	742257 ▲ FL-31100	742261 ▲ FL-31100	
	LA ROCHE GREY	ANTICATO NATURALE	745451 ◆ FL-01600	742250 ▲ FL-02400	742254 ▲ FL-20400	742258 ▲ FL-31100	742262 ▲ FL-31100	
	LA ROCHE MUD	ANTICATO NATURALE	745452 ◆ FL-01600	742251 ▲ FL-02400	742255 ▲ FL-20400	742259 ▲ FL-31100	742263 ▲ FL-31100	









Per anticato si intende materiale con bordo irregolare. / "Antique finish" means tiles with an uneven edge. / Le terme « vieilli » désigne un matériau au bord irrégulier. / Unter Antik versteht man ein Material mit unregelmäßigem Rand. / Por "envejecido" se entiende el material con borde irregular.

In relazione alle differenti tecnologie produttive l'accostamento di prodotti con spessori diversi potrebbe presentare delle disomogeneità, se ne sconsiglia pertanto l'abbinamento. / Due to the different production technologies, contiguous installation of products with different thickness may give a non-homogeneous result. For this reason we do not recommend this option. / Vu que différentes technologies de production sont utilisées avec des épaisseurs différentes, des problèmes d'homogénéité pourraient se présenter, il est donc déconseillé de les poser ensemble. / Wegen unterschiedlicher Produktionstechnologien können die Fliesen mit verschiedenen Materialstärken optische Differenzen aufweisen. Von einem direkten Aneinanderlegen wird deshalb abgeraten. / Dadas las diferentes tecnologías productivas, la combinación de productos de diferentes espesores podría dar lugar a heterogeneidad, por lo que se desaconseja mezclarlas.

Per un effetto ottimale della posa, florim suggerisce di mantenere 2 mm di fuga per pose monoformato e 3 mm per combinare formati misti. - For optimal installation results, florim recommends maintaining a joint of 2 mm 1/12" for single format installations and 3 mm 1/8" to combine mixed formats. - Pour réaliser une pose parfaite, florim suggère de maintenir 2 mm de joint pour la pose des monoformats, et 3 mm pour les combinaisons de formats mixtes. - Um einen optimalen Effekt beim Verlegen zu erzielen empfiehlt florim eine 2 mm fugе bei einformatigen Verlegungen und 3 mm fugе bei formatkombinationen. Para lograr los máximos resultados en la posa del producto, florim aconseja 2 mm de junta en aplicaciones monoformato y 3 mm en combinaciones de formatos mixtos.

LA ROCHE	scatola - box			pallet		
	pz	mq	kg	box	mq	kg
80x80	2	1,28	24,96	40	51,20	1030
40x80	3	0,96	18,53	56	53,76	1070
60x120	2	1,44	28,08	30	43,20	870
60x60	3	1,08	21,06	40	43,20	870
30x30 mosaico	11	1,00	23,00	30	30,00	720
21x40 modulo list.sfals.	5	0,42	9,66	40	16,80	420

LA ROCHE	scatola - box			pallet		
	pz	ml	kg	box	mq	kg
4,6x60 battiscopa	14	8,40	8,40	-	-	-

6 mm 1/4" ↑↓				30x30 $11\frac{4}{5}'' \times 11\frac{4}{5}''$  mosaico tessere 7,5x7,5 pz/box 11	30x30 $11\frac{4}{5}'' \times 11\frac{4}{5}''$  muretto tessere 7,5x15 pz/box 11	30x30 $11\frac{4}{5}'' \times 11\frac{4}{5}''$  mosaico tessere 1,5x3 pz/box 11
		COLOR	SURFACE			
LA ROCHE		LA ROCHE BLANC	SMOOTH	747765 ▲ FL-01800	747795 ▲ FL-01800	747818 ▲ FL-02700
		LA ROCHE ECRU	SMOOTH	747766 ▲ FL-01800	747796 ▲ FL-01800	747819 ▲ FL-02700
		LA ROCHE GREY	SMOOTH	747767 ▲ FL-01800	747797 ▲ FL-01800	747820 ▲ FL-02700

PEZZI SPECIALI/SPECIAL TRIMS/PIÈCES SPÉCIALES/FORMSTÜCKE/PIEZAS ESPECIALES

6 mm 1/4" ↑↓				4,6x80 $1\frac{4}{5}'' \times 3\frac{1}{2}''$  battiscopa
		COLOR	SURFACE	
LA ROCHE		LA ROCHE BLANC	SMOOTH	747880 ◆ FL-01800
		LA ROCHE ECRU	SMOOTH	747881 ◆ FL-01800
		LA ROCHE GREY	SMOOTH	747882 ◆ FL-01800

LA ROCHE OUTDOOR

Vantaggi tecnici - Technical advantages - Avantages techniques Technische Vorteile - Ventajas técnicas

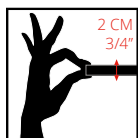

- Lastra monolitica compatta di spessore 2 cm squadrata e rettificata
- Compact monolithic slab 2 cm thick squared and rectified
- Dalle monolithique compacte de 2 cm d'épaisseur, équaree et rectifiée
- Kompakte monolithische Platte, 2 cm dick, rechteckig und scharfkantig geschliffen
- Losa monolítica compacta de 2 cm de espesor, es cuadrada y rectificada.

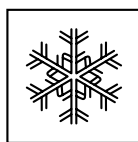

- INGELIVO
- FROST RESISTANT
- INGÉLIF
- FROSTBESTÄNDIG
- RESISTENTE A LA HELADA



- ELEVATA RESISTENZA AI CARICHI STATICI
- HIGH STATIC LOAD RESISTANCE
- RÉSISTANCE ÉLEVÉE AUX CHARGES STATIQUES
- HOHE STATISCHE BELASTBARKEIT
- ELEVADA RESISTENCIA A LAS CARGAS ESTÁTICAS

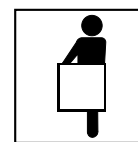

- FACILE DA POSARE
- EASY TO INSTALL
- FACILE À POSER
- VERLEGELEICHT
- FÁCIL DE COLOCAR



- ANTISCIVOLO R11
- ANTI SLIP R11
- ANTIDÉRAPANT R11
- RUTSCHFEST R11
- ANTIDESLIZANTE R11

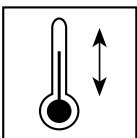

- RESISTENTE AGLI SBALZI TERMICI
- THERMAL SHOCK RESISTANT
- RÉSISTANT AUX ÉCARTS THERMIQUES
- TEMPERATURWECHSELBESTÄNDIG
- RESISTENTE A LAS OSCILACIONES TÉRMICAS



- FACILE DA PULIRE
- EASY TO CLEAN
- FACILE À NETTOYER
- REINIGUNGSLEICHT
- FÁCIL DE LIMPIAR

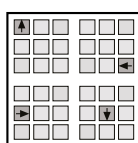

- RIMOVIBILE E RIUTILIZZABILE
- REMOVABLE AND REUSABLE
- DÉMONTABLE ET RÉUTILISABLE
- ENTFERNBAR UND WIEDERVERWENDBAR
- DESMONTABLE Y REUTILIZABLE



- INATTACCABILE DA AGENTI CHIMICI E MUFFE
- IMPERVIUS TO ATTACK BY CHEMICALS OR MOULD
- RÉSISTANT AUX AGENTS CHIMIQUES ET AUX MOISSISSURES
- UNANGREIFBAR DURCH CHEMISCHE STOFFE UND SCHIMMEL
- RESISTENTE A LOS AGENTES QUÍMICOS Y A LOS MOHOS

Applicazioni - Applications - Applications - Verlegung - Aplicaciones

- Posa diretta su erba
- Direct installation on grass
- Pose direct sur de l'herbe
- Verlegung direkt auf Rasen
- Colocación directa sobre hierba



- Posa diretta su ghiaia
- Direct installation over gravel
- Pose direct sur du gravier
- Verlegung direkt auf Kies
- Colocación directa sobre grava



- Posa su massetto cementizio
- Installation on sand-cement screed
- Pose sur chape ciment
- Verlegung auf Zement-Unterbetonblock
- Colocación sobre contrapiso de hormigón

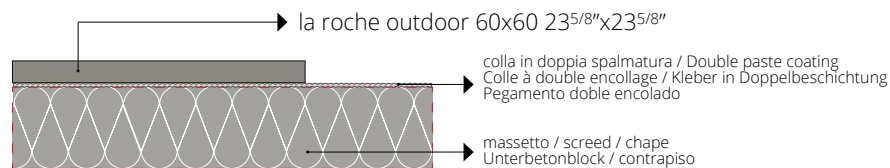

- Posa su piedini fissi o regolabili
- Installation on fixed or adjustable feet
- Pose sur pieds fixes ou réglables
- Verlegung auf feststehende oder regulierbare Füße
- Colocación sobre pies fijos o regulables

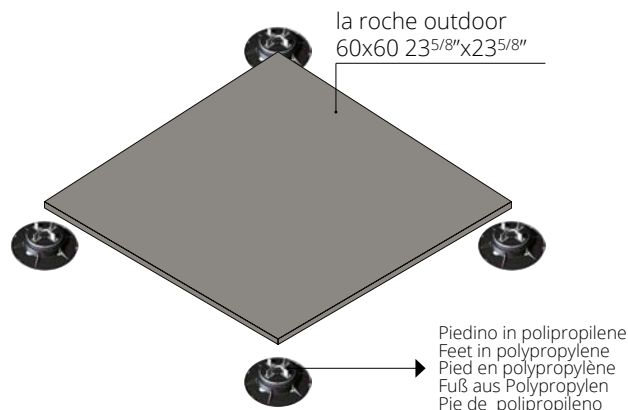

Per le specifiche di utilizzo dei sistemi sopraelevati vedi il sito florim.com
For the specifics on use of raised systems visit the site florim.com
Pour les caractéristiques d'utilisation des systèmes surélevés, voir le site florim.com
Für die Nutzungsbedingungen der Doppelbodensysteme siehe Webseite florim.com
Para las especificaciones de empleo de los sistemas sobreelevados consulte el sitio web florim.com

Le lastre ceramiche sono sottoposte a un trattamento di compattazione termica che assicura resistenza e durata nel tempo. Il bassissimo assorbimento d'acqua rende perciò il materiale ingelivo. Ciò può comportare ristagni d'acqua superficiali anche per materiale installato a regola d'arte. / Ceramic tiles undergo a compacting thermal treatment that ensures resistance and durability. The low level of water absorption makes the slabs frost resistant. This could result in superficial water stagnations even if materials are installed in a workmanlike manner. / Les carreaux de céramique subissent un traitement thermique de compactage qui assure résistance et durabilité. Le bas niveau d'absorption d'eau rend les dalles résistant au gel. Il pourrait en résulter des stagnations d'eau superficielles, même si les dalles ont été installées dans les règles de l'art. / Die Keramikplatten werden einer thermischen Verdichtung unterzogen, welche die Widerstandsfähigkeit und Langlebigkeit sichert. Die extrem niedrige Wasseraufnahme macht das Material frostsicher. Die hohe Materialdichte kann, auch bei einer perfekten Verlegung, eine längere Abtrocknungszeit von angestaumtem Wasser zur Folge haben. / Las baldosas cerámicas se someten a un tratamiento de compactación térmica que asegura resistencia y durabilidad. La baja absorción de agua hace que las baldosas resistan al hielo. Esto podría resultar en estancamientos superficiales de agua, incluso si los materiales están instalados según las reglas del arte.

LA ROCHE ECRU



LA ROCHE GREY



V3

R11
(strutturato)

CLASSE
A+B

20 mm 3/4" ↑↓

GRES FINE PORCELLANATO

FINE PORCELAIN STONEWARE/GRES CERAME FIN/FEINSTEINZEUG-KOLLEKTIONEN/GRES PORCELANICO FINO

SQUADRATO - SQUARED - EQUARRI - REKTIFIZIERT - ESCUADRADO

20 mm 3/4" ↑↓

	COLOR	SURFACE	40x120 15 ^{3/4"} x47 ^{1/4"}	60x60 23 ^{5/8"} x23 ^{5/8"}
LA ROCHE	LA ROCHE ECRU	STRUTTURATO	744631 ■ FL-10800	744629 ■ FL-07700
	LA ROCHE GREY	STRUTTURATO	744632 ■ FL-10800	744630 ■ FL-07700

	RESISTENZA ALLA FLESSIONE IN N/mm² N/mm ² FLEXURAL STRENGTH TEST / RESISTANCE A LA FLEXION EN N/mm ² / BIEGESTIGKEIT IN N/mm ² / RESISTENCIA A LA FLEXION EN N/mm ²	valore medio 52 N/mm²
	Forza di rottura in N (sp. > 7,5 mm) Breaking strength in N (thickness > 7,5 mm) / Force de rupture en N (ép. > 7,5 mm) / Bruchlast in N (Dicke > 7,5 mm) / Fuerza de rotura en N (gr. > 7,5 mm)	valore medio 14000 N

Product Certification
BUREAU VERITAS
Certification

Recycled material content certification



LA ROCHE	scatola - box			pallet		
	pz	mq	kg	box	mq	kg
40x120 20mm	2	0,96	43,10	24	23,04	1060
60x60 20mm	2	0,72	32,15	30	21,60	990

PEZZI SPECIALI

Special trims/Pièces spéciales/Formstücke
Piezas especiales/СПЕЦИАЛЬНЫЕ ИЗДЕЛИЯ
pag 194/197



LES BIJOUX

gres porcellanato colorato in massa
coloured body porcelain stoneware
grès cérame colore dans la masse
durchgefärbte feinsteinzeug
gres porcelánico coloreado en masa





LES BIJOUX

Proseguendo la singolare e seducente proposta di Étoile, la collezione **Les Bijoux** trova la propria ispirazione in fonti diverse ma tutte di respiro artistico, inteso in un ampio significato: nobili minerali abilmente lavorati per la creazione di ricercati gioielli artigianali, meravigliosi marmi utilizzati nella realizzazione di importanti architetture e sculture, persino dipinti di celebri artisti. Se l'arte stessa attribuisce valore all'espressione estetica e a qualsiasi forma di creatività in grado di trasmettere emozioni e messaggi "soggettivi", che possano essere interiorizzati e interpretati dall'individuo, l'essenza di questa collezione risiede proprio nella possibilità di comunicare un fascino artistico attraverso lo stile e la grande forza espressiva tipica di Luxury design. Da questo interessante binomio nascono prodotti avvolgenti e dalle cromie molto originali.

In the same vein as the unique and alluring proposal of Étoile, the inspiration behind the collection **Les Bijoux** comes from sources that are different yet all with an artistic reach, in its widest sense: prized minerals skilfully crafted to make refined handmade jewels, magnificent marbles used in the creation of important architecture and sculptures, even paintings by famous artists. If art itself places value on aesthetic expression and any form of creativity able to convey emotions and "subjective" messages, which can be internalized and interpreted by the individual, the essence of this collection lies in its ability to convey an artistic allure through the style and the great eloquence typical of the Luxury design. This interesting pairing gives life to enveloping products with truly original colours.

C'est en poursuivant la proposition singulière et séduisante d'Étoile que la collection **Les Bijoux** trouve son inspiration dans des sources différentes mais toutes artistiques, au sens large du terme: des minéraux nobles travaillés pour la création de bijoux artisanaux raffinés, des marbres merveilleux utilisés dans la réalisation d'architectures et de sculptures importantes, voire même des tableaux d'artistes célèbres. Si l'art lui-même valorise l'expression esthétique et toute forme de créativité en mesure de transmettre des émotions et des messages « subjectifs », que l'individu peut intérioriser et interpréter, l'essence de cette collection réside précisément dans la possibilité de communiquer un charme artistique à travers le style et la grande force d'expression typique de Luxury design. C'est de ce binôme intéressant que naissent des produits enveloppants aux couleurs très originales.

Die Kollektion **Les Bijoux** setzt das einzigartige, verführerische Angebot von Étoile fort und findet ihre Inspiration in verschiedenen Quellen, die aber alle künstlerisch angehaucht sind und in einer breit angelegten Bedeutung zu verstehen sind: edle Mineralien, die für auserlesene handgefertigte Schmuckobjekte verarbeitet werden, wunderbare Marmore, die zur Schaffung wichtiger architektonischer Baulösungen und Skulpturen eingesetzt werden, und sogar Gemälde berühmter Künstler. Wenn gar die Kunst dem ästhetischen Ausdruck und jeder Form von Kreativität den Wert beimisst, „subjektive“ Erlebnisse und Botschaften herbeizuführen, die vom Menschen verinnerlicht und gedeutet werden können, so liegt das Wesen dieser Kollektion genau darin, durch den Stil und die große Ausdruckskraft - die für die Luxury design ein typisches Merkmal ist - einen künstlerischen Charme zu vermitteln. Aus dieser interessanten Kombination entstehen umhüllende Produkte, deren Farbtöne von großer Originalität zeugen.

Continuando con la singular y seductora propuesta de Étoile, la colección **Les Bijoux** encuentra su propia inspiración en fuentes distintas, aunque todas con un toque artístico entendido en un amplio significado: minerales nobles elaborados con maestría para la creación de joyas artesanales sofisticadas, mármoles maravillosos utilizados en la realización de importantes arquitecturas, esculturas e incluso cuadros de artistas célebres. Si el arte en sí atribuye valor a la expresión estética y a cualquier forma de creatividad capaz de transmitir emociones y mensajes "subjektivos" que puedan ser interiorizados e interpretados por las personas, la esencia de esta colección reside precisamente en la posibilidad de comunicar un encanto artístico a través del estilo y la gran fuerza expresiva típica de Luxury design. De esta interesante combinación nacen productos cautivadores y con tonos muy originales.

LES BIJOUX

CALACATTA ALTISSIMO BLANC ONYX BLANCHE



9 mm 3/8" ↑↓

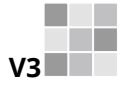

6 mm 1/4" ↑↓

FLORIM OVERSIZE
magnU™

GRES PORCELLANATO COLORATO IN MASSA/COLOURED BODY PORCELAIN STONEWARE
GRÈS CÉRAME COLORE DANS LA MASSE/DURCHGEFÄRBTE FEINSTEINZEUG/GRES PORCELÁNICO COLOREADO EN MASA
SQUADRATO - SQUARED - EQUARRI - REKTIFIZIERT - ESCUADRADO

9 mm 3/8" ↑↓		COLOR	SURFACE	80x180 31 1/2" x 70 5/7"	80x80 31 1/2" x 31 1/2"	60x120 23 5/8" x 47 1/4"	60x60 23 5/8" x 23 5/8"
LES BIJOUX		CALACATTA ALTISSIMO BLANC	GLOSSY	766091 ■ FL-11900	766365 ■ FL-10800	766330 ■ FL-11300	766342 ■ FL-09100
			MATTE	766086 ■ FL-10500	766364 ■ FL-09300	766329 ■ FL-09900	766339 ■ FL-07300
		ONYX BLANCHE	GLOSSY	766090 ■ FL-11900	766363 ■ FL-10800	766328 ■ FL-11300	766338 ■ FL-09100
			MATTE	766085 ■ FL-10500	766362 ■ FL-09300	766325 ■ FL-09900	766337 ■ FL-07300

6 mm 1/4" ↑↓		COLOR	SURFACE	120x280 47 1/4" x 110"	120x240 47 1/4" x 94 1/2"	120x120 47 1/4" x 47 1/4"	60x120 23 5/8" x 47 1/4"
LES BIJOUX		CALACATTA ALTISSIMO BLANC	GLOSSY	765697 ■ FL-15100	765721 ■ FL-14000	765759 ■ FL-12400	765781 ■ FL-11300
			MATTE	765682 ■ FL-12400	765713 ■ FL-11300	765751 ■ FL-09700	765773 ■ FL-09100
		ONYX BLANCHE	GLOSSY	765693 ■ FL-15100	765720 ■ FL-14000	765758 ■ FL-12400	765780 ■ FL-11300
			MATTE	765680 ■ FL-12400	765704 ■ FL-11300	765750 ■ FL-09700	765768 ■ FL-09100

OMBRE DE CARAVAGE

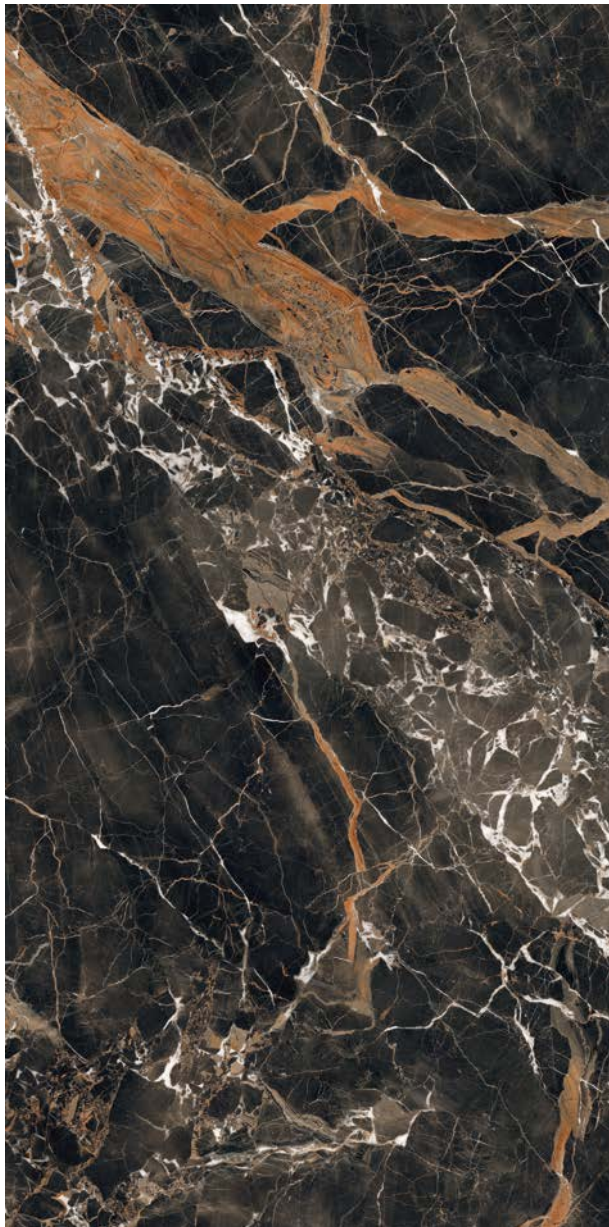

BRÈCHE CAPRAIA



DCOF>
0,42 Wet
(ombre de
caravage
matte)

9 mm 3/8" ↑↓



DCOF>
0,42 Wet
(ombre de
caravage
matte)

6 mm 1/4" ↑↓

FLORM OVERSIZE
magnUm

GRES PORCELLANATO COLORATO IN MASSA/COLOURED BODY PORCELAIN STONEWARE
GRÈS CÉRAME COLORE DANS LA MASSE/DURCHGEFÄRBTE FEINSTEINZEUG/GRES PORCELÁNICO COLOREADO EN MASA
SQUADRATO - SQUARED - EQUARRI - REKTIFIZIERT - ESCUADRADO

9 mm 3/8" ↑↓		COLOR	SURFACE	80x180 31 1/2"x70 5/7"	80x80 31 1/2"x31 1/2"	60x120 23 5/8"x47 1/4"	60x60 23 5/8"x23 5/8"
LES BIJOUX		OMBRE DE CARAVAGE	GLOSSY	766093 ■ FL-11900	766366 ■ FL-10800	766332 ■ FL-11300	766341 ■ FL-09100
			MATTE	766088 ■ FL-10500	766485 ■ FL-09300	766331 ■ FL-09900	766340 ■ FL-07300
		BRÈCHE CAPRAIA	GLOSSY	766092 ■ FL-11900	766375 ■ FL-10800	766333 ■ FL-11300	766344 ■ FL-09100
			MATTE	766087 ■ FL-10500	766486 ■ FL-09300	766334 ■ FL-09900	766343 ■ FL-07300
6 mm 1/4" ↑↓		COLOR	SURFACE	120x280 47 1/4"x110 1/4"	120x240 47 1/4"x94 1/2"	120x120 47 1/4"x47 1/4"	60x120 23 5/8"x47 1/4"
LES BIJOUX		OMBRE DE CARAVAGE	GLOSSY	765698 ■ FL-15100	765723 ■ FL-14000	765761 ■ FL-12400	765782 ■ FL-11300
			MATTE	765683 ■ FL-12400	765714 ■ FL-11300	765752 ■ FL-09700	765774 ■ FL-09100
		BRÈCHE CAPRAIA	GLOSSY	765699 ■ FL-15100	765724 ■ FL-14000	765762 ■ FL-12400	765783 ■ FL-11300
			MATTE	765684 ■ FL-12400	765715 ■ FL-11300	765753 ■ FL-09700	765775 ■ FL-09100

LES BIJOUX

MARRON IMPERIAL



JASPE ROUGE

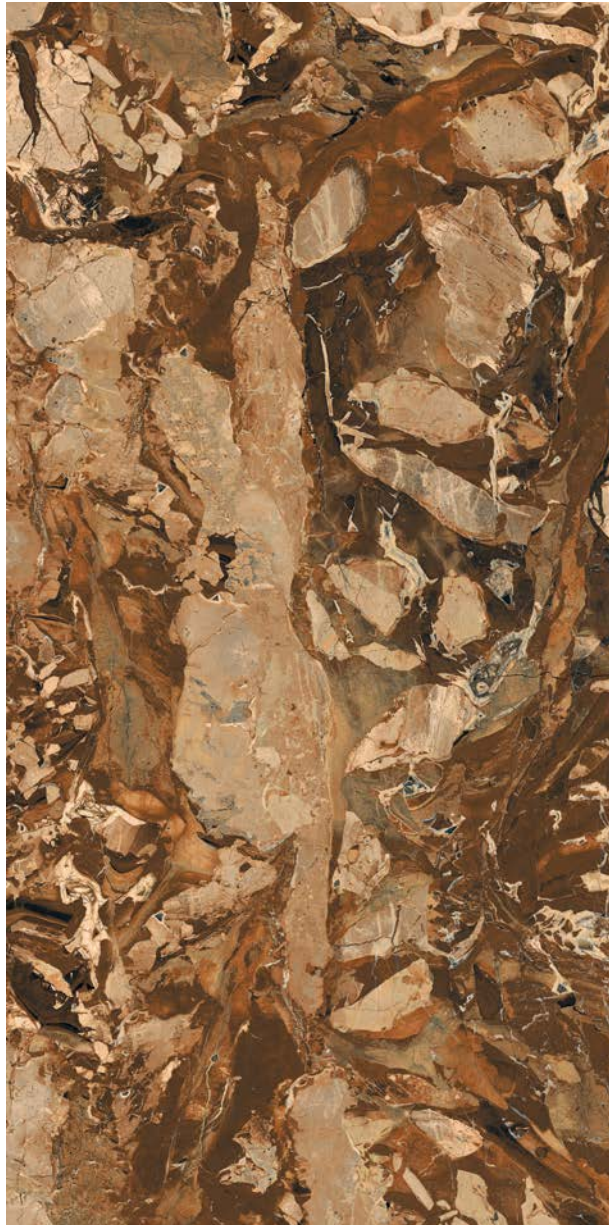

V3
DCOF>
0,42 Wet
(matte)

9 mm 3/8" ↑↓





V3
DCOF>
0,42 Wet
(matte)

6 mm 1/4" ↑↓

FLOHM OVERSIZE
magnUm

GRES PORCELLANATO COLORATO IN MASSA/COLOURED BODY PORCELAIN STONWARE
GRÈS CÉRAMÉ COLORE DANS LA MASSE/DURCHGEFÄRBTE FEINSTEINZEUG/GRES PORCELÁNICO COLOREADO EN MASA
SQUADRATO - SQUARED - EQUARRI - REKTIFIZIERT - ESCUADRADO

			80x180 31 ^{1/2} "x70 ^{5/7} "	80x80 31 ^{1/2} "x31 ^{1/2} "	60x120 23 ^{5/8} "x47 ^{1/4} "	60x60 23 ^{5/8} "x23 ^{5/8} "
LES BIJOUX		MARRON IMPERIAL				
			GLOSSY 766094 ■ FL-11900	766376 ■ FL-10800	766335 ■ FL-11300	766346 ■ FL-09100
		MATTE 766089 ■ FL-10500	766487 ■ FL-09300	766336 ■ FL-09900	766345 ■ FL-07300	

			120x280 47 ^{1/4} "x110 ^{1/4} "	120x240 47 ^{1/4} "x94 ^{1/2} "	120x120 47 ^{1/4} "x47 ^{1/4} "	60x120 23 ^{5/8} "x47 ^{1/4} "
LES BIJOUX		MARRON IMPERIAL				
			GLOSSY 765700 ■ FL-15100	765725 ■ FL-14000	765763 ■ FL-12400	765784 ■ FL-11300
		MATTE 765685 ■ FL-12400	765716 ■ FL-11300	765754 ■ FL-09700	765776 ■ FL-09100	
		JASPE ROUGE				
		GLOSSY 765701 ■ FL-15100	765726 ■ FL-14000	765764 ■ FL-12400	765785 ■ FL-11300	
		MATTE 765686 ■ FL-12400	765717 ■ FL-11300	765755 ■ FL-09700	765777 ■ FL-09100	

SODALITE BLEU

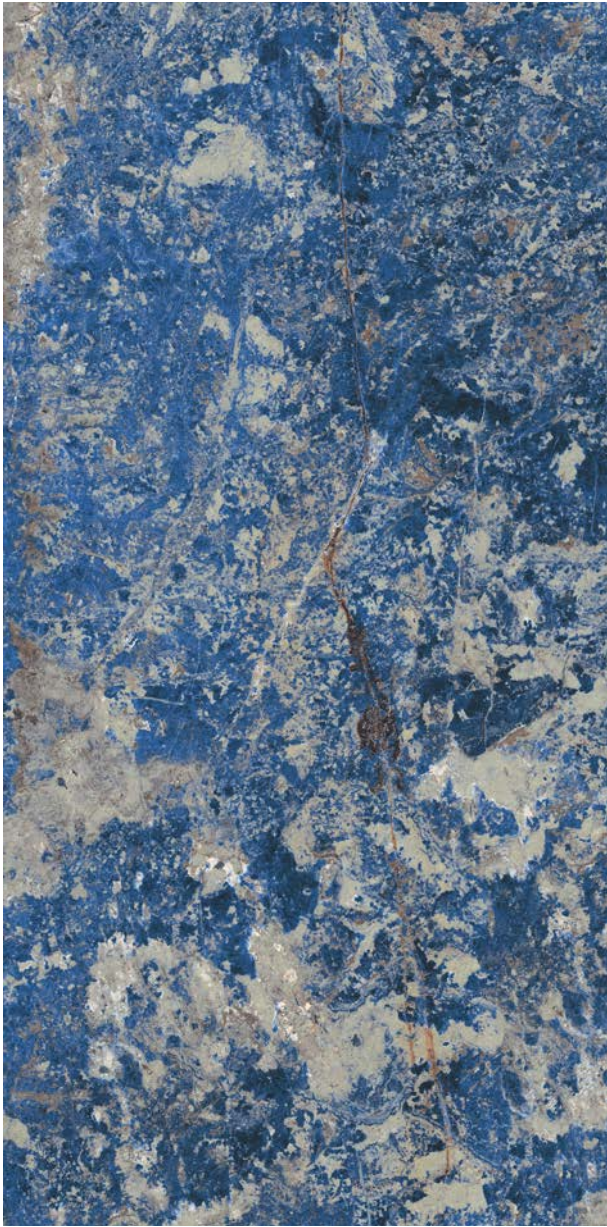



LES QUATRE SAISONS



DCOF>
0,42 Wet
(sodalite bleu matte)









GRES PORCELLANATO COLORATO IN MASSA/COLOURED BODY PORCELAIN STONEWARE
GRÈS CÉRAMÉ COLORE DANS LA MASSE/DURCHGEFÄRBT FEINSTEINZEUG/GRES PORCELÁNICO COLOREADO EN MASA
SQUADRATO - SQUARED - EQUARRI - REKTIFIZIERT - ESCUADRADO



		6 mm 1/4" ↑↓					
		COLOR	SURFACE	120x280 47 ^{11/16"} x110 ^{1/16"}	120x240 47 ^{1/4"} x94 ^{1/2"}	120x120 47 ^{1/16"} x47 ^{1/16"}	60x120 23 ^{5/8"} x47 ^{1/16"}
LES BIJOUX		SODALITE BLEU	GLOSSY	765702 ■ FL-15100	765727 ■ FL-14000	765765 ■ FL-12400	765786 ■ FL-11300
			MATTE	765690 ■ FL-12400	765718 ■ FL-11300	765756 ■ FL-09700	765778 ■ FL-09100
		LES QUATRE SAISONS	GLOSSY	765703 ■ FL-15100	765728 ■ FL-14000	765767 ■ FL-12400	765787 ■ FL-11300
			MATTE	765691 ■ FL-12400	765719 ■ FL-11300	765757 ■ FL-09700	765779 ■ FL-09100

LES BIJOUX

9 mm 3/8" ↑↓

	COLOR	SURFACE	30x30 11 ^{4/5"} x11 ^{4/5"}  mosaico tessere 3x15 pz/box 11	30x30 11 ^{4/5"} x11 ^{4/5"}  mosaico 3D Mix tessere 3x3 pz/box 9
	CALACATTA ALTISSIMO BLANC	GLOSSY	767570 ▲ FL-02200	767565 ▲ FL-04900
		MATTE	767575 ▲ FL-02100	
	ONYX BLANCHE	GLOSSY	767569 ▲ FL-02200	767564 ▲ FL-04900
		MATTE	767574 ▲ FL-02100	
	OMBRE DE CARAVAGE	GLOSSY	767571 ▲ FL-02200	767566 ▲ FL-04900
		MATTE	767576 ▲ FL-02100	
	BRÈCHE CAPRAIA	GLOSSY	767572 ▲ FL-02200	767567 ▲ FL-04900
		MATTE	767577 ▲ FL-02100	
	MARRON IMPERIAL	GLOSSY	767573 ▲ FL-02200	767568 ▲ FL-04900
		MATTE	767578 ▲ FL-02100	

PEZZI SPECIALI/SPECIAL TRIMS/
PIÈCES SPÉCIALES/FORMSTÜCKE
PIEZAS ESPECIALES

4,6x60 1 ^{4/5"} x23 ^{5/8"} 	33x120x3 13 ^{1/4"} x47 ^{1/4"} x1 ^{1/8"} 
battiscopa	gradino pz/box 2
767580 ◆ FL-01600	767590 ▲ FL-22600
767585 ◆ FL-01600	767595 ▲ FL-20400
767579 ◆ FL-01600	767589 ▲ FL-22600
767584 ◆ FL-01600	767594 ▲ FL-20400
767581 ◆ FL-01600	767591 ▲ FL-22600
767586 ◆ FL-01600	767596 ▲ FL-20400
767582 ◆ FL-01600	767592 ▲ FL-22600
767587 ◆ FL-01600	767597 ▲ FL-20400
767583 ◆ FL-01600	767593 ▲ FL-22600
767588 ◆ FL-01600	767598 ▲ FL-20400

LES BIJOUX

In relazione alle differenti tecnologie produttive l'accostamento di prodotti con spessori diversi potrebbe presentare delle disomogeneità, se ne sconsiglia pertanto l'abbinamento. / Due to the different production technologies, contiguous installation of products with different thickness may give a non-homogeneous result. For this reason we do not recommend this option. / Vu que différentes technologies de production sont utilisées avec des épaisseurs différentes, des problèmes d'homogénéité pourraient se présenter, il est donc déconseillé de les poser ensemble. / Wegen unterschiedlicher Produktionstechnologien können die Fliesen mit verschiedenen Materialstärken optische Differenzen aufweisen. Von einem direkten Aneinanderlegen wird deshalb abgeraten. / Dadas las diferentes tecnologías productivas, la combinación de productos de diferentes espesores podría dar lugar a heterogeneidad, por lo que se desaconseja mezclarlas.











Per un effetto ottimale della posa, florim suggerisce di mantenere 2 mm di fuga per pose monofornate e 3 mm per combinare formati misti. - For optimal installation results, florim recommends maintaining a joint of 2 mm - 1/12" for single format installations and 3 mm - 1/8" to combine mixed formats. - Pour réaliser une pose parfaite, florim suggère de maintenir 2 mm de joint pour la pose des monofornats, et 3 mm pour les combinaisons de formats mixtes. - Um einen optimalen effekt beim verlegen zu erzielen empfiehlt florim eine 2 mm fuge bei einformatigen verlegungen und 3 mm fuge bei formatkombinationen Para lograr los máximos resultados en la posa del producto, florim aconseja 2 mm de junta en aplicaciones monofornate y 3 mm en combinaciones de formatos mixtos.

LES BIJOUX	scatola - box			pallet		
	pz	mq	kg	box	mq	kg
80x180	2	2,88	57,60	20	57,60	1210
80x80	2	1,28	24,96	40	51,20	1030
60x120	2	1,44	28,08	30	43,20	870
60x60	3	1,08	21,06	40	43,20	870

LES BIJOUX	scatola - box			pallet		
	pz	ml	kg	box	mq	kg
4,6x60 battiscopa	14	8,40	8,40	-	-	-

PEZZI SPECIALI/SPECIAL TRIMS/
PIÈCES SPÉCIALES/FORMSTÜCKE
PIEZAS ESPECIALES

6 mm 1/4" ↑↓

	COLOR	SURFACE	30x30 11 ^{4/5} "x11 ^{4/5} "  mosaico tessere 7,5x7,5 pz/box 11	30x30 11 ^{4/5} "x11 ^{4/5} "  muretto tessere 7,5x15 pz/box 11	4,6x80 1 ^{4/5} "x31 ^{1/2} "  battiscopa
LES BIJOUX		GLOSSY	767616 ▲ FL-02100	767600 ▲ FL-02100	767632 ◆ FL-01800
		MATTE	767624 ▲ FL-01800	767608 ▲ FL-01800	767637 ◆ FL-01800
		GLOSSY	767615 ▲ FL-02100	767599 ▲ FL-02100	767631 ◆ FL-01800
		MATTE	767623 ▲ FL-01800	767607 ▲ FL-01800	767636 ◆ FL-01800
		GLOSSY	767617 ▲ FL-02100	767601 ▲ FL-02100	767633 ◆ FL-01800
		MATTE	767625 ▲ FL-01800	767609 ▲ FL-01800	767638 ◆ FL-01800
		GLOSSY	767618 ▲ FL-02100	767602 ▲ FL-02100	767634 ◆ FL-01800
		MATTE	767626 ▲ FL-01800	767610 ▲ FL-01800	767639 ◆ FL-01800
		GLOSSY	767619 ▲ FL-02100	767603 ▲ FL-02100	767635 ◆ FL-01800
		MATTE	767627 ▲ FL-01800	767611 ▲ FL-01800	767640 ◆ FL-01800
		GLOSSY	767620 ▲ FL-02100	767604 ▲ FL-02100	-
		MATTE	767628 ▲ FL-01800	767612 ▲ FL-01800	-
		GLOSSY	767621 ▲ FL-02100	767605 ▲ FL-02100	-
		MATTE	767629 ▲ FL-01800	767613 ▲ FL-01800	-
	GLOSSY	767622 ▲ FL-02100	767606 ▲ FL-02100	-	
	MATTE	767630 ▲ FL-01800	767614 ▲ FL-01800	-	

FLORM OVERSIZE
magnUm

120x280/120x240/120x120/60x120

Specifica Imballo pag.
Packaging specifications on page
Spécifications d'emballage à page
Verpackungsdetail Seite
Especificaciones de embalaje a la página
204/205

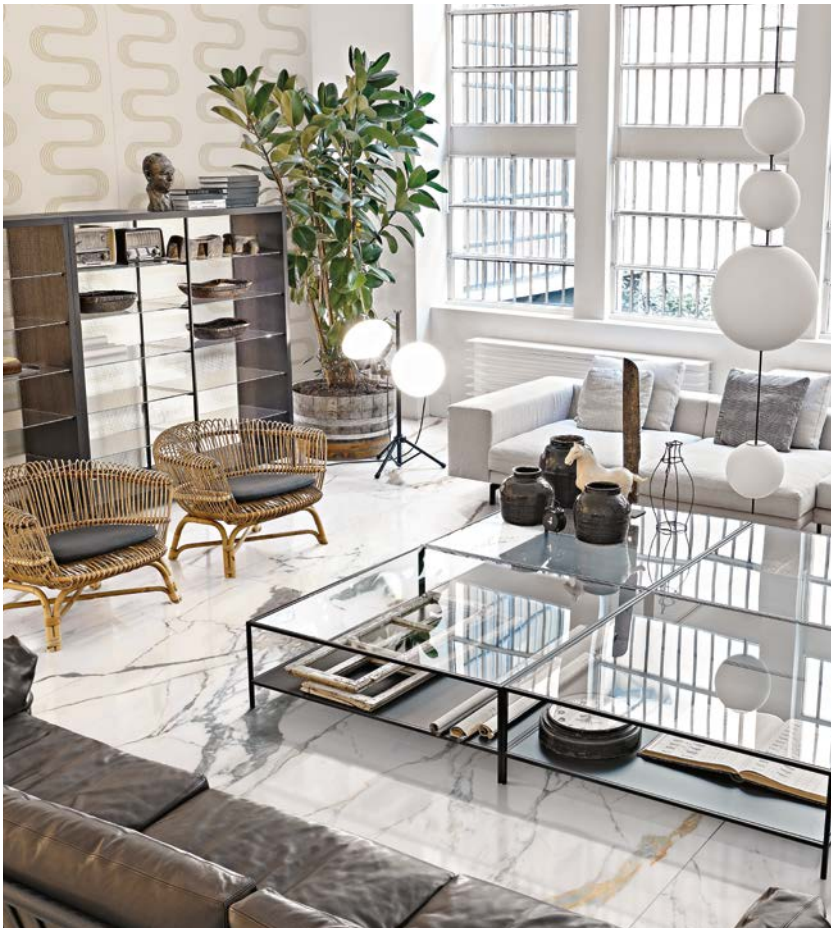

LES ORIGINES

gres porcellanato colorato in massa
coloured body porcelain stoneware
grès cérame colore dans la masse
durchgefärbte feinsteinzeug
gres porcelánico coloreado en masa





LES ORIGINES

Nel lungo e stimolante percorso di ricerca tra le superfici di eterna bellezza, Luxury design ha incontrato le materie più preziose e talvolta inaccessibili che la natura possa offrire. Tra queste il marmo bianco da sempre simbolo di purezza, icona di prestigio ed eleganza. **Les Origines** esplora l'estremo candore di questa limpida materia esaltandolo con nuove declinazioni estetiche che si addicono perfettamente al lifestyle contemporaneo. Quattro raffinate variazioni grafiche impreziosiscono la sua naturale lucentezza con venature armoniche ma decise. Oro antico, avorio, grigio perlato fanno risaltare la sua forte anima cristallina che porta con sé la seducente eredità di una cultura secolare in grado di evocare valori estetici che sfidano il tempo e le mode.

On its long and exhilarating quest amid timeless and beautiful surfaces, Luxury design has discovered the most precious and often inaccessible materials that nature has to offer. Among these, white marble: the quintessential symbol of purity, an icon of prestige and elegance. **Les Origines** explores the extreme whiteness of this limpid material, enhancing it with new aesthetic variations that are perfectly suited to a contemporary lifestyle. Four refined pattern variations embellish its natural shine with harmonious yet bold veins. Antique gold, ivory and pearl grey highlight its vibrant crystalline soul, embodying the seductive heritage of a secular culture whose aesthetic values openly challenge time and fashions.

Dans le long et stimulant voyage de recherche entre les surfaces d'une beauté éternelle, Luxury design a rencontré les matériaux les plus précieux et parfois inaccessibles que la nature peut offrir. Parmi ceux-ci, le marbre blanc a toujours été un symbole de pureté, une icône de prestige et d'élégance. La collection **Les Origines** explore l'extrême blancheur de cette matière limpide, en l'enrichissant de nouvelles déclinaisons esthétiques, parfaitement adaptées au style de vie contemporain. Quatre variations graphiques raffinées agrémentent son éclat naturel de veines à la fois harmonieuses et marquées. L'or ancien, l'ivoire et le gris perle font ressortir sa puissante âme cristalline dont l'héritage séduisant est celui d'une culture séculaire capable d'évoquer des valeurs esthétiques qui défient le temps et la mode.

Auf dem langen und anregenden Forschungsparcours ewig schöner Oberflächen ist Luxury design den kostbarsten und manchmal unzugänglichsten Materialien begegnet, die die Natur bieten kann. Darunter auch dem weißen Marmor, der schon immer das Symbol von Reinheit und eine Ikone des Prestige und der Eleganz ist. **Les Origines** erforscht das extrem reine Weiß dieses klaren Materials und hebt es mit neuen ästhetischen Deklinationen hervor, die perfekt zum zeitgenössischen Lebensstil passen. Vier raffinierte grafische Variationen bereichern seinen natürlichen Glanz mit harmonischen aber entschlossenen Äderungen. Antikgold, Elfenbein, Perlgrau heben sein starkes kristallklares Wesen hervor, das jenes verführerische Erbe einer jahrhundertealten Kultur mit sich bringt, deren ästhetischen Werte das Verstreichen der Zeit und der Moden herausfordert.

En su larga y estimulante trayectoria de búsqueda entre las superficies de belleza eterna, Luxury design ha encontrado las materias más preciosas y a veces inaccesibles que ofrece la naturaleza. Entre ellas se encuentra el mármol blanco, que desde siempre simboliza la pureza y es un icono de prestigio y elegancia. **Les Origines** explora el sumo candor de esta materia límpida y lo realza con nuevas declinaciones estéticas que se adecuan perfectamente al estilo de vida contemporáneo. Cuatro elegantes variaciones gráficas embellecen su brillo natural con vetas armónicas pero audaces. El oro antiguo, el marfil y el gris perla ponen de relieve su fuerte espíritu cristalino, que lleva consigo el seductor legado de una cultura secolar, capaz de evocar valores estéticos que trascienden el tiempo y las modas.

LES ORIGINES

ORIGINES OR



ORIGINES ARGENT

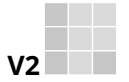

V2
DCOF >
0,42 Wet
(matte)

9 mm 3/8" ↑↓

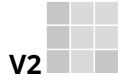

V2
DCOF >
0,42 Wet
(matte)

6 mm 1/4" ↑↓

FLORM OVERSIZE
magnUm

GRES PORCELLANATO COLORATO IN MASSA/COLOURED BODY PORCELAIN STONEWARE
GRÈS CÉRAME COLORE DANS LA MASSE/DURCHGEFÄRBTE FEINSTEINZEUG/GRES PORCELÁNICO COLOREADO EN MASA
SQUADRATO - SQUARED - EQUARRI - REKTIFIZIERT - ESCUADRADO

				80x180 31 ^{1/2} "x70 ^{6/7} "	60x120 23 ^{5/8} "x47 ^{1/4} "	60x60 23 ^{5/8} "x23 ^{5/8} "	30x60 11 ^{4/5} "x23 ^{5/8} "
9 mm 3/8" ↑↓	ORIGINES OR	GLOSSY	770437 ■ FL-11900	769858 ■ FL-11300	769842 ■ FL-09100	769850 ■ FL-07700	
		MATTE	770433 ■ FL-10500	769854 ■ FL-09900	769838 ■ FL-07300	769846 ■ FL-06200	
	ORIGINES ARGENT	GLOSSY	770438 ■ FL-11900	769859 ■ FL-11300	769843 ■ FL-09100	769851 ■ FL-07700	
		MATTE	770434 ■ FL-10500	769855 ■ FL-09900	769839 ■ FL-07300	769847 ■ FL-06200	
6 mm 1/4" ↑↓	ORIGINES OR	GLOSSY	769953 ■ FL-18800	769978 ■ FL-15100	769970 ■ FL-14000	769962 ■ FL-12400	769986 ■ FL-11300
		MATTE	769949 ■ FL-15600	769974 ■ FL-12400	769966 ■ FL-11300	769958 ■ FL-09700	769982 ■ FL-09100
	ORIGINES ARGENT	GLOSSY	769950 ■ FL-18800	769975 ■ FL-15100	769967 ■ FL-14000	769959 ■ FL-12400	769983 ■ FL-11300
		MATTE	769946 ■ FL-15600	769971 ■ FL-12400	769963 ■ FL-11300	769955 ■ FL-09700	769979 ■ FL-09100

ORIGINES BLANC



ORIGINES OMBRE DORÉE

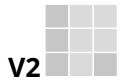

V2
DCOF>
0,42 Wet
(matte)

9 mm 3/8" ↑↓

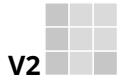

V2
DCOF>
0,42 Wet
(matte)

6 mm 1/4" ↑↓

FLORM OVERSIZE
magnum

GRES PORCELLANATO COLORATO IN MASSA/COLOURED BODY PORCELAIN STONWARE
GRÈS CÉRAMÉ COLORE DANS LA MASSE/DURCHGEFÄRBTE FEINSTEINZEUG/GRES PORCELÁNICO COLOREADO EN MASA
SQUADRATO - SQUARED - EQUARRI - REKTIFIZIERT - ESCUADRADO

9 mm 3/8" ↑↓		COLOR	SURFACE	80x180 31 1/2" x 70 5/7"	60x120 23 5/8" x 47 1/4"	60x60 23 5/8" x 23 5/8"	30x60 11 4/5" x 23 5/8"	
LES ORIGINES		ORIGINES BLANC	GLOSSY	770439 ■ FL-11900	769860 ■ FL-11300	769844 ■ FL-09100	769852 ■ FL-07700	
			MATTE	770435 ■ FL-10500	769856 ■ FL-09900	769840 ■ FL-07300	769848 ■ FL-06200	
		ORIGINES OMBRE DORÉE	GLOSSY	770440 ■ FL-11900	769861 ■ FL-11300	769845 ■ FL-09100	769853 ■ FL-07700	
			MATTE	770436 ■ FL-10500	769857 ■ FL-09900	769841 ■ FL-07300	769849 ■ FL-06200	
6 mm 1/4" ↑↓		COLOR	SURFACE	160x320 63" x 126"	120x280 47 1/4" x 110 1/4"	120x240 47 1/4" x 94 1/2"	120x120 47 1/4" x 47 1/4"	60x120 23 5/8" x 47 1/4"
LES ORIGINES		ORIGINES BLANC	GLOSSY	769952 ■ FL-18800	769977 ■ FL-15100	769969 ■ FL-14000	769961 ■ FL-12400	769985 ■ FL-11300
			MATTE	769948 ■ FL-15600	769973 ■ FL-12400	769965 ■ FL-11300	769957 ■ FL-09700	769981 ■ FL-09100
		ORIGINES OMBRE DORÉE	GLOSSY	769951 ■ FL-18800	769976 ■ FL-15100	769968 ■ FL-14000	769960 ■ FL-12400	769984 ■ FL-11300
			MATTE	769947 ■ FL-15600	769972 ■ FL-12400	769964 ■ FL-11300	769956 ■ FL-09700	769980 ■ FL-09100

LES ORIGINES

9 mm 3/8" ↑↓		COLOR	SURFACE	30x30 11 ^{4/5"} x11 ^{4/5"} mosaico tessere 3x15 pz/box 11	30x30 11 ^{4/5"} x11 ^{4/5"} mosaico 3D Mix tessere 3x3 pz/box 9
LES ORIGINES		ORIGINES OR	GLOSSY	770358 ▲ FL-02200	770350 ▲ FL-04900
			MATTE	770354 ▲ FL-02100	
		ORIGINES ARGENT	GLOSSY	770355 ▲ FL-02200	770347 ▲ FL-04900
			MATTE	770351 ▲ FL-02100	
		ORIGINES BLANC	GLOSSY	770357 ▲ FL-02200	770349 ▲ FL-04900
			MATTE	770353 ▲ FL-02100	
		ORIGINES OMBRE DORÉE	GLOSSY	770356 ▲ FL-02200	770348 ▲ FL-04900
			MATTE	770352 ▲ FL-02100	

PEZZI SPECIALI/SPECIAL TRIMS/PIÈCES SPÉCIALES/FORMSTÜCKE/PIEZAS ESPECIALES/εΏ° Á ÉÁ%äfi

9 mm 3/8" ↑↓		COLOR	SURFACE	4,6x60 1 ^{4/5"} x23 ^{5/8"} battiscopa	33x120x3 13"x47 ^{1/4"} x1 ^{1/8"} gradino pz/box 2
LES ORIGINES		ORIGINES OR	GLOSSY	770366 ◆ FL-01600	770374 ▲ FL-22600
			MATTE	770362 ◆ FL-01600	770370 ▲ FL-20400
		ORIGINES ARGENT	GLOSSY	770363 ◆ FL-01600	770371 ▲ FL-22600
			MATTE	770359 ◆ FL-01600	770367 ▲ FL-20400
		ORIGINES BLANC	GLOSSY	770365 ◆ FL-01600	770373 ▲ FL-22600
			MATTE	770361 ◆ FL-01600	770369 ▲ FL-20400
		ORIGINES OMBRE DORÉE	GLOSSY	770364 ◆ FL-01600	770372 ▲ FL-22600
			MATTE	770360 ◆ FL-01600	770368 ▲ FL-20400



Per un effetto ottimale della posa, florim suggerisce di mantenere 2 mm di fuga per pose monofornate e 3 mm per combinare formati misti - For optimal installation results, florim recommends maintaining a joint of 2 mm 1/12" for single format installations and 3 mm 1/8" to combine mixed formats. - Pour réaliser une pose parfaite, florim suggère de maintenir 2 mm de joint pour la pose des monofornats, et 3 mm pour les combinaisons de formats mixtes. - Um einen optimalen effekt beim verlegen zu erzielen empfiehlt florim eine 2 mm fuge bei einformatigen verlegungen und 3 mm fuge bei formatkombinationen Para lograr los máximos resultados en la posa del producto, florim aconseja 2 mm de junta en aplicaciones monofornate y 3 mm en combinaciones de formatos mixtos.

In relazione alle differenti tecnologie produttive l'accostamento di prodotti con spessori diversi potrebbe presentare delle disomogeneità, se ne sconsiglia pertanto l'abbinamento. / Due to the different production technologies, contiguous installation of products with different thickness may give a non-homogeneous result. For this reason we do not recommend this option. / Vu que différentes technologies de production sont utilisées avec des épaisseurs différentes, des problèmes d'homogénéité pourraient se présenter, il est donc déconseillé de les poser ensemble. / Wegen unterschiedlicher Produktionstechnologien können die Fliesen mit verschiedenen Materialstärken optische Differenzen aufweisen. Von einem direkten Aneinanderlegen wird deshalb abgeraten. / Dadas las diferentes tecnologías productivas, la combinación de productos de diferentes espesores podría dar lugar a heterogeneidad, por lo que se desaconseja mezclarlas.

LES ORIGINES	scatola - box			pallet		
	pz	mq	kg	box	mq	kg
80x180	2	2,88	57,60	20	57,60	1210
60x120	2	1,44	28,08	30	43,20	870
60x60	3	1,08	21,06	40	43,20	870
30x60	6	1,08	20,84	40	43,20	860

LES ORIGINES	scatola - box			pallet		
	pz	ml	kg	box	mq	kg
4,6x60 battiscopa	14	8,40	8,40	-	-	-

6 mm 1/4" ↑↓				30x30 11 ^{4/5"} x11 ^{4/5"} mosaico tessere 7,5x7,5 pz/box 11	30x30 11 ^{4/5"} x11 ^{4/5"} muretto tessere 7,5x15 pz/box 11
		COLOR	SURFACE		
LES ORIGINES		ORIGINES OR	GLOSSY	770390 ▲ FL-02100	770382 ▲ FL-02100
			MATTE	770386 ▲ FL-01800	770378 ▲ FL-01800
		ORIGINES ARGENT	GLOSSY	770387 ▲ FL-02100	770379 ▲ FL-02100
			MATTE	770383 ▲ FL-01800	770375 ▲ FL-01800
		ORIGINES BLANC	GLOSSY	770389 ▲ FL-02100	770381 ▲ FL-02100
			MATTE	770385 ▲ FL-01800	770377 ▲ FL-01800
		ORIGINES OMBRE DORÉE	GLOSSY	770388 ▲ FL-02100	770380 ▲ FL-02100
			MATTE	770384 ▲ FL-01800	770376 ▲ FL-01800

PEZZI SPECIALI/SPECIAL TRIMS/PIÈCES SPÉCIALES/FORMSTÜCKE/PIEZAS ESPECIALES

6 mm 1/4" ↑↓				4,6x60 1 ^{4/5"} x23 ^{5/8"} battiscopa
		COLOR	SURFACE	
LES ORIGINES		ORIGINES OR	GLOSSY	770398 ◆ FL-01800
			MATTE	770394 ◆ FL-01800
		ORIGINES ARGENT	GLOSSY	770395 ◆ FL-01800
			MATTE	770391 ◆ FL-01800
		ORIGINES BLANC	GLOSSY	770397 ◆ FL-01800
			MATTE	770393 ◆ FL-01800
		ORIGINES OMBRE DORÉE	GLOSSY	770396 ◆ FL-01800
			MATTE	770392 ◆ FL-01800



MATIÈRES

gres fine porcellanato
fine porcelain stoneware
grès cérame fin
feinsteinzeug-kollektionen
gres porcelánico fino





MATIÈRES

La sensazione di autenticità e il particolare feeling delle superfici nate dalla lavorazione manuale della materia sono la caratteristica fondamentale di **Matières**. Un attento e appassionato lavoro di perfezionamento ha definito lo sviluppo morbido e differenziato delle sfumature di colore, che nelle ampie superfici mostra una eleganza unica ed un equilibrio estetico che fa la differenza, aumentando la versatilità stilistica della collezione. **Matières** è una superficie perfetta per ambienti contemporanei e di tendenza, ma ha tutta la classe per vestire anche spazi eleganti e sobri. La palette cromatica offre sei toni moderni e originali, che possono creare interessanti combinazioni.

The authentic, special feeling of handworked surfaces is the key feature of **Matières**. A perfectionist attention to detail has resulted in soft, differentiated colour nuances which, on these large surfaces, yields an aesthetic equilibrium which stands out from the crowd and augments the stylistic versatility of the collection. **Matières** is the perfect solution for modern, fashionable settings, with all the class of elegant, sober designs. The colour palette consists of six modern, original tonalities, ideal for combining in unique patterns.

La sensation d'authenticité et l'aspect particulier des surfaces issues du traitement manuel de la matière sont les caractéristiques fondamentales de **Matières**. Un travail de perfectionnement attentif et passionné a permis de développer des nuances de couleur souples et différenciées, d'où transparaît sur les grandes surfaces une élégance unique et un équilibre esthétique qui fait la différence, au bénéfice d'une polyvalence stylistique accrue. **Matières** est parfaitement adaptée aux espaces contemporains et tendance, mais peut également habiller des espaces élégants et sobres. La palette chromatique propose six tons modernes et originaux qui peuvent être utilisés pour créer d'intéressantes combinaisons.

Das Gefühl der Authentizität und die besondere Empfindung der durch die manuelle Bearbeitung der Materie entstandenen Oberflächen sind die wesentliche Charakteristik von **Matières**. Eine sorgfältige und begeisterte Arbeit der Feinabstimmung, die den weichen und differenzierten Verlauf der Farbtöne definierte, der auf den großen Flächen eine einzigartige Eleganz und ästhetische Balance aufweist, die entscheidend sind, und die stilistische Vielseitigkeit der Kollektion erhöhen. **Matières** ist eine perfekte Oberfläche für ein modernes und zeitgemäßes Ambiente, jedoch auch mit dem Stil für elegante und schlichte Räumlichkeiten. Die Farbpalette weist sechs moderne und originelle Farbtöne auf, die spannende Kombinationen schaffen können.

La sensación de autenticidad y el tacto especial de las superficies nacidas de la elaboración manual de la materia son la característica fundamental de **Matières**. Un atento y apasionado trabajo de perfeccionamiento ha definido el desarrollo suave y diferenciado de los matices de color, que en las amplias superficies muestra una elegancia única y un equilibrio estético que marca la diferencia, aumentando la versatilidad estilística de la colección. **Matières** es una superficie perfecta para ambientes contemporáneos y de tendencia, pero tiene toda la clase para vestir también espacios elegantes y sobrios. La paleta cromática ofrece seis tonos modernos y originales que pueden crear combinaciones interesantes.

MATIÈRES

MATIÈRES SABLE



MATIÈRES MOU



R10
(matte)
CLASSE
A+B

R11
(strutturato)
CLASSE
A+B+C

DCOF>
0,42 Wet

9 mm 3/8" ↑↓

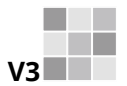

R9
(matte)
CLASSE A

R10
(R+PTV)
CLASSE
A+B

BS EN 16165
ANNEX C
>36 wet
slider 4S





DCOF>
0,42 Wet

6 mm 1/4" ↑↓

FLORM OVERSIZE
magnUm

GRES FINE PORCELLANATO

FINE PORCELAIN STONEWARE/GRES CERAME FIN/FEINSTEINZEUG-KOLLEKTIONEN/GRES PORCELANICO FINO
SQUADRATO - SQUARED - EQUARRI - REKTIFIZIERT - ESCUADRADO

				9 mm 3/8" ↑↓		80x80 31 1/2" x 31 1/2"		40x80 15 3/4" x 31 1/2"		60x120 23 5/8" x 47 1/4"		60x60 23 5/8" x 23 5/8"		30x60 11 4/5" x 23 5/8"		
		COLOR	SURFACE													
MATIÈRES		MATIÈRES SABLE	MATTE	755705 ■ FL-09300	755711 ■ FL-07000	755717 ■ FL-10300	755724 ■ FL-07000	755730 ■ FL-06200								
			STRUTTURATO	-	755736 ■ FL-07000	-	-	-								
		MATIÈRES MOU	MATTE	755706 ■ FL-09300	755712 ■ FL-07000	755719 ■ FL-10300	755725 ■ FL-07000	755731 ■ FL-06200								
			STRUTTURATO	-	755737 ■ FL-07000	-	-	-								
				6 mm 1/4" ↑↓		120x280 47 1/4" x 110 1/4"		120x240 47 1/4" x 94 1/2"		120x120 47 1/4" x 47 1/4"		60x120 23 5/8" x 47 1/4"				
MATIÈRES		MATIÈRES SABLE	MATTE	757641 ■ FL-12400	756119 ■ FL-11300	756123 ■ FL-09700	756127 ■ FL-09100									
			R+PTV	-	758811 ■ FL-11300	757645 ■ FL-09700	-									
		MATIÈRES MOU	MATTE	757644 ■ FL-12400	756122 ■ FL-11300	756126 ■ FL-09700	756130 ■ FL-09100									
			R+PTV	-	758814 ■ FL-11300	757648 ■ FL-09700	-									

MATIÈRES NUAGE



MATIÈRES GRIS



V3
R10
 (matte)
 CLASSE
 A+B

R11
 (strutturato)
 CLASSE
 A+B+C

DCOF>
 0,42 Wet

9 mm 3/8" ↑↓



V3
R9
 (matte)
 CLASSE A

R10
 (R+PTV)
 CLASSE
 A+B

BS EN 16165
 ANNEX C
 >36 wet
 slider 4S

DCOF>
 0,42 Wet





6 mm 1/4" ↑↓

FLOHM OVERSIZE
magnUm

GRES FINE PORCELLANATO

FINE PORCELAIN STONEWARE/GRES CERAME FIN/FEINSTEINZEUG-KOLLEKTIONEN/GRES PORCELANICO FINO

SQUADRATO - SQUARED - EQUARRI - REKTIFIZIERT - ESCUADRADO

				9 mm 3/8" ↑↓		80x80 31 1/2" x 31 1/2"		40x80 15 3/4" x 31 1/2"		60x120 23 5/8" x 47 1/4"		60x60 23 5/8" x 23 5/8"		30x60 11 5/8" x 23 5/8"		
		COLOR	SURFACE													
MATIÈRES		MATIÈRES NUAGE	MATTE	755708 ■ FL-09300	755714 ■ FL-07000	755721 ■ FL-10300	755727 ■ FL-07000	755733 ■ FL-06200								
			STRUTTURATO	-	755739 ■ FL-07000	-	-	-								
		MATIÈRES GRIS	MATTE	755707 ■ FL-09300	755713 ■ FL-07000	755720 ■ FL-10300	755726 ■ FL-07000	755732 ■ FL-06200								
			STRUTTURATO	-	755738 ■ FL-07000	-	-	-								
				6 mm 1/4" ↑↓		120x280 47 1/4" x 110 1/4"		120x240 47 1/4" x 94 1/2"		120x120 47 1/4" x 47 1/4"		60x120 23 5/8" x 47 1/4"				
MATIÈRES		MATIÈRES NUAGE	MATTE	757642 ■ FL-12400	756120 ■ FL-11300	756124 ■ FL-09700	756128 ■ FL-09100									
			R+PTV	-	758812 ■ FL-11300	757646 ■ FL-09700	-									
		MATIÈRES GRIS	MATTE	757643 ■ FL-12400	756121 ■ FL-11300	756125 ■ FL-09700	756129 ■ FL-09100									
			R+PTV	-	758813 ■ FL-11300	757647 ■ FL-09700	-									

MATIÈRES

MATIÈRES BRUN



MATIÈRES BARRIQUE



V3

R10
(matte)
CLASSE
A+B

R11
(strutturato)
CLASSE
A+B+C

DCOF >
0,42 Wet

9 mm 3/8" ↑↓

GRES FINE PORCELLANATO

FINE PORCELAIN STONEWARE/GRES CERAME FIN/FEINSTEINZEUG-KOLLEKTIONEN/GRES PORCELANICO FINO
SQUADRATO - SQUARED - EQUARRI - REKTIFIZIERT - ESCUADRADO

9 mm 3/8" ↑↓

		COLOR	SURFACE	80x80 31 ^{1/2} "x31 ^{1/2} "	40x80 15 ^{3/4} "x31 ^{1/2} "	60x120 23 ^{5/8} "x47 ^{1/4} "	60x60 23 ^{5/8} "x23 ^{5/8} "	30x60 11 ^{4/5} "x23 ^{5/8} "
MATIÈRES	■	MATIÈRES BRUN	MATTE	755709 ■ FL-09300	755715 ■ FL-07000	755722 ■ FL-10300	755728 ■ FL-07000	755734 ■ FL-06200
			STRUTTURATO	-	755740 ■ FL-07000	-	-	-
	■	MATIÈRES BARRIQUE	MATTE	755710 ■ FL-09300	755716 ■ FL-07000	755723 ■ FL-10300	755729 ■ FL-07000	755735 ■ FL-06200
			STRUTTURATO	-	755741 ■ FL-07000	-	-	-

MATIÈRES SABLE



MATIÈRES NUAGE



R11
(strutturato)
CLASSE
A+B+C

DCOF>
0,42 Wet

20 mm 3/4" ↑↓

MATIÈRES GRIS



MATIÈRES MOU



GRES FINE PORCELLANATO
FINE PORCELAIN STONWARE/GRES CERAME FIN/FEINSTEINZEUG-KOLLEKTIONEN/GRES PORCELANICO FINO

	20 mm 3/4" ↑↓	COLOR	SURFACE	20,2x20,2 8"x8"	20,2x30,4 8"x12"
MATIÈRES		MATIÈRES SABLE	STRUTTURATO	755742 ■ FL-10800	755748 ■ FL-10800
		MATIÈRES NUAGE	STRUTTURATO	755745 ■ FL-10800	755751 ■ FL-10800
		MATIÈRES GRIS	STRUTTURATO	755744 ■ FL-10800	755750 ■ FL-10800
		MATIÈRES MOU	STRUTTURATO	755743 ■ FL-10800	755749 ■ FL-10800



Recycled material content certification

ISO 10545-4	RESISTENZA ALLA FLESSIONE IN N/mm ² N/mm ² FLEXURAL STRENGTH TEST / RESISTANCE A LA FLEXION EN N/mm ² / BIEGEFESTIGKEIT IN N/mm ² / RESISTENCIA A LA FLEXION EN N/mm ²	valore medio 52 N/mm ²
	Forza di rottura in N (ep. > 7,5 mm) Breaking strength in N (ep. > 7,5 mm) / Force de rupture en N (ep. > 7,5 mm) / Bruchlast in N (Dicke > 7,5 mm) / Fuerza de rotura en N (es. > 7,5 mm)	valore medio 14000 N

MATIÈRES	scatola - box			pallet		
	pz	mq	kg	box	mq	kg
20,2x20,2 20mm	12	0,49	21,88	54	26,46	1210
20,2x30,4 20mm	7	0,43	19,20	60	25,80	1180

Material non esattamente calibrato; prevedere fuga da 3 a 7 mm. / Calibration of this product is not exact, please consider a 3 to 7 mm joint. / Matériel non calibré de manière précise; prévoir un joint de 3 à 7 mm. / Nicht exakt rektifiziertes Material, es muss eine Fuge von 3-7mm vorgesehen werden. / Material no exactamente calibrado; prever una junta de 3 a 7mm.

MATIÈRES OUTDOOR

Vantaggi tecnici - Technical advantages - Avantages techniques Technische Vorteile - Ventajas técnicas

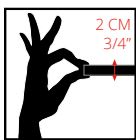

- Lastra monolitica compatta di spessore 2 cm squadrata e rettificata
- Compact monolithic slab 2 cm thick squared and rectified
- Dalle monolithique compacte de 2 cm d'épaisseur, équarrie et rectifiée
- Kompakte monolithische Platte, 2 cm dick, rechteckig und scharfkantig geschliffen
- Losa monolítica compacta de 2 cm de espesor, escuadrada y rectificada.

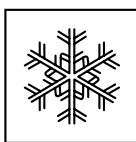

- INGELIVO
- FROST RESISTANT
- INGÉLIF
- FROSTBESTÄNDIG
- RESISTENTE A LA HELADA

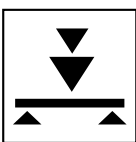

- ELEVATA RESISTENZA AI CARICHI STATICI
- HIGH STATIC LOAD RESISTANCE
- RÉSISTANCE ÉLEVÉE AUX CHARGES STATIQUES
- HOHE STATISCHE BELASTBARKEIT
- ELEVADA RESISTENCIA A LAS CARGAS ESTÁTICAS

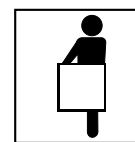

- FACILE DA POSARE
- EASY TO INSTALL
- FACILE À POSER
- VERLEGELEICHT
- FÁCIL DE COLOCAR



- ANTISCIVOLO R11
- ANTI SLIP R11
- ANTIDÉRAPANT R11
- RUTSCHFEST R11
- ANTIDESLIZANTE R11

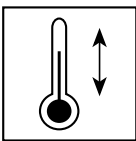

- RESISTENTE AGLI SBALZI TERMICI
- THERMAL SHOCK RESISTANT
- RÉSISTANT AUX ÉCARTS THERMIQUES
- TEMPERATURWECHSELBESTÄNDIG
- RESISTENTE A LAS OSCILACIONES TÉRMICAS



- FACILE DA PULIRE
- EASY TO CLEAN
- FACILE À NETTOYER
- REINIGUNGSLEICHT
- FÁCIL DE LIMPIAR

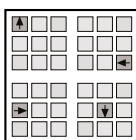

- RIMOVIBILE E RIUTILIZZABILE
- REMOVABLE AND REUSABLE
- DÉMONTABLE ET RÉUTILISABLE
- ENTFERNBAR UND WIEDERVERWENDBAR
- DESMONTABLE Y REUTILIZABLE



- INATTACCABILE DA AGENTI CHIMICI E MUFFE
- IMPERVIOUS TO ATTACK BY CHEMICALS OR MOULD
- RÉSISTANT AUX AGENTS CHIMIQUES ET AUX MOISSISURES
- UNANGREIFBAR DURCH CHEMISCHE STOFFE UND SCHIMMEL
- RESISTENTE A LOS AGENTES QUÍMICOS Y A LOS MOHOS

Applicazioni - Applications - Applications - Verlegung - Aplicaciones

- Posa diretta su erba
- Direct installation on grass
- Pose direct sur de l'herbe
- Verlegung direkt auf Rasen
- Colocación directa sobre hierba



- Posa diretta su ghiaia
- Direct installation over gravel
- Pose direct sur du gravier
- Verlegung direkt auf Kies
- Colocación directa sobre grava



- Posa su massetto cementizio
- Installation on sand-cement screed
- Pose sur chape ciment
- Verlegung auf Zement-Unterbetonblock
- Colocación sobre contrapiso de hormigón

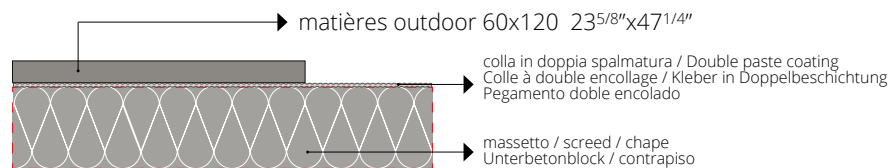

- Posa su piedini fissi o regolabili
- Installation on fixed or adjustable feet
- Pose sur pieds fixes ou réglables
- Verlegung auf feststehende oder regulierbare Füße
- Colocación sobre pies fijos o regulables

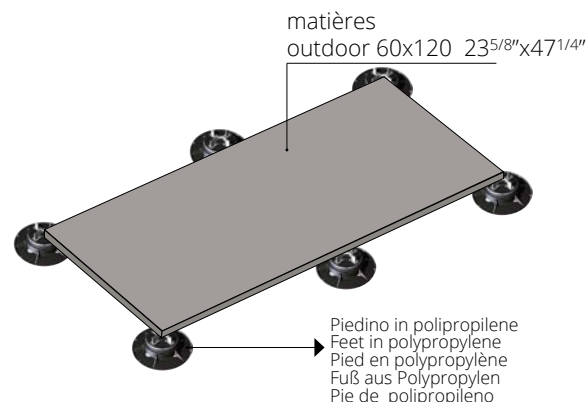

Per le specifiche di utilizzo dei sistemi sopraelevati vedi il sito florim.com
For the specifics on use of raised systems visit the site florim.com
Pour les caractéristiques d'utilisation des systèmes surélevés, voir le site florim.com
Für die Nutzungsbedingungen der Doppelbodensysteme siehe Webseite florim.com
Para las especificaciones de empleo de los sistemas sobreelevados consulte el sitio web florim.com

Le lastre ceramiche sono sottoposte a un trattamento di compattazione termica che assicura resistenza e durata nel tempo. Il bassissimo assorbimento d'acqua rende perciò il materiale ingelivo. Ciò può comportare ristagni d'acqua superficiali anche per materiale installato a regola d'arte. / Ceramic tiles undergo a compacting thermal treatment that ensures resistance and durability. The low level of water absorption makes the slabs frost resistant. This could result in superficial water stagnations even if materials are installed in a workmanlike manner. / Les carreaux de céramique subissent un traitement thermique de compactage qui assure résistance et durabilité. Le bas niveau d'absorption d'eau rend les dalles résistant au gel. Il pourrait en résulter des stagnations d'eau superficielles, même si les dalles ont été installées dans les règles de l'art. / Die Keramikplatten werden einer thermischen Verdichtung unterzogen, welche die Widerstandsfähigkeit und Langlebigkeit sichert. Die extrem niedrige Wasseraufnahme macht das Material frostsicher. Die hohe Materialdichte kann, auch bei einer perfekten Verlegung, eine längere Abtrochnungszeit von angestaumtem Wasser zur Folge haben. / Las baldosas cerámicas se someten a un tratamiento de compactación térmica que asegura resistencia y durabilidad. La baja absorción de agua hace que las baldosas resistan al hielo. Esto podría resultar en estancamientos superficiales de agua, incluso si los materiales están instalados según las reglas del arte.

MATIÈRES SABLE



MATIÈRES NUAGE



R11
(strutturato)
CLASSE
A+B+C

DCOF>
0,42 Wet

20 mm 3/4" ↑↓

MATIÈRES BRUN



GRES FINE PORCELLANATO

FINE PORCELAIN STONEWARE/GRES CERAME FIN/FEINSTEINZEUG-KOLLEKTIONEN/GRES PORCELANICO FINO
SQUADRATO - SQUARED - EQUARRI - REKTIFIZIERT - ESCUADRADO

	20 mm 3/4" ↑↓	COLOR	SURFACE	60x120 23 ^{5/8"} x47 ^{1/4"}
MATIÈRES		MATIÈRES SABLE	STRUTTURATO	768518 ■ FL-11300
		MATIÈRES NUAGE	STRUTTURATO	768517 ■ FL-11300
		MATIÈRES BRUN	STRUTTURATO	768516 ■ FL-11300



Recycled material content certification







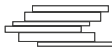

ISO 10545-4	RESISTENZA ALLA FLESSIONE IN N/mm ² N/mm ² FLEXURAL STRENGTH TEST / RESISTANCE A LA FLEXION EN N/mm ² / BIEGEFESTIGKEIT IN N/mm ² / RESISTENCIA A LA FLEXION EN N/mm ²	valore medio 52 N/mm ²
	Forza di rottura in N (ep. > 7,5 mm) Breaking strength in N (thickness > 7,5 mm) / Force de rupture en N (ep. > 7,5 mm) / Bruchlast in N (Dicke > 7,5 mm) / Fuerza de rotura en N (gr. > 7,5 mm)	valore medio 14000 N

PEZZI SPECIALI

Special trims/Pièces spéciales
Formstücke/Piezas especiales
pag 194/197









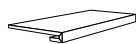

MATIÈRES	scatola - box			pallet		
	pz	mq	kg	box	mq	kg
60x120 20mm	1	0,72	32,26	30	21,60	1000

MATIÈRES

9 mm 3/8" ↑↓	COLOR	SURFACE	30x30 11 ^{4/5"} x11 ^{4/5"}	21x40 8 ^{1/4"} x15 ^{3/4"}	30x30 11 ^{4/5"} x11 ^{4/5"}
			 mosaico tessere 5x5 pz/box 11	 modulo listello sfalsato pz/box 5	 modulo muretto 3D pz/box 6
	MATIÈRES SABLE	MATTE	755930 ▲ FL-01500	755936 ▲ FL-01900	755942 ▲ FL-03600
	MATIÈRES MOU	MATTE	755931 ▲ FL-01500	755937 ▲ FL-01900	755943 ▲ FL-03600
	MATIÈRES NUAGE	MATTE	755933 ▲ FL-01500	755939 ▲ FL-01900	755945 ▲ FL-03600
	MATIÈRES GRIS	MATTE	755932 ▲ FL-01500	755938 ▲ FL-01900	755944 ▲ FL-03600
	MATIÈRES BRUN	MATTE	755934 ▲ FL-01500	755940 ▲ FL-01900	755946 ▲ FL-03600
	MATIÈRES BARRIQUE	MATTE	755935 ▲ FL-01500	755941 ▲ FL-01900	755947 ▲ FL-03600

MATIÈRES

PEZZI SPECIALI/SPECIAL TRIMS/PIÈCES SPÉCIALES/FORMSTÜCKE/PIEZAS ESPECIALES

9 mm 3/8" ↑↓	COLOR	SURFACE	4,6x60 1 ^{4/5"} x23 ^{5/8"}	15x30x4 6"x11 ^{4/5"} x1 ^{4/7"}	33x120x3 13"x47 ^{1/4"} x1 ^{1/8"}	33x120x3 13"x47 ^{1/4"} x1 ^{1/8"}	33x120x3 13"x47 ^{1/4"} x1 ^{1/8"}
			 battiscopa	 elemento elle strutturato pz/box 6	 gradino pz/box 2	 angolo gradino dx pz/box 2	 angolo gradino sx pz/box 2
	MATIÈRES SABLE	MATTE	755948 ◆ FL-01600	755954 ▲ FL-02400	755960 ▲ FL-20400	755966 ▲ FL-31100	755972 ▲ FL-31100
	MATIÈRES MOU	MATTE	755949 ◆ FL-01600	755955 ▲ FL-02400	755961 ▲ FL-20400	755967 ▲ FL-31100	755973 ▲ FL-31100
	MATIÈRES NUAGE	MATTE	755951 ◆ FL-01600	755957 ▲ FL-02400	755963 ▲ FL-20400	755969 ▲ FL-31100	755975 ▲ FL-31100
	MATIÈRES GRIS	MATTE	755950 ◆ FL-01600	755956 ▲ FL-02400	755962 ▲ FL-20400	755968 ▲ FL-31100	755974 ▲ FL-31100
	MATIÈRES BRUN	MATTE	755952 ◆ FL-01600	755958 ▲ FL-02400	755964 ▲ FL-20400	755970 ▲ FL-31100	755976 ▲ FL-31100
	MATIÈRES BARRIQUE	MATTE	755953 ◆ FL-01600	755959 ▲ FL-02400	755965 ▲ FL-20400	755971 ▲ FL-31100	755977 ▲ FL-31100

MATIÈRES

MATIÈRES	scatola - box			pallet		
	pz	mq	kg	box	mq	kg
80x80	2	1,28	24,96	40	51,20	1030
40x80	3	0,96	18,53	56	53,76	1070
60x120	2	1,44	28,08	30	43,20	870
60x60	3	1,08	21,06	40	43,20	870
30x60	6	1,08	20,84	40	43,20	860

9 mm 3/8" ↑↓

Product Certification
BUREAU VERITAS
Certification

Recycled material content certification



MATIÈRES	scatola - box			pallet		
	pz	ml	kg	box	mq	kg
4,6x60 battiscopa	14	8,40	8,40	-	-	-

6 mm 1/4"				30x30 11 ^{4/5"} x11 ^{4/5"}	30x30 11 ^{4/5"} x11 ^{4/5"}	30x30 11 ^{4/5"} x11 ^{4/5"}
	COLOR	SURFACE		mosaico tessere 7,5x7,5 pz/box 11	muretto tessere 7,5x15 pz/box 11	mosaico tessere 1,5x3 pz/box 11
MATIÈRES	MATIÈRES SABLE	MATTE	755978 ▲ FL-01800	755984 ▲ FL-01800	755990 ▲ FL-02700	
	MATIÈRES MOU	MATTE	755979 ▲ FL-01800	755985 ▲ FL-01800	755991 ▲ FL-02700	
	MATIÈRES NUAGE	MATTE	755981 ▲ FL-01800	755987 ▲ FL-01800	755993 ▲ FL-02700	
	MATIÈRES GRIS	MATTE	755980 ▲ FL-01800	755986 ▲ FL-01800	755992 ▲ FL-02700	

PEZZI SPECIALI/SPECIAL TRIMS/PIÈCES SPÉCIALES/FORMSTÜCKE/PIEZAS ESPECIALES

6 mm 1/4"				4,6x60 1 ^{4/5"} x23 ^{5/8"}
	COLOR	SURFACE		battiscopa
MATIÈRES	MATIÈRES SABLE	MATTE	755996 ◆ FL-01800	
	MATIÈRES MOU	MATTE	755997 ◆ FL-01800	
	MATIÈRES NUAGE	MATTE	755999 ◆ FL-01800	
	MATIÈRES GRIS	MATTE	755998 ◆ FL-01800	

Per un effetto ottimale della posa, florim suggerisce di mantenere 2 mm di fuga per pose monoformato e 3 mm per combinare formati misti - For optimal installation results, florim recommends maintaining a joint of 2 mm 1/12" for single format installations and 3 mm 1/8" to combine mixed formats. - Pour réaliser une pose parfaite, florim suggère de maintenir 2 mm de joint pour la pose des monoformats, et 3 mm pour les combinaisons de formats mixtes. - Um einen optimalen effekt beim verlegen zu erzielen empfiehlt florim eine 2 mm fugе bei einformatigen verlegungen und 3 mm fugе bei formatkombinationen Para lograr los máximos resultados en la posa del producto, florim aconseja 2 mm de junta en aplicaciones monoformato y 3 mm en combinaciones de formatos mixtos

In relazione alle differenti tecnologie produttive l'accostamento di prodotti con spessori diversi potrebbe presentare delle disomogeneità, se ne sconsiglia pertanto l'abbinamento. Due to the different production technologies, contiguous installation of products with different thickness may give a non-homogeneous result. For this reason we do not recommend this option. / Vu que différentes technologies de production sont utilisées avec des épaisseurs différentes, des problèmes d'homogénéité pourraient se présenter, il est donc déconseillé de les poser ensemble. / Wegen unterschiedlicher Produktionstechnologien können die Fliesen mit verschiedenen Materialstärken optische Differenzen aufweisen. Von einem direkten Aneinanderlegen wird deshalb abgeraten. / Dadas las diferentes tecnologías productivas, la combinación de productos de diferentes espesores podría dar lugar a heterogeneidad, por lo que se desaconseja mezclarlas.

FLORIM OVERSIZE
magnUm

120x280/120x240/120x120/60x120

Specifica Imballo pag.
Packaging specifications on page
Spécifications d'emballage à page
Verpackungsdetail Seite
Especificaciones de embalaje a la página
204/205

I formati 160x160 e 80x240 posso essere acquistati solo a multipli di 2 lastre. / Sales unit for 160x160 and 80x240 is 2 pcs, so they can only be bought in multiples of 2. / Les formats 160x160 et 80x240 sont vendus par multiples de 2 plaques / Die Formate 160x160 und 80x240 können nur in einer durch 2 teilbaren Anzahl bestellt werden / Las medidas 160x160 y 80x240 solo pueden comprarse en múltiplos de 2 placas



PLANCHES

gres fine porcellanato
fine porcelain stoneware
grès cérame fin
feinsteinzeug-kollektionen
gres porcelánico fino





PLANCHES

Planches rappresenta lo stato dell'arte e fissa un nuovo punto di riferimento per il gres porcellanato ispirato alla estetica del legno, una tipologia tra le più apprezzate dal mercato. L'assortimento di formati è decisamente ai vertici, con doghe della misura ideale per spazi prestigiosi o raccolti; la gamma di colori originali e moderni è stata accuratamente studiata per intonarsi con materiali e nuances di tendenza nell'interior design contemporaneo.

Planches sets a new benchmark for the porcelain tile interpretation of natural wood, currently one of the most prized types of ceramic. The collection has an unbeatable variety of formats, with slats of the ideal size for prestigious, discreet settings; its modern, original colours have been carefully selected to match the trends of contemporary interior design.

Planches utilise les dernières technologies disponibles et représente une nouvelle référence pour le grès cérame inspiré de l'esthétique du bois, un type de produits parmi les plus appréciés du marché. L'assortiment de formats est conforme aux meilleurs standards et propose des lames de dimensions idéales pour des espaces prestigieux ou concentrés; la gamme de couleurs originales et modernes a été soigneusement étudiée pour s'adapter aux nuances et aux matériaux actuellement utilisés dans l'aménagement intérieur.

Planches repräsentiert den Stand der Technik und legt einen neuen Bezugspunkt für das Feinsteinzeug fest, inspiriert von der Ästhetik des Holzes, eine vom Markt am meisten geschätzte Typologie. Das Sortiment der Formate ist unverkennbar führend, mit Dauben in der idealen Größe für bedeutende oder ruhige Räumlichkeiten; das Spektrum von originellen und modernen Farben wurde sorgfältig durchdacht, um sich den modischen Materialien und Nuancen der zeitgemäßen Innenraumgestaltung anzupassen.

Planches representa la vanguardia y fija un nuevo punto de referencia para el gres porcelánico inspirado en la estética de la madera, una tipología de las más apreciadas del mercado. La variedad de formatos destaca sin lugar a duda, con láminas de la medida ideal para espacios prestigiosos o recogidos; la gama de colores originales y modernos ha sido cuidadosamente estudiada para entonarse con materiales y tonos de tendencia dentro del diseño contemporáneo.

PLANCHES

AMANDE



MIEL



R10
(matte)

R11
(strutturato)



CLASSE
A+B
(matte/
strutturato)

DCOF >
0,42 Wet

9 mm 3/8" ↑↓

GRES FINE PORCELLANATO

FINE PORCELAIN STONEWARE/GRES CERAME FIN/FEINSTEINZEUG-KOLLEKTIONEN/GRES PORCELANICO FINO
SQUADRATO - SQUARED - EQUARRI - REKTIFIZIERT - ESCUADRADO

9 mm 3/8" ↑↓		COLOR	SURFACE	26,5x180 10 ^{3/7"} x70 ^{6/7"}	20x180 7 ^{7/8"} x70 ^{6/7"}	20x120 7 ^{7/8"} x47 ^{1/4"}	15x120 6"x47 ^{1/4"}
PLANCHES		AMANDE	MATTE	755693 ■ FL-09900	755698 ■ FL-09900	755608 ■ FL-07700	755666 ■ FL-07700
			STRUTTURATO	-	-	755671 ■ FL-07700	-
		MIEL	MATTE	755694 ■ FL-09900	755699 ■ FL-09900	755609 ■ FL-07700	755667 ■ FL-07700
			STRUTTURATO	-	-	755672 ■ FL-07700	-

NOISETTE



PERLE



V3

R10
(matte)

R11
(strutturato)



CLASSE
A+B
(matte/
strutturato)

DCOF>
0,42 Wet

9 mm 3/8" ↑↓

GRES FINE PORCELLANATO

FINE PORCELAIN STONEWARE/GRES CERAME FIN/FEINSTEINZEUG-KOLLEKTIONEN/GRES PORCELANICO FINO
SQUADRATO - SQUARED - EQUARRI - REKTIFIZIERT - ESCUADRADO

9 mm 3/8" ↑↓		COLOR	SURFACE	26,5x180 10 ^{3/16"} x70 ^{5/16"}	20x180 7 ^{7/8"} x70 ^{5/16"}	20x120 7 ^{7/8"} x47 ^{1/4"}	15x120 6"x47 ^{1/4"}
PLANCHES		NOISETTE	MATTE	755696 ■ FL-09900	755702 ■ FL-09900	755611 ■ FL-07700	755669 ■ FL-07700
			STRUTTURATO	-	-	755674 ■ FL-07700	-
		PERLE	MATTE	755695 ■ FL-09900	755701 ■ FL-09900	755610 ■ FL-07700	755668 ■ FL-07700
			STRUTTURATO	-	-	755673 ■ FL-07700	-

PLANCHES

CHOCO



V3
R10
 (matte)

R11
 (strutturato)

CLASSE
 A+B
 (matte/
 strutturato)

DCOF>
 0,42 Wet

9 mm 3/8" ↑↓

GRES FINE PORCELLANATO

FINE PORCELAIN STONEWARE/GRES CERAME FIN/FEINSTEINZEUG-KOLLEKTIONEN/GRES PORCELANICO FINO
 SQUADRATO - SQUARED - EQUARRI - REKTIFIZIERT - ESCUADRADO

9 mm 3/8" ↑↓		COLOR	SURFACE	26,5x180 10 ^{3/8"} x70 ^{5/7"}	20x180 7 ^{7/8"} x70 ^{5/7"}	20x120 7 ^{7/8"} x47 ^{1/4"}	15x120 6"x47 ^{1/4"}
PLANCHES		CHOCO	MATTE	755697 ■ FL-09900	755703 ■ FL-09900	755612 ■ FL-07700	755670 ■ FL-07700
			STRUTTURATO	-	-	755675 ■ FL-07700	-

9 mm 3/8" 

COLOR

SURFACE

80x80
31^{1/2"}x31^{1/2"}



D COR AMANDE

MATTE

755687
■ FL-10500



D COR MIEL

MATTE

755688
■ FL-10500

PLANCHES



D COR NOISETTE

MATTE

755690
■ FL-10500



D COR PERLE

MATTE

755689
■ FL-10500



D COR CHOCO

MATTE

755691
■ FL-10500

PLANCHES

9 mm 3/8" ↑↓				30x30 11 ^{4/5"} x11 ^{4/5"}	15x45 6"x17 ^{3/7"}
	COLOR	SURFACE		modulo listello tessere 7,5x30 pz/box 6	modulo listello sfalsato pz/box 6
PLANCHES	AMANDE	MATTE		756077 ▲ FL-01160	756082 ▲ FL-02300
	MIEL	MATTE		756078 ▲ FL-01160	756083 ▲ FL-02300
	NOISETTE	MATTE		756080 ▲ FL-01160	756085 ▲ FL-02300
	PERLE	MATTE		756079 ▲ FL-01160	756084 ▲ FL-02300
	CHOCO	MATTE		756081 ▲ FL-01160	756086 ▲ FL-02300

PEZZI SPECIALI/SPECIAL TRIMS/PIÈCES SPÉCIALES/FORMSTÜCKE/PIEZAS ESPECIALES

9 mm 3/8" ↑↓				4,6x60 1 ^{4/5"} x23 ^{3/8"}	15x30x4 6"x11 ^{4/5"} x1 ^{4/7"}	40x120x3 15 ^{3/4"} x47 ^{1/4"} x1 ^{1/8"}	40x120x3 15 ^{3/4"} x47 ^{1/4"} x1 ^{1/8"}	40x120x3 15 ^{3/4"} x47 ^{1/4"} x1 ^{1/8"}	40x120x3 15 ^{3/4"} x47 ^{1/4"} x1 ^{1/8"}
	COLOR	SURFACE		battiscopa	elemento elle strutturato pz/box 4	gradino pz/box 2	angolo gradino DX pz/box 2	angolo gradino SX pz/box 2	angolo gradino DX/SX pz/box 1
PLANCHES	AMANDE	MATTE		756087 ◆ FL-01600	756092 ▲ FL-03600	756097 ▲ FL-21000	756102 ▲ FL-31100	756107 ▲ FL-31100	756112 ▲ FL-42900
	MIEL	MATTE		756088 ◆ FL-01600	756093 ▲ FL-03600	756098 ▲ FL-21000	756103 ▲ FL-31100	756108 ▲ FL-31100	756113 ▲ FL-42900
	NOISETTE	MATTE		756090 ◆ FL-01600	756095 ▲ FL-03600	756100 ▲ FL-21000	756105 ▲ FL-31100	756110 ▲ FL-31100	756115 ▲ FL-42900
	PERLE	MATTE		756089 ◆ FL-01600	756094 ▲ FL-03600	756099 ▲ FL-21000	756104 ▲ FL-31100	756109 ▲ FL-31100	756114 ▲ FL-42900
	CHOCO	MATTE		756091 ◆ FL-01600	756096 ▲ FL-03600	756101 ▲ FL-21000	756106 ▲ FL-31100	756111 ▲ FL-31100	756116 ▲ FL-42900

Product Certification
BUREAU VERITAS
Certification



Recycled material content certification

Nelle operazioni di posa a listoni sfalsati, si raccomanda sempre di fare in modo che il lato maggiore della piastrina termini a circa un terzo della lunghezza di quelle accanto (posa sfalsata "a 1/3"). - When installing staggered strips, we recommend that the tile's longer side should always end at about one-third of the length of the tiles next to it ("1/3" staggered installation). - Lors de la pose des listels décalés, il faut toujours faire en sorte que le côté le plus grand du carreau se trouve à environ 1/3 de la longueur des carreaux d'à côté (pose décalée "à 1/3"). - Beim Verlegen der Leisten in versetzter Form ist zu beachten, dass die höhere Seite der Fliese immer circa bei einem Drittel der Länge der sich daneben befindlichen Fliesen abschließt ("Um 1/3" versetzte Verlegung). - En las operaciones de colocación de listones escalonados, se recomienda hacerlo siempre de forma tal que el lado mayor del azulejo termine teniendo alrededor de un tercio de la longitud de los contiguos (colocación escalonada "a 1/3").

Per un effetto ottimale della posa, florim suggerisce di mantenere 2 mm di fuga per pose monoformato e 3 mm per combinare formati misti. - For optimal installation results, florim recommends maintaining a joint of 2 mm 1/12" for single format installations and 3 mm 1/8" to combine mixed formats. - Pour réaliser une pose parfaite, florim suggère de maintenir 2 mm de joint pour la pose des monoformats, et 3 mm pour les combinaisons de formats mixtes. - Um einen optimalen effekt beim verlegen zu erzielen empfiehlt florim eine 2 mm fuge bei einformatigen verlegungen und 3 mm fuge bei formatkombinationen. Para lograr los máximos resultados en la posa del producto, florim aconseja 2 mm de junta en aplicaciones monoformato y 3 mm en combinaciones de formatos mixtos.

PLANCHES	scatola - box			pallet		
	pz	mq	kg	box	mq	kg
26,5x180	3	1,44	28,80	42	60,48	1270
20x180	4	1,44	33,12	40	57,60	1380
20x120	6	1,44	28,08	24	34,56	700
15x120	6	1,08	24,08	32	34,56	800

PLANCHES	scatola - box			pallet		
	pz	ml	kg	box	mq	kg
4,6x60 battiscopa	14	8,40	8,40	-	-	-





PREXIOUS

gres porcellanato colorato in massa
coloured body porcelain stoneware
grès cérame colore dans la masse
durchgefärbte feinsteinzeug
gres porcelánico coloreado en masa





PREXIOUS

Simbolo di bellezza e indiscussa regina delle superfici, l'estetica del marmo trova inedite interpretazioni nella nuova collezione **Prexious**. Partendo dalla ricerca di esemplari lapidei rari e preziosi, i cromatismi e le venature sono stati rielaborati e reinterpretati con perizia tecnica e creatività, trasformandoli in creazioni originali di grande suggestione, che esprimono appieno il gusto inimitabile di Luxury design. Lo sviluppo armonioso del disegno che si rivela accostando le lastre in ampie superfici è un fattore di distinzione, così come le pregiate finiture di superficie, lucida e brillante o delicatamente satinata.

The pinnacle of elegance and undisputed queen of covering materials, marble is given new life in the **Prexious** collection. Starting from carefully selected, rare examples of marble, the colours and veining have been re-interpreted with all of Luxury design technical skill and creativity, and transformed into highly evocative panels of inimitable elegance. The design was conceived to reveal harmonious patterns when the panels are placed next to each other over large surfaces, as do the textures, whether brilliant gloss or delicately satin-finished.

Incarnation de la beauté et reine incontestable des surfaces, l'esthétique du marbre est interprétée de manière inédite dans la nouvelle collection **Prexious**. À partir de la recherche de pierres rares et précieuses, les effets chromatiques et les marbrures, réélaborés et réinterprétés de manière créative avec un grand savoir-faire technique, ont été transformés en créations originales d'une grande beauté, qui expriment pleinement le style inimitable de Luxury design. Le développement harmonieux des motifs, qui se révèle en disposant les dalles côte à côte sur de grandes surfaces, est un facteur de distinction, à l'instar des belles finitions de surface, brillante ou délicatement satinée.

Symbol für Schönheit und unbestrittene Königin der Oberflächen findet die Ästhetik des Marmors ungewöhnliche Interpretationen in der neuen Kollektion **Prexious**. Ausgehend von der Suche nach seltenen und wertvollen Steinexemplaren, wurden die Chromatik und die Äderungen mit technischer Fachkenntnis und Kreativität neu verarbeitet und neu interpretiert und so in originelle Realisierungen von großem Charme verwandelt, die voll den unnachahmlichen Geschmack von Luxury design ausdrücken. Der harmonische Verlauf des Musters, der sich beim Zusammenfügen der Platten auf großen Flächen zeigt, stellt ein Unterscheidungsmerkmal dar, wie auch die wertvollen Oberflächenbearbeitungen: glänzend und brillant oder fein satiniert.

La estética del mármol, símbolo de belleza y reina indiscutible de las superficies, encuentra interpretaciones inéditas en la nueva colección **Prexious**. Partiendo de la búsqueda de ejemplares lapídeos raros y preciados, los cromatismos y las vetas han sido reelaborados y reinterpretados con habilidad técnica y creatividad, transformándolos en creaciones originales de gran sugestión que expresan por completo el gusto inimitable de Luxury design. El desarrollo armonioso del diseño que se revela combinando las losas en amplias superficies es un factor de distinción, así como los preciados acabados de la superficie, reluciente y brillante o delicadamente satinada.

PREXIOUS

WHITE FANTASY



MOUNTAIN TREASURE

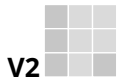

V2
DCOF>
0,42 Wet
(matte)

9 mm 3/8" ↑↓

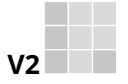

V2
DCOF>
0,42 Wet
(matte)

6 mm 1/4" ↑↓

FLORIM OVERSIZE
magnUlm

GRES PORCELLANATO COLORATO IN MASSA/COLOURED BODY PORCELAIN STONWARE
GRÈS CÉRAME COLORE DANS LA MASSE/DURCHGEFÄRBTE FEINSTEINZEUG/GRES PORCELÁNICO COLOREADO EN MASA
SQUADRATO - SQUARED - EQUARRI - REKTIFIZIERT - ESCUADRADO

		9 mm 3/8" ↑↓		80x180 31 1/2" x 70 5/8"		80x80 31 1/2" x 31 1/2"		60x120 23 5/8" x 47 1/4"		60x60 23 5/8" x 23 5/8"		30x60 11 4/5" x 23 5/8"					
	COLOR	SURFACE															
PREXIOUS	WHITE FANTASY	GLOSSY	755815 ■ FL-11900	755827 ■ FL-10800	755843 ■ FL-11300	755867 ■ FL-09100	755880 ■ FL-07700										
		MATTE	755809 ■ FL-10500	755821 ■ FL-09300	755833 ■ FL-09900	755861 ■ FL-07300	755873 ■ FL-06200										
	MOUNTAIN TREASURE	GLOSSY	755816 ■ FL-11900	755828 ■ FL-10800	755844 ■ FL-11300	755868 ■ FL-09100	755881 ■ FL-07700										
		MATTE	755810 ■ FL-10500	755822 ■ FL-09300	755834 ■ FL-09900	755862 ■ FL-07300	755875 ■ FL-06200										
		6 mm 1/4" ↑↓		160x320 63" x 126"		120x280 47 1/4" x 110 1/4"		160x160 63" x 63"		120x240 47 1/4" x 94 1/4"		120x120 47 1/4" x 47 1/4"		80x80 31 1/2" x 31 1/2"		60x120 23 5/8" x 47 1/4"	
PREXIOUS	WHITE FANTASY	GLOSSY	756424 ■ FL-18800	757735 ■ FL-15100	756436 ■ FL-16100	756285 ■ FL-14000	756388 ■ FL-12400	756412 ■ FL-10300	756400 ■ FL-11300								
		MATTE	756418 ■ FL-15600	757729 ■ FL-12400	756430 ■ FL-13400	756290 ■ FL-11300	756382 ■ FL-09700	756406 ■ FL-08400	756394 ■ FL-09100								

PEARL ATTRACTION



DREAM ARABESQUE



DCOF>
0,42 Wet
(matte)

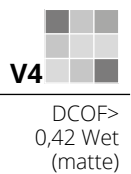

9 mm 3/8" ↑↓



6 mm 1/4" ↑↓

FLOHM OVERSIZE
magnUm

GRES PORCELLANATO COLORATO IN MASSA/COLOURED BODY PORCELAIN STONEWARE
GRÈS CÉRAME COLORE DANS LA MASSE/DURCHGEFÄRBTE FEINSTEINZEUG/GRES PORCELÁNICO COLOREADO EN MASA
SQUADRATO - SQUARED - EQUARRI - REKTIFIZIERT - ESCUADRADO

		9 mm 3/8" ↑↓		80x180 31 1/2" x 70 5/7"		80x80 31 1/2" x 31 1/2"		60x120 23 5/8" x 47 1/4"		60x60 23 5/8" x 23 5/8"		30x60 11 4/5" x 23 5/8"	
		COLOR	SURFACE										
PREXIOUS		PEARL ATTRACTION	GLOSSY	755819 ■ FL-11900	755831 ■ FL-10800	755847 ■ FL-11300	755871 ■ FL-09100	755884 ■ FL-07700					
			MATTE	755813 ■ FL-10500	755825 ■ FL-09300	755837 ■ FL-09900	755865 ■ FL-07300	755878 ■ FL-06200					
		DREAM ARABESQUE	GLOSSY	755818 ■ FL-11900	755830 ■ FL-10800	755846 ■ FL-11300	755870 ■ FL-09100	755883 ■ FL-07700					
			MATTE	755812 ■ FL-10500	755824 ■ FL-09300	755836 ■ FL-09900	755864 ■ FL-07300	755877 ■ FL-06200					

		6 mm 1/4" ↑↓		160x320 63" x 126"		120x280 47 1/4" x 110 1/4"		160x160 63" x 63"		120x240 47 1/4" x 94 1/4"		120x120 47 1/4" x 47 1/4"		80x80 31 1/2" x 31 1/2"		60x120 23 5/8" x 47 1/4"	
		COLOR	SURFACE														
PREXIOUS		DREAM ARABESQUE	GLOSSY	756427 ■ FL-18800	757738 ■ FL-15100	756439 ■ FL-16100	756287 ■ FL-14000	756391 ■ FL-12400	756415 ■ FL-10300	756403 ■ FL-11300							
			MATTE	756421 ■ FL-15600	757732 ■ FL-12400	756433 ■ FL-13400	756292 ■ FL-11300	756385 ■ FL-09700	756409 ■ FL-08400	756397 ■ FL-09100							

PREXIOUS

CHARMING AMBER



THUNDER NIGHT



DCOF >
0,42 Wet
(matte)

9 mm 3/8" ↑↓



DCOF >
0,42 Wet
(matte)

6 mm 1/4" ↑↓







FLOFORM OVERSIZE
magnum

GRES PORCELLANATO COLORATO IN MASSA/COLOURED BODY PORCELAIN STONEWARE
GRÈS CÉRAME COLORE DANS LA MASSE/DURCHGEFÄRBTE FEINSTEINZEUG/GRES PORCELÁNICO COLOREADO EN MASA
SQUADRATO - SQUARED - EQUARRI - REKTIFIZIERT - ESCUADRADO

				9 mm 3/8" ↑↓						
		COLOR	SURFACE	80x180 31 1/2"x70 6/7"	80x80 31 1/2"x31 1/2"	60x120 23 5/8"x47 1/4"	60x60 23 5/8"x23 5/8"	30x60 11 4/5"x23 5/8"		
PREXIOUS	CHARMING AMBER	GLOSSY		755817 ■ FL-11900	755829 ■ FL-10800	755845 ■ FL-11300	755869 ■ FL-09100	755882 ■ FL-07700		
		MATTE		755811 ■ FL-10500	755823 ■ FL-09300	755835 ■ FL-09900	755863 ■ FL-07300	755876 ■ FL-06200		
	THUNDER NIGHT	GLOSSY		755820 ■ FL-11900	755832 ■ FL-10800	755848 ■ FL-11300	755872 ■ FL-09100	755885 ■ FL-07700		
		MATTE		755814 ■ FL-10500	755826 ■ FL-09300	755838 ■ FL-09900	755866 ■ FL-07300	755879 ■ FL-06200		
				6 mm 1/4" ↑↓						
		COLOR	SURFACE	160x320 63"x126"	120x280 47 1/4"x110 1/4"	160x160 63"x63"	120x240 47 1/4"x94 1/2"	120x120 47 1/4"x47 1/4"	80x80 31 1/2"x31 1/2"	60x120 23 5/8"x47 1/4"
PREXIOUS	CHARMING AMBER	GLOSSY		756428 ■ FL-18800	757739 ■ FL-15100	756440 ■ FL-16100	755840 ■ FL-14000	756392 ■ FL-12400	756416 ■ FL-10300	756404 ■ FL-11300
		MATTE		756422 ■ FL-15600	757733 ■ FL-12400	756434 ■ FL-13400	756294 ■ FL-11300	756386 ■ FL-09700	756410 ■ FL-08400	756398 ■ FL-09100
	THUNDER NIGHT	GLOSSY		756429 ■ FL-18800	757740 ■ FL-15100	756441 ■ FL-16100	756286 ■ FL-14000	756393 ■ FL-12400	756417 ■ FL-10300	756405 ■ FL-11300
		MATTE		756423 ■ FL-15600	757734 ■ FL-12400	756435 ■ FL-13400	756291 ■ FL-11300	756387 ■ FL-09700	756411 ■ FL-08400	756399 ■ FL-09100

PEZZI SPECIALI/SPECIAL TRIMS/PIÈCES SPÉCIALES
FORMSTÜCKE/PIEZAS ESPECIALES

9 mm 3/8" ↑ ↓

COLOR	SURFACE	30x30 11 ^{4/5} "x11 ^{4/5} "	30x30 11 ^{4/5} "x11 ^{4/5} "
		mosaico tessere 3x15 pz/box 11	mosaico 3D Mix tessere 3x3 pz/box 9
 WHITE FANTASY	GLOSSY	756310 ▲ FL-02200	756316 ▲ FL-04900
	MATTE	756304 ▲ FL-02100	
 MOUNTAIN TREASURE	GLOSSY	756311 ▲ FL-02200	756317 ▲ FL-04900
	MATTE	756305 ▲ FL-02100	
 PEARL ATTRACTION	GLOSSY	756314 ▲ FL-02200	756320 ▲ FL-04900
	MATTE	756308 ▲ FL-02100	
 DREAM ARABESQUE	GLOSSY	756313 ▲ FL-02200	756319 ▲ FL-04900
	MATTE	756307 ▲ FL-02100	
 CHARMING AMBER	GLOSSY	756312 ▲ FL-02200	756318 ▲ FL-04900
	MATTE	756306 ▲ FL-02100	
 THUNDER NIGHT	GLOSSY	756315 ▲ FL-02200	756321 ▲ FL-04900
	MATTE	756309 ▲ FL-02100	

4,6x60 1 ^{4/5} "x23 ^{3/8} "	33x120x3 13"x47 ^{1/4} "x1 ^{1/8} "
battiscopa	gradino pz/box 2
756328 ◆ FL-01600	756340 ▲ FL-22600
756322 ◆ FL-01600	756334 ▲ FL-20400
756329 ◆ FL-01600	756341 ▲ FL-22600
756323 ◆ FL-01600	756335 ▲ FL-20400
756332 ◆ FL-01600	756344 ▲ FL-22600
756326 ◆ FL-01600	756338 ▲ FL-20400
756331 ◆ FL-01600	756343 ▲ FL-22600
756325 ◆ FL-01600	756337 ▲ FL-20400
756330 ◆ FL-01600	756342 ▲ FL-22600
756324 ◆ FL-01600	756336 ▲ FL-20400
756333 ◆ FL-01600	756345 ▲ FL-22600
756327 ◆ FL-01600	756339 ▲ FL-20400

PREXIOUS

9 mm 3/8" ↑ ↓

Product Certification
BUREAU VERITAS
Certification



Recycled material content certification

I formati 160x160 e 80x240 possono essere acquistati solo a multipli di 2 lastre. / Sales unit for 160x160 and 80x240 is 2 pcs, so they can only be bought in multiples of 2. / Les formats 160x160 et 80x240 sont vendus par multiples de 2 plaques / Die Formate 160x160 und 80x240 können nur in einer durch 2 teilbaren Anzahl bestellt werden / Las medidas 160x160 y 80x240 solo pueden comprarse en múltiplos de 2 placas







Per un effetto ottimale della posa, florim suggerisce di mantenere 2 mm di fuga per pose monoformato e 3 mm per combinare formati misti. - For optimal installation results, florim recommends maintaining a joint of 2 mm 1/12" for single format installations and 3 mm 1/8" to combine mixed formats. - Pour réaliser une pose parfaite, florim suggère de maintenir 2 mm de joint pour la pose des monoformats, et 3 mm pour les combinaisons de formats mixtes. - Um einen optimalen Effekt beim Verlegen zu erzielen empfiehlt florim eine 2 mm Fuge bei einformatigen Verlegungen und 3 mm Fuge bei Formatkombinationen. Para lograr los máximos resultados en la posa del producto, florim aconseja 2 mm de junta en aplicaciones monoformato y 3 mm en combinaciones de formatos mixtos

In relazione alle differenti tecnologie produttive l'accostamento di prodotti con spessori diversi potrebbe presentare delle disomogeneità, se ne sconsiglia pertanto l'abbinamento. / Due to the different production technologies, contiguous installation of products with different thickness may give a non-homogeneous result. For this reason we do not recommend this option. / Vu que différentes technologies de production sont utilisées avec des épaisseurs différentes, des problèmes d'homogénéité pourraient se présenter, il est donc déconseillé de les poser ensemble. / Wegen unterschiedlicher Produktionstechnologien können die Fliesen mit verschiedenen Materialstärken optische Differenzen aufweisen. Von einem direkten Aneinanderlegen wird deshalb abgeraten. / Dadas las diferentes tecnologías productivas, la combinación de productos de diferentes espesores podría dar lugar a heterogeneidad, por lo que se desaconseja mezclarlas.





PREXIOUS	scatola - box			pallet		
	pz	mq	kg	box	mq	kg
80x180	2	2,88	57,60	20	57,60	1210
80x80	2	1,28	24,96	40	51,20	1030
60x120	2	1,44	28,08	30	43,20	870
60x60	3	1,08	21,06	40	43,20	870
30x60	6	1,08	20,84	40	43,20	860

PREXIOUS	scatola - box			pallet		
	pz	ml	kg	box	mq	kg
4,6x60 battiscopa	14	8,40	8,40	-	-	-

PREXIOUS

6 mm 1/4" ↑↓				30x30 11 4/5" x 11 4/5"	30x30 11 4/5" x 11 4/5"
		COLOR	SURFACE	 mosaico tessere 7,5x7,5 pz/box 11	 muretto tessere 7,5x15 pz/box 11
PREXIOUS		WHITE FANTASY	GLOSSY	756364 ▲ FL-02100	756352 ▲ FL-02100
			MATTE	756358 ▲ FL-01800	756346 ▲ FL-01800
		DREAM ARABESQUE	GLOSSY	756367 ▲ FL-02100	756355 ▲ FL-02100
			MATTE	756361 ▲ FL-01800	756349 ▲ FL-01800
		CHARMING AMBER	GLOSSY	756366 ▲ FL-02100	756354 ▲ FL-02100
			MATTE	756360 ▲ FL-01800	756348 ▲ FL-01800
		THUNDER NIGHT	GLOSSY	756369 ▲ FL-02100	756357 ▲ FL-02100
			MATTE	756363 ▲ FL-01800	756351 ▲ FL-01800

PEZZI SPECIALI/SPECIAL TRIMS/PIÈCES SPÉCIALES/FORMSTÜCKE/PIEZAS ESPECIALES

6 mm 1/4" ↑↓				4,6x80 1 4/5" x 3 1/2"
		COLOR	SURFACE	 battiscopa
PREXIOUS		WHITE FANTASY	GLOSSY	756376 ◆ FL-01800
			MATTE	756370 ◆ FL-01800
		DREAM ARABESQUE	GLOSSY	756379 ◆ FL-01800
			MATTE	756373 ◆ FL-01800
		CHARMING AMBER	GLOSSY	756378 ◆ FL-01800
			MATTE	756372 ◆ FL-01800
		THUNDER NIGHT	GLOSSY	756381 ◆ FL-01800
			MATTE	756375 ◆ FL-01800

FLORM OVERSIZE
magnUm

160x320/120x280/160x160/120x240/120x120/60x120

Specifica Imballo pag.
Packaging specifications on page
Spécifications d'emballage à page
Verpackungsdetail Seite
Especificaciones de embalaje a la página

204/205





RÊVES

gres porcellanato colorato in massa
coloured body porcelain stoneware
grès cérame colore dans la masse
durchgefärbte feinsteinzeug
gres porcelánico coloreado en masa





RÊVES

Ispirata alla bellezza antica e ricercata degli alabastrini, la collezione **Rêves** ci restituisce un sogno di contemporanea eleganza attraverso sfumature preziose e raffinate cromie in linea con le attuali inclinazioni estetiche dell'abitare. Morbide venature e tenui contrasti di colore contrassegnano una collezione essenziale ed equilibrata che con uno stile autentico prende le distanze dalle tinte accese e appariscenti. Superfici luminose, profonde e delicate accompagnano le diverse architetture senza offuscarle ma riuscendo ad esaltarne spazio e dimensione.

Inspired by the ancient and exquisite beauty of alabaster, the **Rêves** collection evokes a dream of contemporary elegance through fine shades and refined colours in line with current living space aesthetics. Soft veins and subtle colour contrasts mark an essential and balanced collection whose authentic style distances itself from bright and flashy colours. Glossy, deep and delicate surfaces pair with various architectures, never overshadowing but rather enhancing their space and size.

S'inspirant de la beauté ancienne et raffinée des albâtres, la collection **Rêves** nous offre un rêve d'élégance contemporaine à travers des nuances précieuses et des couleurs raffinées, en accord avec les tendances esthétiques actuelles de l'habitat. Les douces veines et les délicats contrastes de couleurs caractérisent cette collection sobre et équilibrée qui, de par son style authentique, se démarque des couleurs vives et criardes. Des surfaces lumineuses, profondes et délicates accompagnent les différentes architectures sans les éclipser, bien au contraire, car elles réussissent à mettre en valeur leurs espaces et leurs dimensions.

Die Kollektion **Rêves** inspiriert sich an der antiken und erlesenen Schönheit von Alabaster und liefert einen Traum von kontemporärer Eleganz, mit kostbaren Nuancen und raffinierten Farben, die den aktuellen ästhetischen Wohntrends entsprechen. Weiche Äderungen und zarte Farbkontraste kennzeichnen eine wesentliche und ausgewogene Kollektion, die mit einem authentischen Stil von den kräftigen und auffälligen Farben Abstand nimmt. Helle, tiefe und zarte Oberflächen begleiten die verschiedenen Architekturen, ohne sie zu trüben, sondern sie betonen dagegen den Raum und die Größe.

Inspirada en la belleza antigua y sofisticada del alabastro, la colección **Rêves** presenta un sueño de elegancia contemporánea a través de matices preciosos y refinados colores acordes con las inclinaciones estéticas actuales para el hogar. Los suaves veteados y los contrastes tenues de color caracterizan una colección esencial y equilibrada que, con auténtico estilo, se distancia de los tonos más vivos y llamativos. Las superficies luminosas, profundas y delicadas acompañan a las distintas arquitecturas sin eclipsarlas, antes bien, resaltando su espacio y sus dimensiones.

RÊVES

RÊVE PERLE



RÊVE BLEU

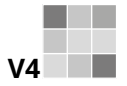

V4
DCOF >
0,42 Wet
(matte)

9 mm 3/8" ↑↓

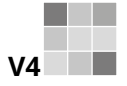





V4
DCOF >
0,42 Wet
(matte)

6 mm 1/4" ↑↓

FLOHM OVERSIZE
magnUm

GRES PORCELLANATO COLORATO IN MASSA/COLOURED BODY PORCELAIN STONEWARE
GRÈS CÉRAMÉ COLORE DANS LA MASSE/DURCHGEFÄRBTÉ FEINSTEINZEUG/GRES PORCELÁNICO COLOREADO EN MASA
SQUADRATO - SQUARED - EQUARRI - REKTIFIZIERT - ESCUADRADO

			9 mm 3/8" ↑↓					
		COLOR	SURFACE	80x180 31 1/2"x70 6/7"	60x120 23 5/8"x47 1/4"	60x60 23 5/8"x23 5/8"	30x60 11 4/5"x23 5/8"	
RÊVES		RÊVE PERLE	GLOSSY	770421 ■ FL-11900	769816 ■ FL-11300	769800 ■ FL-09100	769808 ■ FL-07700	
			MATTE	770417 ■ FL-10500	769812 ■ FL-09900	769795 ■ FL-07300	769804 ■ FL-06200	
		RÊVE BLEU	GLOSSY	770422 ■ FL-11900	769817 ■ FL-11300	769801 ■ FL-09100	769809 ■ FL-07700	
			MATTE	770418 ■ FL-10500	769813 ■ FL-09900	769796 ■ FL-07300	769805 ■ FL-06200	
			6 mm 1/4" ↑↓					
		COLOR	SURFACE	160x320 63"x126"	120x280 47 1/4"x110 1/4"	120x240 47 1/4"x94 1/2"	120x120 47 1/4"x47 1/4"	60x120 23 5/8"x47 1/4"
RÊVES		RÊVE PERLE	GLOSSY	769943 ■ FL-18800	769926 ■ FL-15100	769918 ■ FL-14000	769910 ■ FL-12400	769935 ■ FL-11300
			MATTE	769939 ■ FL-15600	769922 ■ FL-12400	769914 ■ FL-11300	769906 ■ FL-09700	769931 ■ FL-09100
		RÊVE BLEU	GLOSSY	769940 ■ FL-18800	769923 ■ FL-15100	769915 ■ FL-14000	769907 ■ FL-12400	769932 ■ FL-11300
			MATTE	769936 ■ FL-15600	769919 ■ FL-12400	769911 ■ FL-11300	769903 ■ FL-09700	769928 ■ FL-09100

RÊVE NOISETTE



RÊVE CHOCO



V4
DCOF>
0,42 Wet
(matte)

9 mm 3/8" ↑↓



V4
DCOF>
0,42 Wet
(matte)

6 mm 1/4" ↑↓

FLOHM OVERSIZE
magnum

GRES PORCELLANATO COLORATO IN MASSA/COLOURED BODY PORCELAIN STONEWARE
GRÈS CÉRAME COLORE DANS LA MASSE/DURCHGEFÄRBTE FEINSTEINZEUG/GRES PORCELÁNICO COLOREADO EN MASA
SQUADRATO - SQUARED - EQUARRI - REKTIFIZIERT - ESCUADRADO

			9 mm 3/8" ↑↓		6 mm 1/4" ↑↓		
		COLOR	SURFACE	80x180 31 1/2"x70 6/7"	60x120 23 5/8"x47 1/4"	60x60 23 5/8"x23 5/8"	30x60 11 4/5"x23 5/8"
RÊVES	RÊVE NOISETTE	GLOSSY	770423 ■ FL-11900	769818 ■ FL-11300	769802 ■ FL-09100	769810 ■ FL-07700	
		MATTE	770419 ■ FL-10500	769814 ■ FL-09900	769797 ■ FL-07300	769806 ■ FL-06200	
	RÊVE CHOCO	GLOSSY	770424 ■ FL-11900	769819 ■ FL-11300	769803 ■ FL-09100	769811 ■ FL-07700	
		MATTE	770420 ■ FL-10500	769815 ■ FL-09900	769798 ■ FL-07300	769807 ■ FL-06200	
RÊVES	RÊVE NOISETTE	GLOSSY	769942 ■ FL-18800	769925 ■ FL-15100	769917 ■ FL-14000	769909 ■ FL-12400	769934 ■ FL-11300
		MATTE	769938 ■ FL-15600	769921 ■ FL-12400	769913 ■ FL-11300	769905 ■ FL-09700	769930 ■ FL-09100
	RÊVE CHOCO	GLOSSY	769941 ■ FL-18800	769924 ■ FL-15100	769916 ■ FL-14000	769908 ■ FL-12400	769933 ■ FL-11300
		MATTE	769937 ■ FL-15600	769920 ■ FL-12400	769912 ■ FL-11300	769904 ■ FL-09700	769929 ■ FL-09100

RÊVES

RÊVE ROSE



RÊVE JADE

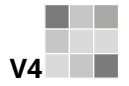

DCOF>
0,42 Wet
(matte)

9 mm 3/8" ↑↓

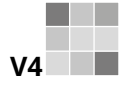

DCOF>
0,42 Wet
(matte)

6 mm 1/4" ↑↓

FLOHM OVERSIZE
magnUm











GRES PORCELLANATO COLORATO IN MASSA/COLOURED BODY PORCELAIN STONEWARE
GRÈS CÉRAME COLORE DANS LA MASSE/DURCHGEFÄRBTE FEINSTEINZEUG/GRES PORCELÁNICO COLOREADO EN MASA
SQUADRATO - SQUARED - EQUARRI - REKTIFIZIERT - ESCUADRADO

9 mm 3/8" ↑↓		COLOR	SURFACE	80x180 31 1/2"x70 6/7"	60x120 23 5/8"x47 1/4"						
RÊVES	RÊVE ROSE	GLOSSY		774995 ■ FL-11900	775000 ■ FL-11300						
		MATTE		774993 ■ FL-10500	774998 ■ FL-09900						
	RÊVE JADE	GLOSSY		774994 ■ FL-11900	774999 ■ FL-11300						
		MATTE		774992 ■ FL-10500	774996 ■ FL-09900						
6 mm 1/4" ↑↓		COLOR	SURFACE	160x320 63"x126"	120x280 47 1/4"x110 1/4"	120x240 47 1/4"x94 1/2"	120x120 47 1/4"x47 1/4"	60x120 23 5/8"x47 1/4"			
RÊVES	RÊVE ROSE	GLOSSY		774489 ■ FL-18800	774483 ■ FL-15100	774493 ■ FL-14000	774497 ■ FL-12400	774501 ■ FL-11300			
		MATTE		774488 ■ FL-15600	774482 ■ FL-12400	774492 ■ FL-11300	774496 ■ FL-09700	774500 ■ FL-09100			
	RÊVE JADE	GLOSSY		774487 ■ FL-18800	774481 ■ FL-15100	774491 ■ FL-14000	774495 ■ FL-12400	774499 ■ FL-11300			
		MATTE		774485 ■ FL-15600	774480 ■ FL-12400	774490 ■ FL-11300	774494 ■ FL-09700	774498 ■ FL-09100			



RÈVES

PEZZI SPECIALI/SPECIAL TRIMS/PIÈCES SPÉCIALES
FORMSTÜCKE/PIEZAS ESPECIALES

9 mm 3/8" ↑		COLOR	SURFACE	30x30 11 ^{4/5"} x11 ^{4/5"}  mosaico tessere 3x15 pz/box 11	30x30 11 ^{4/5"} x11 ^{4/5"}  mosaico mix tessere 3x3 pz/box 9	4,6x60 1 ^{4/5"} x23 ^{5/8"}  battiscopa	33x120x3 13 ^{3/4"} x47 ^{1/4"} x1 ^{1/8"}  gradino pz/box 2
	RÈVE PERLE	GLOSSY	770257 ▲ FL-02200	770249 ▲ FL-04900	770265 ◆ FL-01600	770273 ▲ FL-22600	
		MATTE	770253 ▲ FL-02100		770261 ◆ FL-01600	770269 ▲ FL-20400	
		RÈVE BLEU	GLOSSY	770254 ▲ FL-02200	770246 ▲ FL-04900	770262 ◆ FL-01600	770270 ▲ FL-22600
			MATTE	770250 ▲ FL-02100		770258 ◆ FL-01600	770266 ▲ FL-20400
		RÈVE NOISETTE	GLOSSY	770256 ▲ FL-02200	770248 ▲ FL-04900	770264 ◆ FL-01600	770272 ▲ FL-22600
			MATTE	770252 ▲ FL-02100		770260 ◆ FL-01600	770268 ▲ FL-20400
	RÈVE CHOCO	GLOSSY	770255 ▲ FL-02200	770247 ▲ FL-04900	770263 ◆ FL-01600	770271 ▲ FL-22600	
		MATTE	770251 ▲ FL-02100		770259 ◆ FL-01600	770267 ▲ FL-20400	
	RÈVE ROSE	GLOSSY	-	-	776193 ◆ FL-01600	-	
		MATTE	-	-	776194 ◆ FL-01600	-	
	RÈVE JADE	GLOSSY	-	-	776191 ◆ FL-01600	-	
		MATTE	-	-	776192 ◆ FL-01600	-	

RÈVES

9 mm 3/8" ↑

Product Certification
BUREAU VERITAS
Certification









Per un effetto ottimale della posa, florim suggerisce di mantenere 2 mm di fuga per pose monoformato e 3 mm per combinare formati misti. - For optimal installation results, florim recommends maintaining a joint of 2 mm - 1/12" for single format installations and 3 mm - 1/8" to combine mixed formats. - Pour réaliser une pose parfaite, florim suggère de maintenir 2 mm de joint pour la pose des monoformats, et 3 mm pour les combinaisons de formats mixtes. - Um einen optimalen effekt beim verlegen zu erzielen empfiehlt florim eine 2 mm fugе bei einformatigen verlegungen und 3 mm fugе bei formatkombinationen Para lograr los máximos resultados en la poša del producto, florim aconseja 2 mm de junta en aplicaciones monoformato y 3 mm en combinaciones de formatos mixtos







In relazione alle differenti tecnologie produttive l'accostamento di prodotti con spessori diversi potrebbe presentare delle disomogeneità, se ne sconsiglia pertanto l'abbinamento. / Due to the different production technologies, contiguous installation of products with different thickness may give a non-homogeneous result. For this reason we do not recommend this option. / Vu que différentes technologies de production sont utilisées avec des épaisseurs différentes, des problèmes d'homogénéité pourraient se présenter, il est donc déconseillé de les poser ensemble. / Wegen unterschiedlicher Produktionstechnologien können die Fliesen mit verschiedenen Materialstärken optische Differenzen aufweisen. Von einem direkten Aneinanderlegen wird deshalb abgeraten. / Dadas las diferentes tecnologías productivas, la combinación de productos de diferentes espesores podría dar lugar a heterogeneidad, por lo que se desaconseja mezclarlas.

RÈVES	scatola - box			pallet		
	pz	mq	kg	box	mq	kg
80x180	2	2,88	57,60	20	57,60	1210
60x120	2	1,44	28,08	30	43,20	870
60x60	3	1,08	21,06	40	43,20	870
30x60	6	1,08	20,84	40	43,20	860

RÈVES	scatola - box			pallet		
	pz	ml	kg	box	mq	kg
4,6x60 battiscopa	14	8,40	8,40	-	-	-

6 mm 1/4" ↑↓				30x30 11 4/5" x 11 4/5"  mosaico tessere 7,5x7,5 pz/box 11	30x30 11 4/5" x 11 4/5"  muretto tessere 7,5x15 pz/box 11
		COLOR	SURFACE		
RÊVES		RÊVE PERLE	GLOSSY	770289 ▲ FL-02100	770281 ▲ FL-02100
			MATTE	770285 ▲ FL-01800	770277 ▲ FL-01800
		RÊVE BLEU	GLOSSY	770286 ▲ FL-02100	770278 ▲ FL-02100
			MATTE	770282 ▲ FL-01800	770274 ▲ FL-01800
		RÊVE NOISETTE	GLOSSY	770288 ▲ FL-02100	770280 ▲ FL-02100
			MATTE	770284 ▲ FL-01800	770276 ▲ FL-01800
		RÊVE CHOCO	GLOSSY	770287 ▲ FL-02100	770279 ▲ FL-02100
			MATTE	770283 ▲ FL-01800	770275 ▲ FL-01800

PEZZI SPECIALI/SPECIAL TRIMS/PIÈCES SPÉCIALES/FORMSTÜCKE/PIEZAS ESPECIALES

6 mm 1/4" ↑↓				4,6x60 1 4/5" x 23 5/8"  battiscopa
		COLOR	SURFACE	
RÊVES		RÊVE PERLE	GLOSSY	770298 ◆ FL-01800
			MATTE	770294 ◆ FL-01800
		RÊVE BLEU	GLOSSY	770295 ◆ FL-01800
			MATTE	770291 ◆ FL-01800
		RÊVE NOISETTE	GLOSSY	770297 ◆ FL-01800
			MATTE	770293 ◆ FL-01800
		RÊVE CHOCO	GLOSSY	770296 ◆ FL-01800
			MATTE	770292 ◆ FL-01800
		RÊVE ROSE	GLOSSY	776197 ◆ FL-01800
			MATTE	776198 ◆ FL-01800
	RÊVE JADE	GLOSSY	776195 ◆ FL-01800	
		MATTE	776196 ◆ FL-01800	

FLORIM OVERSIZE
magnUm

160x320/120x280/120x240/120x120/60x120
 Specifica Imballo pag.
 Packaging specifications on page
 Spécifications d'emballage à page
 Verpackungsdetail Seite
 Especificaciones de embalaje a la página
204/205



SELECTION OAK

gres fine porcellanato
fine porcelain stoneware
grès cérame fin
feinsteinzeug-kollektionen
gres porcelánico fino





SELECTION OAK

L'essenza del rovere come ispirazione, una texture morbida e vellutata, 5 tonalità, selezionate con raffinata precisione, che ricordano le chiare atmosfere del mare e i caldi colori delle foreste incontaminate dove l'imperfezione della natura diventa perfetta armonia di toni e sfumature. Luxury design ha scelto un nuovo stile, una superficie che si richiama fortemente alla natura e porta con sé molteplici suggestioni, scelta per convivere con gli spazi e gli oggetti della memoria mescolati alle nuove proposte dell'architettura e dell'arredamento.

Taking its inspiration from oak wood, this has a soft, velvety texture and comes in 5 colours, selected with high-class precision to remind us of the light atmospheres of the sea and the warm colours of uncontaminated forests, where nature's imperfections turn into a perfect harmony of tones and shades. Luxury design has chosen a new style: the surface, strongly reminiscent of the natural world and bringing with it a wealth of delightful features, has been selected to blend into spaces and objects from past times mixed with new suggestions for architecture and furnishings.

L'essence de chêne comme source d'inspiration, avec une texture douce et veloutée. 5 tonalités sélectionnées avec précision et raffinement évoquent les atmosphères claires de la mer et les couleurs chaudes des forêts vierges, où l'imperfection de la nature compose une harmonie parfaite de tons et de nuances. Luxury design a choisi un nouveau style, une surface rappelant avec force la nature et portant en elle de multiples suggestions, pour accompagner les espaces et les objets de la mémoire associés aux nouvelles propositions de l'architecture et de la décoration.

Das Wesen der Eiche als Inspiration, eine weiche und samtige Beschaffenheit, 5 mit raffinierter Präzision ausgewählte Farbtöne, die an die klaren Stimmungen des Meers und die warmen Farben der unberührten Wälder erinnern, wo die Unvollkommenheit der Natur zur perfekten Harmonie von Tönen und Nuancen wird. Luxury design hat einen neuen Stil gewählt, eine Oberfläche, die sich stark an die Natur anlehnt und vielfältige Eindrücke hinterlässt, und die mit den Räumen und den Gegenständen der Erinnerung, vermischt mit dem neuen Angebot der Architektur und der Inneneinrichtung, auflebt.

La madera de roble como inspiración, una textura suave y aterciopelada, 5 tonalidades, seleccionadas con refinada precisión, que recuerdan las claras atmósferas del mar y los cálidos colores de las selvas incontaminadas, en las cuales la imperfección de la naturaleza se transforma en una perfecta armonía de tonos y matices. Luxury design ha elegido un nuevo estilo, una superficie que armoniza fuertemente con la naturaleza y consta de múltiples sugerencias, elegida para convivir con los espacios y los objetos de la memoria mezclados con nuevas propuestas arquitectónicas y decorativas.

SELECTION OAK

WHITE OAK



CREAM OAK



V3

R9
(matte)

R11
CLASSE C
(strutturato)



DCOF>
0,42 Wet

9 mm 3/8" ↑↓

GRES FINE PORCELLANATO

FINE PORCELAIN STONEWARE/GRES CERAME FIN/FEINSTEINZEUG-KOLLEKTIONEN/GRES PORCELANICO FINO

SQUADRATO - SQUARED - EQUARRI - REKTIFIZIERT - ESCUADRADO

9 mm 3/8" ↑↓	COLOR	SURFACE	26,5x180 10 ^{3/7"} x70 ^{6/7"}	20x180 7 ^{7/8"} x70 ^{6/7"}	20x120 7 ^{7/8"} x47 ^{1/4"}	15x120 6"x47 ^{1/4"}
SELECTION OAK	 WHITE OAK	MATTE	737647 ■ FL-12400	737653 ■ FL-12400	737659 ■ FL-09300	737665 ■ FL-09300
	 CREAM OAK	MATTE	737648 ■ FL-12400	737654 ■ FL-12400	737660 ■ FL-09300	737666 ■ FL-09300

AMBER OAK



BROWN OAK



V3

R9
(matte)

R11
CLASSE C
(strutturato)

DCOF>
0,42 Wet

9 mm 3/8" ↑↓

GRES FINE PORCELLANATO

FINE PORCELAIN STONEWARE/GRES CERAME FIN/FEINSTEINZEUG-KOLLEKTIONEN/GRES PORCELANICO FINO
SQUADRATO - SQUARED - EQUARRI - REKTIFIZIERT - ESCUADRADO

9 mm 3/8" ↑↓

	COLOR	SURFACE	26,5x180 10 ^{5/16"} x70 ^{5/16"}	20x180 7 ^{7/8"} x70 ^{5/16"}	20x120 7 ^{7/8"} x47 ^{1/4"}	15x120 6"x47 ^{1/4"}
SELECTION OAK	AMBER OAK	MATTE	737650 ■ FL-12400	737656 ■ FL-12400	737662 ■ FL-09300	737668 ■ FL-09300
	BROWN OAK	MATTE	737651 ■ FL-12400	737657 ■ FL-12400	737663 ■ FL-09300	737669 ■ FL-09300

SELECTION OAK

GRAY OAK



V3

R9
(matte)

R11
CLASSE C
(strutturato)

DCOF>
0,42 Wet

9 mm 3/8" ↑↓

GRES FINE PORCELLANATO
FINE PORCELAIN STONEWARE/GRES CERAME FIN/FEINSTEINZEUG-KOLLEKTIONEN/GRES PORCELANICO FINO
SQUADRATO - SQUARED - EQUARRI - REKTIFIZIERT - ESCUADRADO

9 mm 3/8" ↑↓	COLOR	SURFACE	26,5x180 10 ^{3/7"} x70 ^{6/7"}	20x180 7 ^{7/8"} x70 ^{6/7"}	20x120 7 ^{7/8"} x47 ^{1/4"}	15x120 6"x47 ^{1/4"}
SELECTION OAK	GRAY OAK	MATTE	737649 ■ FL-12400	737655 ■ FL-12400	737661 ■ FL-09300	737667 ■ FL-09300

9 mm 3/8" ↑↓				30x30 1 1/4" x 1 1/4"	15x45 6" x 1 7/8"
	COLOR	SURFACE	modulo listello tessere 7,5x30 pz/box 6	modulo listello sfalsato pz/box 6	
	WHITE OAK	MATTE	738021 ▲ FL-01160	738014 ▲ FL-02300	
	CREAM OAK	MATTE	738022 ▲ FL-01160	738015 ▲ FL-02300	
SELECTION OAK	AMBER OAK	MATTE	738024 ▲ FL-01160	738017 ▲ FL-02300	
	BROWN OAK	MATTE	738025 ▲ FL-01160	738018 ▲ FL-02300	
	GRAY OAK	MATTE	738023 ▲ FL-01160	738016 ▲ FL-02300	

PEZZI SPECIALI/SPECIAL TRIMS/PIÈCES SPÉCIALES/FORMSTÜCKE/PIEZAS ESPECIALES

9 mm 3/8" ↑↓				4,6x60 1 4/8" x 2 3/8"	40x120x3 15 3/4" x 47 1/4" x 1 1/8"	40x120x3 15 3/4" x 47 1/4" x 1 1/8"	40x120x3 15 3/4" x 47 1/4" x 1 1/8"	40x120x3 15 3/4" x 47 1/4" x 1 1/8"
	COLOR	SURFACE	battiscopa	gradino pz/box 2	angolo gradino DX pz/box 2	angolo gradino SX pz/box 2	angolo gradino DX/SX pz/box 1	
	WHITE OAK	MATTE	745461 ◆ FL-01600	738121 ▲ FL-21000	738127 ▲ FL-31100	738133 ▲ FL-31100	738139 ▲ FL-42900	
	CREAM OAK	MATTE	745459 ◆ FL-01600	738122 ▲ FL-21000	738128 ▲ FL-31100	738134 ▲ FL-31100	738140 ▲ FL-42900	
SELECTION OAK	AMBER OAK	MATTE	745456 ◆ FL-01600	738124 ▲ FL-21000	738130 ▲ FL-31100	738136 ▲ FL-31100	738142 ▲ FL-42900	
	BROWN OAK	MATTE	745458 ◆ FL-01600	738125 ▲ FL-21000	738131 ▲ FL-31100	738137 ▲ FL-31100	738143 ▲ FL-42900	
	GRAY OAK	MATTE	745460 ◆ FL-01600	738123 ▲ FL-21000	738129 ▲ FL-31100	738135 ▲ FL-31100	738141 ▲ FL-42900	

Product Certification

BUREAU VERITAS
Certification

Recycled material content certification



Nelle operazioni di posa a listoni sfalsati, si raccomanda sempre di fare in modo che il lato maggiore della piastrella termini a circa un terzo della lunghezza di quelle accanto (posa sfalsata "a 1/3"). - When installing staggered strips, we recommend that the tile's longer side should always end at about one-third of the length of the tiles next to it ("1/3" staggered installation) - Lors de la pose des listels décalés, il faut toujours faire en sorte que le côté le plus grand du carreau se trouve à environ 1/3 de la longueur des carreaux d'à côté (pose décalée "à 1/3"). - Beim Verlegen der Leisten in versetzter Form ist zu beachten, dass die höhere Seite der Fliese immer circa bei einem Drittel der Länge der sich daneben befindlichen Fliesen abschließt ("Um 1/3" versetzte Verlegung) - En las operaciones de colocación de listones escalonados, se recomienda hacerlo siempre de forma tal que el lado mayor del azulejo termine teniendo alrededor de un tercio de la longitud de los contiguos (colocación escalonada "a 1/3").

Per un effetto ottimale della posa, florim suggerisce di mantenere 2 mm di fuga per pose monoformato e 3 mm per combinare formati misti. - For optimal installation results, florim recommends maintaining a joint of 2 mm - 1/16" for single format installations and 3 mm - 1/8" to combine mixed formats. - Pour réaliser une pose parfaite, florim suggère de maintenir 2 mm de joint pour la pose des monoformats, et 3 mm pour les combinaisons de formats mixtes. - Um einen optimalen effekt beim verlegen zu erzielen empfiehlt florim eine 2 mm fugge bei einformatigen verlegungen und 3 mm fugge bei formatkombinationen Para lograr los máximos resultados en la posa del producto, florim aconseja 2 mm de junta en aplicaciones monoformato y 3 mm en combinaciones de formatos mixtos.

SELECTION OAK	scatola - box			pallet		
	pz	mq	kg	box	mq	kg
26,5x180	3	1,44	28,80	42	60,48	1270
20x180	4	1,44	33,12	40	57,60	1380
20x120	6	1,44	28,08	24	34,56	700
15x120	6	1,08	24,19	32	34,56	800

SELECTION OAK	scatola - box			pallet		
	pz	ml	kg	box	mq	kg
4,6x60 battiscopa	14	8,40	8,40	-	-	-

SELECTION OAK OUTDOOR

Vantaggi tecnici - Technical advantages - Avantages techniques Technische Vorteile - Ventajas técnicas

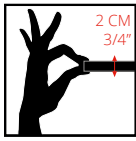

- Lastra monolitica compatta di spessore 2 cm squadrata e rettificata
- Compact monolithic slab 2 cm thick squared and rectified
- Dalle monolithique compacte de 2 cm d'épaisseur, équarrie et rectifiée
- Kompakte monolithische Platte, 2 cm dick, rechteckig und scharfkantig geschliffen
- Losa monolítica compacta de 2 cm de espesor, escuadrada y rectificada.

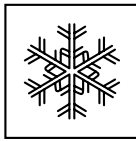

- INGELIVO
- FROST RESISTANT
- INGÉLIF
- FROSTBESTÄNDIG
- RESISTENTE A LA HELADA

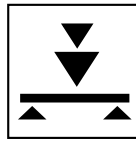

- ELEVATA RESISTENZA AI CARICHI STATICI
- HIGH STATIC LOAD RESISTANCE
- RÉSISTANCE ÉLEVÉE AUX CHARGES STATIQUES
- HOHE STATISCHE BELASTBARKEIT
- ELEVADA RESISTENCIA A LAS CARGAS ESTÁTICAS

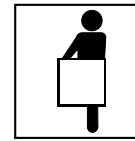

- FACILE DA POSARE
- EASY TO INSTALL
- FACILE À POSER
- VERLEGELEICHT
- FÁCIL DE COLOCAR



- ANTISCIVOLO R11
- ANTI SLIP R11
- ANTIDÉRAPANT R11
- RUTSCHFEST R11
- ANTIDESLIZANTE R11

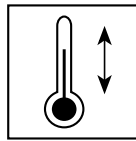

- RESISTENTE AGLI SBALZI TERMICI
- THERMAL SHOCK RESISTANT
- RÉSISTANT AUX ÉCARTS THERMIQUES
- TEMPERATURWECHSELBESTÄNDIG
- RESISTENTE A LAS OSCILACIONES TÉRMICAS



- FACILE DA PULIRE
- EASY TO CLEAN
- FACILE À NETTOYER
- REINIGUNGSLEICHT
- FÁCIL DE LIMPIAR

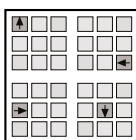

- RIMOVIBILE E RIUTILIZZABILE
- REMOVABLE AND REUSABLE
- DÉMONTABLE ET RÉUTILISABLE
- ENTFERNBAR UND WIEDERVERWENDBAR
- DESMONTABLE Y REUTILIZABLE



- INATTACCABILE DA AGENTI CHIMICI E MUFFE
- IMPERVIOUS TO ATTACK BY CHEMICALS OR MOULD
- RÉSISTANT AUX AGENTS CHIMIQUES ET AUX MOISSISSURES
- UNANGREIFBAR DURCH CHEMISCHE STOFFE UND SCHIMMEL
- RESISTENTE A LOS AGENTES QUÍMICOS Y A LOS MOHOS

Applicazioni - Applications - Applications - Verlegung - Aplicaciones

- Posa diretta su erba
- Direct installation on grass
- Pose direct sur de l'herbe
- Verlegung direkt auf Rasen
- Colocación directa sobre hierba

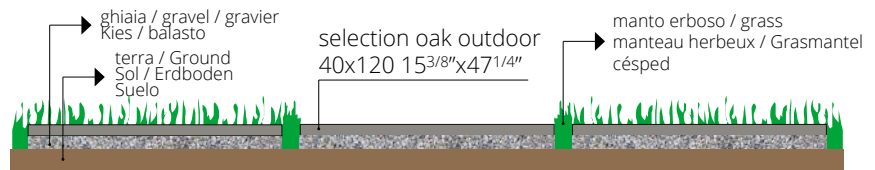

- Posa diretta su ghiaia
- Direct installation over gravel
- Pose direct sur du gravier
- Verlegung direkt auf Kies
- Colocación directa sobre grava



- Posa su massetto cementizio
- Installation on sand-cement screed
- Pose sur chape ciment
- Verlegung auf Zement-Unterbetonblock
- Colocación sobre contrapiso de hormigón

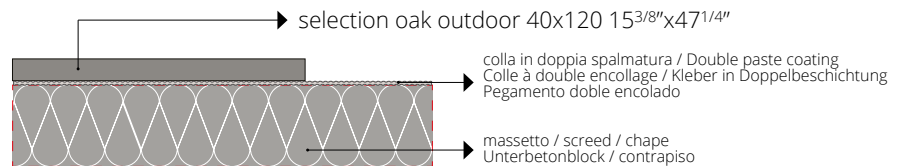

- Posa su piedini fissi o regolabili
- Installation on fixed or adjustable feet
- Pose sur pieds fixes ou réglables
- Verlegung auf feststehende oder regulierbare Füße
- Colocación sobre pies fijos o regulables

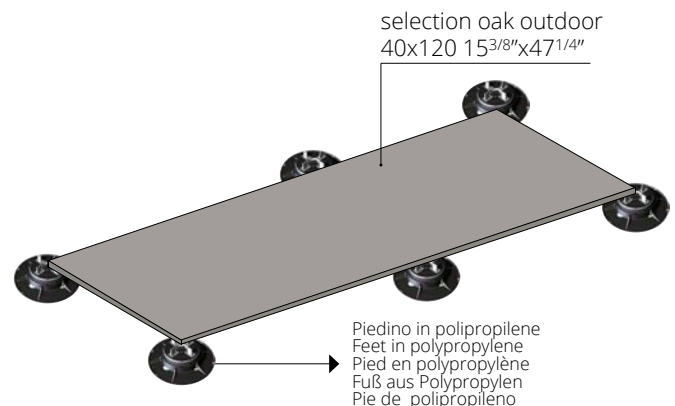

Per le specifiche di utilizzo dei sistemi sopraelevati vedi il sito florim.com
For the specifics on use of raised systems visit the site florim.com
Pour les caractéristiques d'utilisation des systèmes surélevés, voir le site florim.com
Für die Nutzungsbedingungen der Doppelbodensysteme siehe Webseite florim.com
Para las especificaciones de empleo de los sistemas sobreelevados consulte el sitio web florim.com

Le lastre ceramiche sono sottoposte a un trattamento di compattazione termica che assicura resistenza e durata nel tempo. Il bassissimo assorbimento d'acqua rende perciò il materiale ingelivo. Ciò può comportare ristagni d'acqua superficiali anche per materiale installato a regola d'arte. / Ceramic tiles undergo a compacting thermal treatment that ensures resistance and durability. The low level of water absorption makes the slabs frost resistant. This could result in superficial water stagnations even if materials are installed in a workmanlike manner. / Les carreaux de céramique subissent un traitement thermique de compactage qui assure résistance et durabilité. Le bas niveau d'absorption d'eau rend les dalles résistant au gel. Il pourrait en résulter des stagnations d'eau superficielles, même si les dalles ont été installées dans les règles de l'art. / Die Keramikplatten werden einer thermischen Verdichtung unterzogen, welche die Widerstandsfähigkeit und Langlebigkeit sichert. Die extrem niedrige Wasseraufnahme macht das Material frostsicher. Die hohe Materialdichte kann, auch bei einer perfekten Verlegung, eine längere Abtrochnungszeit von angestaumtem Wasser zur Folge haben. / Las baldosas cerámicas se someten a un tratamiento de compactación térmica que asegura resistencia y durabilidad. La baja absorción de agua hace que las baldosas resistan al hielo. Esto podría resultar en estancamientos superficiales de agua, incluso si los materiales están instalados según las reglas del arte.

AMBER OAK

GRAY OAK



V3 



R11
(strutturato)

CLASSE
A+B

20 mm 3/4" 

GRES FINE PORCELLANATO

FINE PORCELAIN STONEWARE/GRES CERAME FIN/FEINSTEINZEUG-KOLLEKTIONEN/GRES PORCELANICO FINO
SQUADRATO - SQUARED - EQUARRI - REKTIFIZIERT - ESCUADRADO

20 mm 3/4" 	COLOR	SURFACE	40x120 15 ^{3/4} "x47 ^{1/4} "
SELECTION OAK	 AMBER OAK	STRUTTURATO	744635 ■ FL-10800
	 GRAY OAK	STRUTTURATO	744636 ■ FL-10800

	RESISTENZA ALLA FLESSIONE IN N/mm ² N/mm ² FLEXURAL STRENGTH TEST / RESISTANCE A LA FLEXION EN N/mm ² / BIEGESTIGKEIT IN N/mm ² / RESISTENCIA A LA FLEXION EN N/mm ²	valore medio 52 N/mm²
	Forza di rottura in N (sp. > 7,5 mm) Breaking strength in N (thickness > 7,5 mm) / Force de rupture en N (ép. > 7,5 mm) / Bruchlast in N (Dicke > 7,5 mm) / Fuerza de rotura en N (gr. > 7,5 mm)	valore medio 14000 N

Product Certification
BUREAU VERITAS
Certification



Recycled material content certification

PEZZI SPECIALI

Special trims/Pièces spéciales/Formstücke
Piezas especiales/СПЕЦИАЛЬНЫЕ ИЗДЕЛИЯ
pag 194/197

SELECTION OAK	scatola - box			pallet		
	pz	mq	kg	box	mq	kg
40x120 20mm	2	0,96	43,10	24	23,04	1060

OUTDOOR 20mm PEZZI SPECIALI

SPECIAL TRIMS
PIÈCES SPÉCIALES
FORMSTÜCKE
PIEZAS ESPECIALES



CARATTERISTICHE TECNICHE



TECHNICAL FEATURES
CARACTÉRISTIQUES TECHNIQUES
TECHNISCHE EIGENSCHAFTEN
CARACTERÍSTICAS TÉCNICAS

Pezzi speciali Outdoor 20mm

Special trims/Pièces spéciales/Formstücke / Piezas especiales

Collections:

La roche - Matières - Atmosphères

Gradino toro

30x60 11^{4/5"}x23^{5/8"}_759176 ▲ FL-06400

40x120 15^{3/4"}x47^{1/4"}_759179 ▲ FL-20400

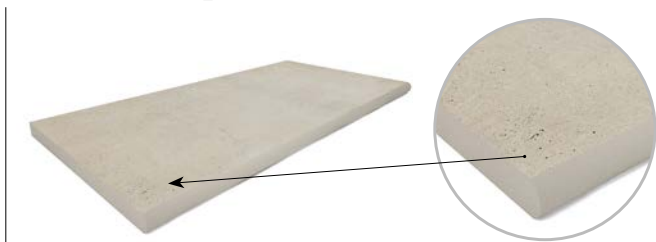

Collections:

Selection oak

Gradino toro

40x120 15^{3/4"}x47^{1/4"}_759179 ▲ FL-20400

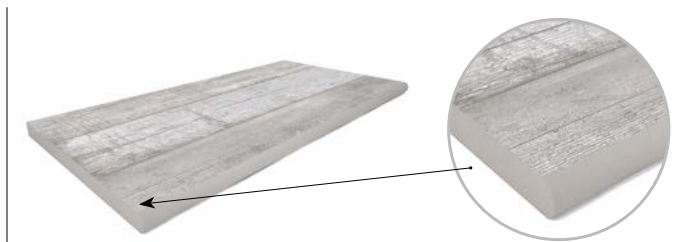

Gradino toro con gocciolatoio

30x60 11^{4/5"}x23^{5/8"}_759181 ▲ FL-09100

40x120 15^{3/4"}x47^{1/4"}_759184 ▲ FL-29000

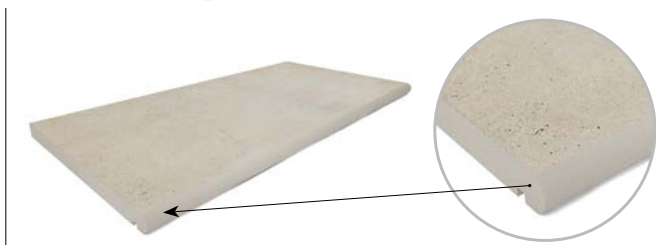

Gradino toro con gocciolatoio

40x120 15^{3/4"}x47^{1/4"}_759184 ▲ FL-29000

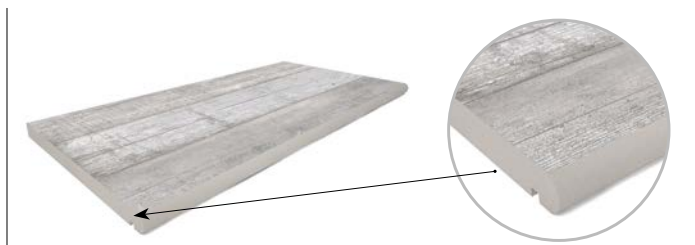

Gradino doppio toro

30x60 11^{4/5"}x23^{5/8"}_759186 ▲ FL-11300

40x120 15^{3/4"}x47^{1/4"}_759188 ▲ FL-36500

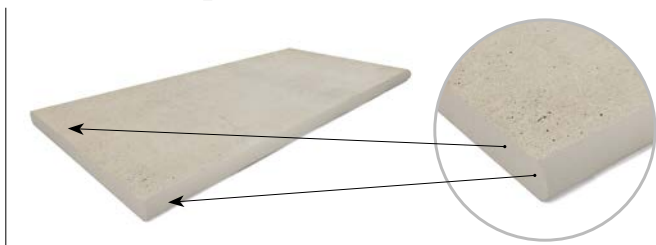

Gradino doppio toro

40x120 15^{3/4"}x47^{1/4"}_759188 ▲ FL-36500

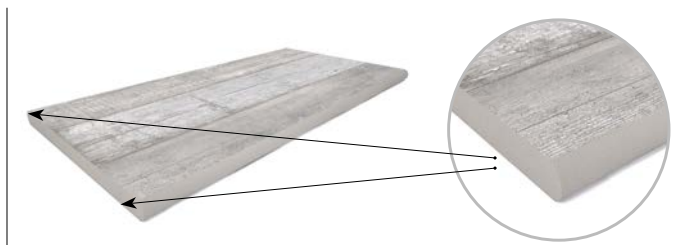

Gradino doppio toro con gocciolatoio

30x60 11^{4/5"}x23^{5/8"}_759190 ▲ FL-15600

40x120 15^{3/4"}x47^{1/4"}_759192 ▲ FL-29000

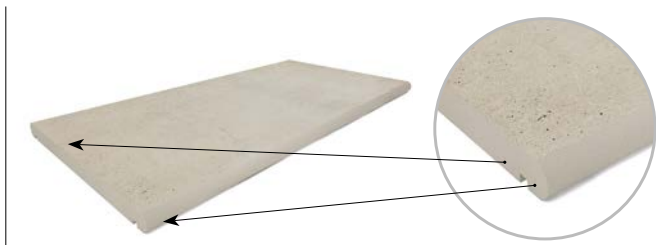

Gradino doppio toro con gocciolatoio

40x120 15^{3/4"}x47^{1/4"}_759192 ▲ FL-29000

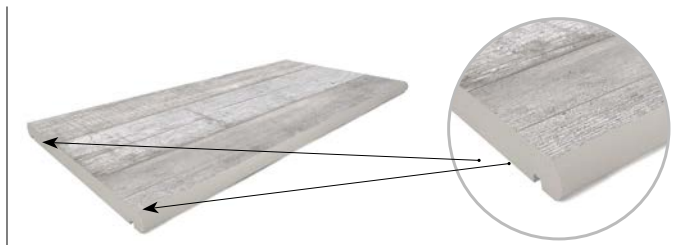

PEZZI SPECIALI OUTDOOR 20mm	scatola - box			pallet		
	pz	mq	kg	box	mq	kg
30x60 gradino toro	1	0,18	10,00	-	-	-
40x120 gradino toro	1	0,48	25,00	-	-	-
30x60 gradino toro con gocciolatoio	1	0,18	10,00	-	-	-
40x120 gradino toro con gocciolatoio	1	0,48	25,00	-	-	-
30x60 gradino doppio toro	1	0,18	10,00	-	-	-
40x120 gradino doppio toro	1	0,48	25,00	-	-	-
30x60 gradino doppio toro con gocciolatoio	1	0,18	10,00	-	-	-
40x120 gradino doppio toro con gocciolatoio	1	0,48	25,00	-	-	-

Collections:

La roche - Matières - Atmosphères

Elemento ad Elle Angolo SX

30x60x8 11^{4/5"}x23^{5/8"}x3^{1/8"}_759203 ▲ FL-14500

40x120x8 15^{3/4"}x47^{1/4"}x3^{1/8"}_759214 ▲ FL-29000

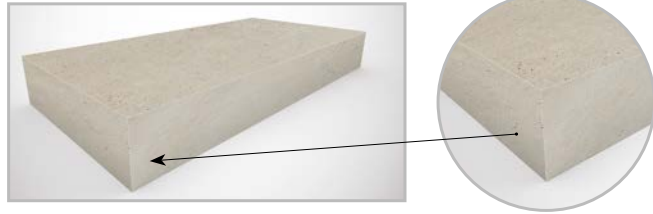

Elemento ad Elle Angolo SX

60x60x8 23^{5/8"}x23^{5/8"}x3^{1/8"}_759209 ▲ FL-19900

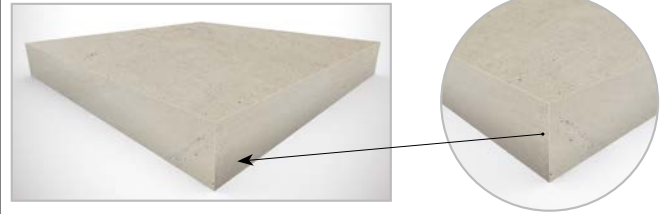

Elemento ad Elle

30x60x8 11^{4/5"}x23^{5/8"}x3^{1/8"}_759196 ▲ FL-09300

40x120x8 15^{3/4"}x47^{1/4"}x3^{1/8"}_759211 ▲ FL-19900

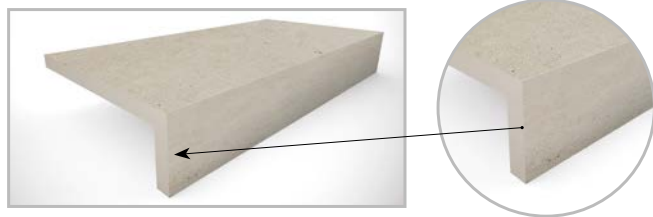

Elemento ad Elle

60x60x8 23^{5/8"}x23^{5/8"}x3^{1/8"}_759205 ▲ FL-14000

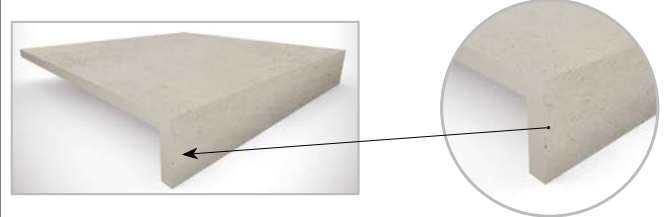

Elemento ad Elle Angolo DX

30x60x8 11^{4/5"}x23^{5/8"}x3^{1/8"}_759201 ▲ FL-14500

40x120x8 15^{3/4"}x47^{1/4"}x3^{1/8"}_759212 ▲ FL-29000

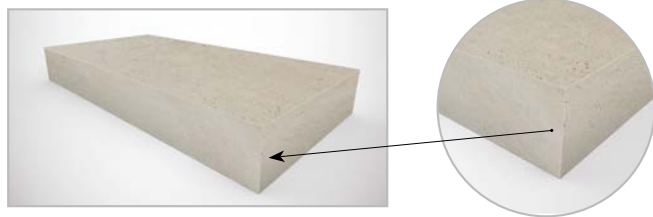

Elemento ad Elle Angolo DX

60x60x8 23^{5/8"}x23^{5/8"}x3^{1/8"}_759207 ▲ FL-19900

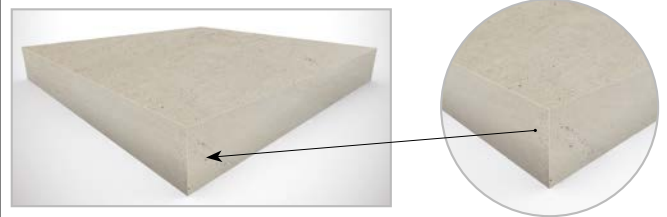

Pezzi speciali e fondo possono differire in termini di tonalità, il bordo può presentare stratificazioni di tonalità diverse.

Special pieces and field tiles may come in different shades, the slab's edge may show layers of differing hues.
 Il peut y avoir des différences de tonalités entre les pièces spéciales et le fond, le bord pourrait présenter des stratifications de tonalités différentes.
 Die Formteile können farblich von der Grundplatte abweichen, ihre Kanten können Schichtungen in unterschiedlichen Farbtönen aufweisen.
 Piezas especiales y bases pueden diferir en términos de tonalidad, el borde puede presentar estratificaciones de diferente tonalidad.

PEZZI SPECIALI OUTDOOR 20mm	scatola - box			pallet		
	pz	mq	kg	box	mq	kg
30x60x8 elemento ad elle angolo sx	1	0,18	10,00	-	-	-
40x120x8 elemento ad elle angolo sx	1	0,48	25,00	-	-	-
30x60x8 elemento ad elle	1	0,18	10,00	-	-	-
40x120x8 elemento ad elle	1	0,48	25,00	-	-	-
30x60x8 elemento ad elle angolo dx	1	0,18	10,00	-	-	-
40x120x8 elemento ad elle angolo dx	1	0,48	25,00	-	-	-
60x60x8 elemento ad elle angolo sx	1	0,36	20,00	-	-	-
60x60x8 elemento ad elle	1	0,36	20,00	-	-	-
60x60x8 elemento ad elle angolo dx	1	0,36	20,00	-	-	-

Pezzi speciali Outdoor 20mm

Special trims/Pièces spèciales/Formstüke / Piezas especiales

Collections:
Selection oak

Elemento ad Elle Angolo A SX

40x120x8 15^{3/4"}x47^{1/4"}x3^{1/8"}_753673 ▲ FL-29000

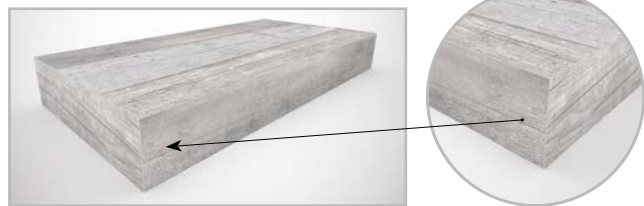

Elemento ad Elle A

40x120x8 15^{3/4"}x47^{1/4"}x3^{1/8"}_753670 ▲ FL-19900

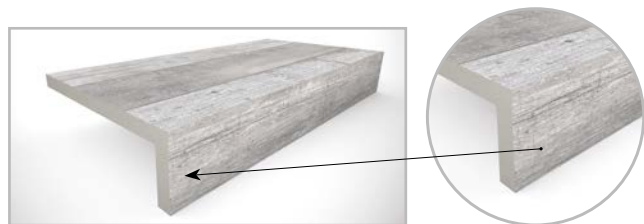

Elemento ad Elle Angolo A DX

40x120x8 15^{3/4"}x47^{1/4"}x3^{1/8"}_753672 ▲ FL-29000



Elemento ad Elle Angolo B SX

40x120x8 15^{3/4"}x47^{1/4"}x3^{1/8"}_753849 ▲ FL-29000



Elemento ad Elle B

40x120x8 15^{3/4"}x47^{1/4"}x3^{1/8"}_753671 ▲ FL-19900

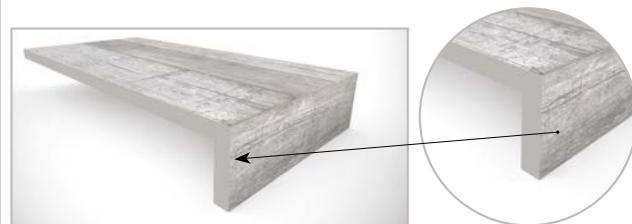

Elemento ad Elle Angolo B DX

40x120x8 15^{3/4"}x47^{1/4"}x3^{1/8"}_753848 ▲ FL-29000

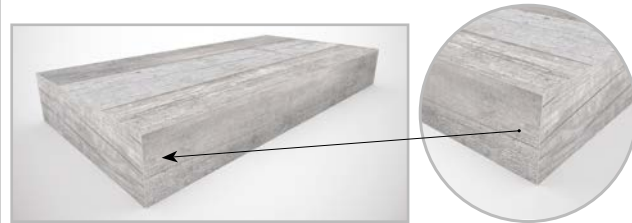

PEZZI SPECIALI OUTDOOR 20mm	scatola - box			pallet		
	pz	mq	kg	box	mq	kg
40x120x8 elemento ad elle angolo A sx	1	0,48	25,00	-	-	-
40x120 elemento ad elle A	1	0,48	25,00	-	-	-
40x120x8 elemento ad elle angolo A dx	1	0,48	25,00	-	-	-
40x120x8 elemento ad elle angolo B sx	1	0,48	25,00	-	-	-
40x120 elemento ad elle B	1	0,48	25,00	-	-	-
40x120x8 elemento ad elle angolo B dx	1	0,48	25,00	-	-	-

Collections: Selection oak



esempio di posa elemento A + angolo A SX
40x120x8 15^{3/4}”x47^{1/4}”



esempio di posa elemento B + angolo B SX
40x120x8 15^{3/4}”x47^{1/4}”

Pezzi speciali e fondo possono differire in termini di tonalità, il bordo può presentare stratificazioni di tonalità diverse.

Special pieces and field tiles may come in different shades, the slab's edge may show layers of differing hues.
Il peut y avoir des différences de tonalités entre les pièces spéciales et le fond, le bord pourrait présenter des stratifications de tonalités différentes.
Die Formteile können farblich von der Grundplatte abweichen, ihre Kanten können Schichtungen in unterschiedlichen Farbtönen aufweisen.
Piezas especiales y bases pueden diferir en términos de tonalidad, el borde puede presentar estratificaciones de diferente tonalidad.

BORDO VASCA

SWIMMING POOL EDGE
BORD DE PISCINE
BECKENRAND
BORDE DE LA TINA



CARATTERISTICHE TECNICHE



TECHNICAL FEATURES
CARACTÉRISTIQUES TECHNIQUES
TECHNISCHE EIGENSCHAFTEN
CARACTERÍSTICAS TÉCNICAS

WAVE/SPECIALPIECES

BORDO VASCA / SWIMMING POOL EDGE / BORD DE PISCINE
BECKENRAND / BORDE DE LA TINA

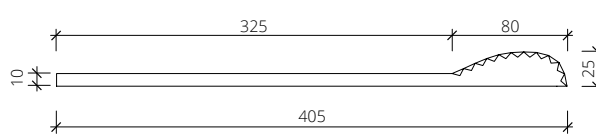
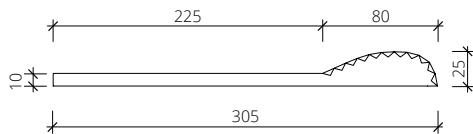

BORDO PER PISCINA "WAVE"

Rivoluzionario pezzo speciale che, attraverso l'accostamento di una serie di listelli opportunamente conformati su un lato del pezzo, rende ottimale la tracimazione, il contenimento dell'acqua, nonché l'appiglio manuale. La flessibilità progettuale di questo pezzo consente di realizzare bordi con diversi materiali Florim selezionati tra le serie che presentano le più elevate proprietà antiscivolo a piedi nudi (classe A+B+C, rif. norma DIN 51097).

"WAVE" SWIMMING POOL EDGE

Revolutionary border tile that, by placing together a set of suitably shaped strips on one side of the tile, makes an efficient overflow, containing the water and also offering a hand-grip. The flexibility of the design of this tile enables edges to be created with different Florim materials selected from the ranges that have the highest barefoot slip-resistance ratings (Class A+B+C, according to DIN 51097 standard).

BORD POUR PISCINE « WAVE »

Pièce spéciale révolutionnaire qui, grâce à la juxtaposition d'une série de listels dûment disposés sur un côté de la pièce, optimise le débordement, le confinement de l'eau, ainsi que le point d'accroche avec les mains. La flexibilité de conception de cette pièce permet de réaliser des bords avec différents matériaux Florim sélectionnés parmi les séries dotées des plus hautes propriétés antidérapantes pieds nus (classe A+B+C, réf. norme DIN 51097).

BECKENRANDSTEIN "WAVE"

Ein revolutionäres Spezialteil, das durch das Aneinandersetzen einer Reihe von Leisten, die an einer Seite des Spezialteils zweckmäßig geformt sind, eine ausgezeichnete Überflutung, Wassereindämmung und Griffkante bietet. Die flexible Projektanpassung dieses Spezialteils erlaubt die Gestaltung von Beckenrändern mit verschiedenen Florim-Materialien, ausgewählt unter den Produktserien mit der höchsten Barfuß-Rutschfestigkeit (Klasse A+B+C, Bezugsnorm DIN 51097).

BORDE PARA PISCINA «WAVE»

Pieza especial revolucionaria que se remata por un lado con una serie de listones de forma especial, para ofrecer un desbordamiento y retención del agua óptimos, así como un excelente asidero manual. La flexibilidad de diseño de esta pieza permite realizar bordes con varios materiales de Florim, seleccionados entre las series que presentan las más altas propiedades antideslizantes con pies descalzos (clase A+B+C, ref. norma DIN 51097).

OCEAN/SPECIALPIECES

BORDO VASCA / SWIMMING POOL EDGE / BORD DE PISCINE
BECKENRAND / BORDE DE LA TINA

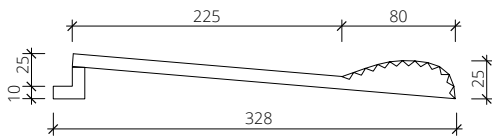

BORDO PER PISCINA "OCEAN"

Innovativo e rivoluzionario pezzo speciale progettato appositamente per essere utilizzato come bordo piscina con sistema ad acqua traboccante a sfioro. E' composto da un pezzo che, attraverso l'accostamento di una serie di listelli opportunamente conformati su un lato del pezzo, rende ottimale la trascinazione, il contenimento dell'acqua, nonché l'appiglio manuale. La flessibilità progettuale di questo pezzo consente di realizzare bordi con diversi materiali Florim selezionati tra le serie che presentano le più elevate proprietà antiscivolo a piedi nudi (classe A+B+C, rif. norma DIN 51097). Questo pezzo speciale comprende anche l'angolare in porcellanato per appoggio e contenimento griglia.

"OCEAN" SWIMMING POOL EDGE

Innovative, revolutionary border tile specially designed to be used as a swimming pool edge with overflow system. It comprises a piece that, by placing together a set of suitably shaped strips on one side of the tile, makes an efficient overflow, containing the water and also offering a hand-grip. The flexibility of the design of this tile enables edges with different Florim materials to be created, selecting them from the ranges that have the highest barefoot slip-resistance ratings (Class A+B+C, according to DIN 51097 standard). This special piece also includes the porcelain stoneware corner element for setting and containing the grating.

BORD POUR PISCINE « OCEAN »

Pièce spéciale innovante et révolutionnaire spécialement conçue pour être utilisée comme bord de piscine à débordement avec système de trop-plein. Grâce à la juxtaposition d'une série de listels dûment disposés sur un de ses côtés, cette pièce, optimise le débordement, le confinement de l'eau, ainsi que le point d'accroche avec les mains. La flexibilité de conception de cette pièce permet de réaliser des bords avec différents matériaux Florim sélectionnés parmi les séries dotées des plus hautes propriétés antidérapantes pieds nus (classe A+B+C, réf. norme DIN 51097). Cette pièce spéciale comprend également une pièce d'angle en grès cérame pour le support et le confinement de la grille.

BECKENRANDSTEIN "OCEAN"

Dieses innovative und revolutionäre Spezialteil wurde speziell für die Verwendung als Rand für Schwimmbecken mit Wasserüberlauftrinne entwickelt. Es besteht aus einem Teil, das durch das Aneinandersetzen einer Reihe von Leisten, die an einer Seite des Teils zweckmäßig geformt sind, eine ausgezeichnete Überflutung, Wassereindämmung und Griffkante bietet. Die flexible Projektanpassung dieses Spezialteils erlaubt die Gestaltung von Beckenrändern mit verschiedenen Florim-Materialien, ausgewählt unter den Produktserien mit der höchsten Barfuß-Rutschfestigkeit (Klasse A+B+C, Bezugsnorm DIN 51097). Dieses Spezialteil enthält auch das Eckstück aus Feinsteinzeug zur Aufnahme des Rostes.

BORDE PARA PISCINA «OCEAN»

Pieza especial, innovadora y revolucionaria, diseñada específicamente para usarse como borde de piscina con sistema de agua desbordante. Consta de una pieza que se remata por un lado con una serie de listones de forma especial, para ofrecer un desbordamiento y retención del agua óptimos, así como un excelente asidero manual. La flexibilidad de diseño de esta pieza permite realizar bordes con varios materiales de Florim, seleccionados entre las series que presentan las más altas propiedades antideslizantes con pies descalzos (clase A+B+C, ref. norma DIN 51097). Esta pieza especial también incluye la pieza angular de porcelánico de apoyo y sujeción de la rejilla.

CARATTERISTICHE - VANTAGGI TECNICI

1. Modularità a base 60/80 cm (in base alla collezione scelta).
2. Facilità di posa, con collanti di normale uso per la ceramica.
3. Elevata leggerezza.
4. Alta resistenza meccanica ai carichi.
5. Sicurezza allo scivolamento.
6. Costanza e precisione dimensionale.
7. Ergonomia che facilita l'appiglio manuale.
8. Conformazione che ottimizza la tracimazione e il contenimento dell'acqua.
9. Massima igiene.
10. Totale impermeabilità.
11. Possibilità di realizzazione con diverse collezioni antiscivolo Florim.
12. Ridotta incidenza nel costo complessivo della vasca.
13. Il taglio dei pezzi in cantiere, deve essere fatto con sistemi adeguati (es. taglio ad acqua con disco diamantato).

TAGLI

E' possibile fornire pezzi tagliati a misura di varie forme e dimensioni. Prezzi e condizioni di vendita sono da stabilire, con specifica offerta da parte della divisione "FLORIM SOLUTIONS".

CARACTÉRISTIQUES - AVANTAGES TECHNIQUES

1. Modularité à la base 60/ 80 cm (en fonction de la collection choisie)
2. Facilité de pose, avec des adhésifs à usage normal pour la céramique.
3. Légèreté élevée.
4. Haute résistance mécanique aux charges.
5. Antidérapant.
6. Constance et précision dimensionnelles.
7. Ergonomie qui facilite la prise manuelle.
8. Conformation qui optimise le débordement et le confinement de l'eau.
9. Hygiène maximale.
10. Étanchéité totale.
11. Possibilité de mise en œuvre avec diverses collections Anti dérapant Florim.
12. Incidence réduite dans le coût global de la piscine.
13. La découpe des pièces sur le chantier doit être effectuée avec des systèmes adéquats (par ex. découpe à eau avec disque diamanté).

PIÈCES COUPÉES

Il est possible de fournir des pièces coupées sur mesure de diverses formes et dimensions. Prix et conditions de vente à établir avec une offre spécifique de la part de la division «FLORIM SOLUTIONS».

CARACTERÍSTICAS - VENTAJAS TÉCNICAS

1. Modularidad en base a 60/ 80 cm (según la colección elegida)
2. Facilidad de colocación, con encolados de uso normal para cerámicos.
3. Elevada ligereza.
4. Alta resistencia mecánica a las cargas.
5. Seguridad contra el deslizamiento.
6. Constancia y precisión dimensional.
7. Ergonomía que facilita el agarre manual.
8. Configuración que optimiza el desbordamiento y la contención del agua.
9. Máxima higiene.
10. Total impermeabilidad.
11. Posibilidad de realización con las distintas colecciones de antideslizantes Florim.
12. Reducida incidencia en el coste total de la tina.
13. El corte de las piezas en las obras se debe realizar con sistemas adecuados (por ejemplo: corte de agua con disco diamantado).

CORTES

Es posible proveer piezas cortadas a la medida de varias formas y dimensiones. Los precios y condiciones de venta se deben fijar mediante una oferta específica de la división "FLORIM SOLUTIONS".

TECHNICAL CHARACTERISTICS - ADVANTAGES

1. Modularity with 60/ 80 CM (based on the chosen collection)
2. Easy to lay with adhesives normally used for ceramic materials.
3. Ultra-light weight.
4. High mechanical load resistance.
5. Non-slip safety.
6. Dimensional constancy and precision.
7. Ergonomics that facilitate manual gripping.
8. Conformation that optimises the overflow and containment of water.
9. Maximum hygiene.
10. Total impermeability.
11. Possibility to create using different Florim antislip collections.
12. Reduced incidence on the total cost of the pool.
13. The cutting of the pieces on the work site must be done using suitable systems (e.g. water cut with diamond disk).

CUTS

It is possible to supply pieces cut to measure in various shapes and sizes. Prices and sales conditions are to be stipulated with a specific offer by the FLORIM SOLUTIONS Division.

MERKMALE - TECHNISCHE VORZÜGE

1. Modularität auf der Basis von 60/80 cm (basierend auf der ausgesuchten Kollektion)
2. Einfache Verlegung mit den üblichen Klebern für Keramik.
3. Äußerste Leichtigkeit.
4. Hohe mechanische Belastungsfestigkeit.
5. Rutschfestigkeit.
6. Maßbeständigkeit und -genauigkeit.
7. Ergonomische Form, die das Greifen mit der Hand erleichtert.
8. Beschaffenheit, die den Überlauf und die Eindämmung des Wassers optimiert.
9. Maximale Hygiene.
10. Vollkommene Wasserundurchlässigkeit.
11. Möglichkeit der Herstellung mit verschiedenen rutschfest Serien von Florim.
12. Geringe Auswirkung auf die Gesamtkosten des Beckens.
13. Das Schneiden der Teile an der Baustelle hat mit geeigneten Systemen (z.B. Wasserstrahlschneiden mit Diamantscheibe) zu erfolgen.

ZUSCHNITT

Es können nach Maß zugeschnittene Teile in verschiedenen Formen und Größen geliefert werden. Preise und Verkaufsbedingungen sind in speziellem Angebot der Abteilung "FLORIM SOLUTIONS" festzulegen.

WAVE/OCEAN/PACKAGES

WAVE LINEARE	40,5x80
WAVE ANGOLO AE	40,5x40,5
WAVE ANGOLO AI 45°	40,5x80x80
OCEAN LINEARE	32x80
OCEAN ANGOLO AE	30,5x30,5
OCEAN ANGOLO AI 45°	32x80x80

BOXES



PZ

MQ

KG

PALLETS



PZ

MQ

KG

2	-	8,60	-	-	-
2	-	4,90	-	-	-
1	-	6,50	-	-	-
2	-	9,20	-	-	-
2	-	5,50	-	-	-
1	-	6,80	-	-	-



FLORIM OVERSIZE
magnUm[®]

IMBALLI E DECORI

PACKAGING AND DECORATIONS
EMBALLAGES ET DÉCORS
VERPACKUNGEN UND DEKORS
EMBALAJES Y DECORACIONES

TABELLA IMBALLI

PACKAGE TABLE/TABLEAU DE EMBALLAGES/TABELLE FORMATE/TABLA DE LOS EMBALAJES
#6 SPESSORE / THICKNESS/ÉPAISSEUR/STÄRKE/ESPESOR

			BOXES 				PALLET 		
			ML	PZ	MQ	KG	BOX	MQ	KG
	80x80	31 1/2"x31 1/2"	-	3	1,92	27,80	40	76,80	1140
	60x120	23 5/8"x47 1/4"	-	3	2,16	31,30	30	64,80	960
MOSAICO 1,5x3	30x30	11 4/5"x11 4/5"	-	11	1,00	16,50	-	-	-
MOSAICO 7,5x7,5	30x30	11 4/5"x11 4/5"	-	11	1,00	16,50	-	-	-
MURETTO 7,5x15	30x30	11 4/5"x11 4/5"	-	11	1,00	16,50	-	-	-
BATTISCOPIA	4,6x80	1 4/5"x31 1/2"	14,40	18	-	8,60	-	-	-
	4,6x60	1 4/5"x23 5/8"	14,40	24	-	8,60	-	-	-

DECORI/ DECORS

Note Imballo. Tutti i singoli pezzi tagliati vengono numerati con applicazione sulla parte a vista di un pezzo di nastro isolante dove è riportato il n° del pezzo. Le scatole sono rivestite internamente di polistirolo per garantire l'integrità dei singoli pezzi. Su ogni scatola è riportato: N° dei pezzi totali - Numerazione di ciascun pezzo. Sulla palette viene applicata una pallet card ed una busta in plastica contenente lo schema di montaggio. Per richieste di formati inferiori al modulo base (120x240 o 160x240), resta in vigore la richiesta di lavorazioni fuori standard. N. B. Il prezzo di listino del decoro si riferisce a formato standard. Eventuali lavorazioni su misura verranno valutate su richiesta. (Il servizio clienti è a disposizione per informazioni e ulteriori dettagli a riguardo).

Packing notes. Each individual cut piece is given a number. The piece number is shown on the exposed side of a strip of insulation tape. The boxes are padded on the inside with polystyrene to protect the individual pieces. Each box bears the following information: Total n° of pieces - Code number of each piece. The pallet comes with a pallet card and a plastic pouch containing the assembly diagram. For smaller sizes requests different from basic modules (120x240 or 160x240), you need to follow the procedure for requesting a non-standard format. N. B. The decor's price list refers to the standard format featuring one colour. Any custom-work will be assessed upon request. Please call our Customer Service for more information.

Remarques concernant l'emballage. Chaque pièce découpée est numérotée avec une application sur la partie visible d'un morceau de ruban isolant sur lequel figure le n° de la pièce. Les boîtes sont revêtues intérieurement de polystyrène afin de garantir l'intégrité de chaque pièce. Sur chaque boîte figurent: le nombre de pièces totales et la numérotation de chaque pièce. Une carte de la palette et un sachet en plastique contenant le schéma de montage sont appliqués sur la palette. Pour toute demande de formats inférieurs au module de base (120x240 ou 160x240), reste en vigueur la demande de hors standard. N. B. Le prix catalogue du décor se réfère au format standard. Les éventuels traitements sur mesure seront évalués sur demande. Le service clientèle est à votre disposition si vous avez besoin d'informations et de plus amples détails.

Verpackungshinweise. Alle geschnittenen einzelnen Teile werden nummeriert, wobei die Nummer des Teils auf der sichtbaren Seite eines Stücks Isolierband angebracht ist. Die Kartonverpackungen sind innen mit Polystyrol ausgelegt, um die Unversehrtheit der einzelnen Teile zu gewährleisten. Folgende Angaben befinden sich auf jedem Karton: Gesamtzahl der Teile Nummerierung jedes Teils. An der Palette sind eine Palettenkarte und ein Kunststoffbeutel mit dem Montageplan angebracht. Für Anfragen von kleineren Formaten als vom Standard vorgesehen (120x240 oder 160x240) gilt der übliche Bearbeitungsvorgang für Sonderanfertigungen. N. B. Der Listenpreis bezieht sich auf die Dekoration im Standard-Format, einfarbig. Eventuelle kundenspezifische Verarbeitungen werden auf Anfrage kalkuliert. Der Kundenservice steht für weitere Informationen und Einzelheiten hierzu jederzeit zur Verfügung.

Notas sobre el embalaje. Todas las partes cortadas se enumeran colocando en la parte a la vista de la pieza una cinta adhesiva donde se reproduce el n.º de la pieza. El interior de las cajas se reviste con poliestireno para garantizar la integridad de cada una de las piezas. Sobre cada caja se reproduce: N.º de las piezas totales - Numeración de cada pieza. En la paleta se coloca una "pallet card" y una bolsa plástica que contiene el esquema del montaje. Para pedidos de formatos inferiores a los módulos de base (120x240 o 160x240), es necesario solicitar las elaboraciones no estándar. N. B. El precio de catálogo del decoro se refiere al formato estándar. Las elaboraciones a medida se evaluarán bajo pedido. El servicio de atención al cliente está a su disposición para proporcionarle más información y detalles al respecto.

Listino IMBALLI / Price List PACKAGING	
TIPO / TYPE	PREZZO / PRICE
A: CASSA / CRATE cm 175x340x31h - 68 ^{8/9"} x133 ^{6/7"} x12 ^{1/5"}	230,00 €
B: CASSA / CRATE cm 145x292x35h - 57"x115"x13 ^{7/9"}	160,00 €
C: CASSA / CRATE cm 136x263x34h - 53 ^{1/2"} x103 ^{1/2"} x13 ^{2/5"}	160,00 €
D: CASSA / CRATE cm 135x144x41h - 53 ^{1/7"} x56 ^{2/3"} x16 ^{1/7"}	-
E: CASSA / CRATE cm 135x144x66h - 53 ^{1/7"} x56 ^{2/3"} x26"	-
F: CASSA / CRATE cm 96x262x43h - 37 ^{4/5"} x103 ^{1/7"} x17"	160,00 €
G: CASSA / CRATE cm 174x183x41h - 68 ^{1/2"} x72x16 ^{1/7"}	160,00 €
H/I: CAVALLETTO / A-FRAME cm 73x330x200h - 28 ^{3/4"} x130"x78 ^{3/4"}	360,00 €
L: CAVALLETTO / A-FRAME cm 75x339x186h - 29 ^{1/2"} x133 ^{1/2"} x73 ^{2/9"}	500,00 €
M: CAVALLETTO / A-FRAME cm 75x290x146h - 29 ^{1/2"} x114 ^{1/6"} x57 ^{1/2"}	450,00 €
N/O: CAVALLETTO / A-FRAME cm 75x250x146h - 29 ^{1/2"} x98 ^{3/7"} x57 ^{1/2"}	380,00 €
P/Q: CAVALLETTO / A-FRAME cm 75x250x160h - 29 ^{1/2"} x98 ^{3/7"} x63"	280,00 €
R: CAVALLETTO / A-FRAME cm 75x170x195h - 29 ^{1/2"} x67"x76 ^{7/9"}	280,00 €

*Le lastre sono contenute in scatole da 2 pezzi ciascuna / Packing for this item is 2 slabs per box / Les plaques sont contenues dans des boîtes de 2 pièces chacune. Die Platten sind in Kartons zu je 2 Stück verpackt. / Las baldosas están empaquetadas en cajas de 2 piezas cada una.

°per spedizioni >12 scatole / for shipments >12 boxes / pour les expéditions >12 boîtes / für Versandmengen >12 Schachteln / para envíos > 12 cajas

°per spedizioni ≤12 scatole / for shipments ≤12 boxes / pour les expéditions ≤12 boîtes / für Versandmengen ≤12 Schachteln / para envíos ≤12 cajas

TABELLA IMBALLI

PACKAGE TABLE/TABLEAU DE EMBALLAGES/TABELLE FORMATE/TABLA DE LOS EMBALAJES

≠6 SPESSORE / THICKNESS/ÉPAISSEUR/STÄRKE/ESPESOR

TIPO TYPE	formato LASTRA SLAB size	LASTRA SLAB		CASSA vuota empty CRATE			CASSA piena full CRATE	CAVALLETTO vuoto empty A-Frame			CAVALLETTO pieno full A-Frame
		MQ	KG	PZ	MQ	KG	KG	PZ	MQ	KG	KG
	A 160x320 63"x126"	5,12	74,15	14	71,68	140,5	1178,6	-	-	-	-
	B 120x280 47 ^{1/4} "x110 ^{1/4} "	3,36	48,65	20	67,20	90,00	1063	-	-	-	-
	C 120x240 47 ^{1/4} "x94 ^{1/2} "	2,88	41,70	20	57,60	107,00	941	-	-	-	-
	D 120x120 47 ^{1/4} "x47 ^{1/4} "	1,44	20,85	24*	34,56	50,00	550	-	-	-	-
	E 6mm 120x120 47 ^{1/4} "x47 ^{1/4} "	1,44	20,70	48*	69,12	70	1065,1	-	-	-	-
	F 80x240 31 ^{1/2} "x94 ^{1/2} "	1,92	27,80	30	57,60	97,00	931	-	-	-	-
	G 160x160 63"x63"	2,56	37,06	24	61,44	45,00	934,44	-	-	-	-
	H 160x320 63"x126"	5,12	74,15	-	-	-	-	44	225,28	220,00	3482,6
	I 120x280 47 ^{1/4} "x110 ^{1/4} "	3,36	48,65	-	-	-	-	44	147,84	220,00	2360,6
	L 160x320 63"x126" Cavalletto in lamiera zincata Zinc-plated sheet A-frame	5,12	74,15	-	-	-	-	44	225,28	120,00	3382,6
	M 120x280 47 ^{1/4} "x110 ^{1/4} " Cavalletto in lamiera zincata Zinc-plated sheet A-frame	3,36	48,65	-	-	-	-	44	147,84	108,5	2249,1
	N 120x240 47 ^{1/4} "x94 ^{1/2} " Cavalletto in lamiera zincata Zinc-plated sheet A-frame	2,88	41,70	-	-	-	-	44	126,72	92,5	1941,5
	O 80x240 31 ^{1/2} "x94 ^{1/2} " Cavalletto in lamiera zincata Zinc-plated sheet A-frame	1,92	27,80	-	-	-	-	28	84,48	92,5	1325,5
	P 120x240 47 ^{1/4} "x94 ^{1/2} "	2,88	41,70	-	-	-	-	44	126,72	170,00	2004,8
	Q 80x240 31 ^{1/2} "x94 ^{1/2} "	1,92	27,80	-	-	-	-	44	84,48	170,00	1393,2
	R 160x160 63"x63"	2,56	37,07	-	-	-	-	44	112,64	160,00	1791,08

ESEMPI DI PERSONALIZZAZIONE DECORI IN DIMENSIONE 120X240

EXAMPLES OF DECORS CUSTOMIZATIONS 120X240 SIZE

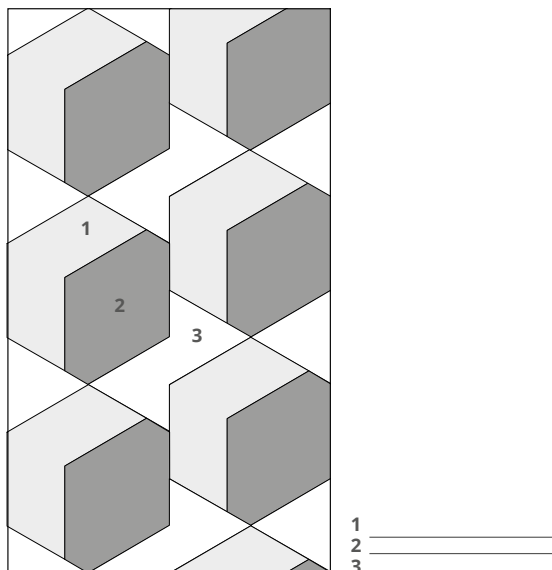

In ogni decoro è possibile selezionare materie e superfici combinandole nel modo in cui si desidera (vedi esempio).
Il decoro può essere adattato a qualsiasi misura richiesta.

For each decor you can select materials and surfaces combining them in the way you prefer (see example).
The decoration can be adapted to any requested measurements.

ABBINAMENTI CONSIGLIATI.

SUGGESTED COMBINATIONS.

I CLASSICI MATIÈRES

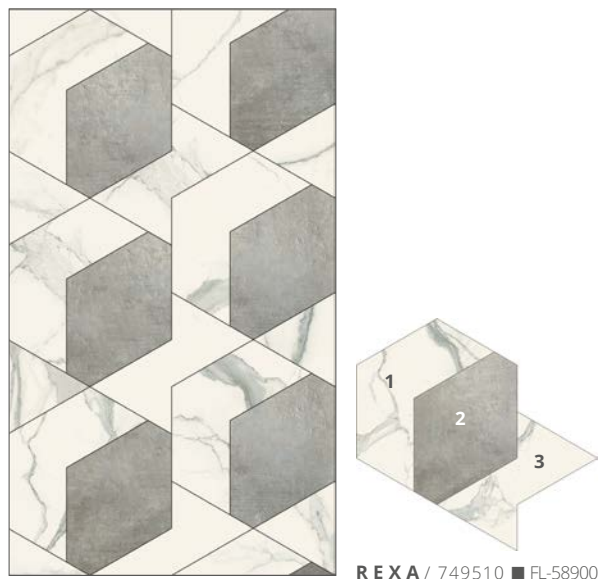

1 / I CLASSICI / STATUARIO
2 / MATIÈRES / MATIÈRES NUAGE
3 / I CLASSICI / STATUARIO

ESEMPI DI PERSONALIZZAZIONE DECORI

EXAMPLES OF DECORS CUSTOMIZATIONS

PREXIOUS MATIÈRES



1/ **PREXIOUS** / DREAM ARABESQUE
2/ **MATIÈRES** / MATIÈRES MOU
3/ **PREXIOUS** / DREAM ARABESQUE

ÉTOILE MATIÈRES

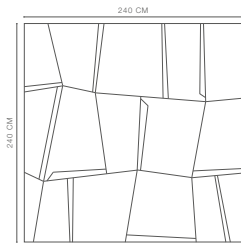

REXB / 749511 ■ FL-58900

1/ **ÉTOILE** / ÉTOILE SYMPHONIE
2/ **MATIÈRES** / MATIÈRES MOU

LES BIJOUX I CLASSICI

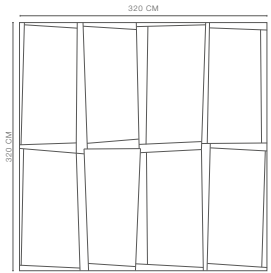

REXC / 749512 ■ FL-58900

1/ **I CLASSICI** / MARQUINIA
2/ **LES BIJOUX** / CALACATTA ALTISSIMO BLANC

ESEMPI DI PERSONALIZZAZIONE DECORI IN DIMENSIONE 120X240

EXAMPLES OF DECORS CUSTOMIZATIONS 120X240 SIZE

I CLASSICI



REXF / 749513 ■ FL-58900

I CLASSICI / CALACATTA GOLD

**LES BIJOUX
MATIÈRES**

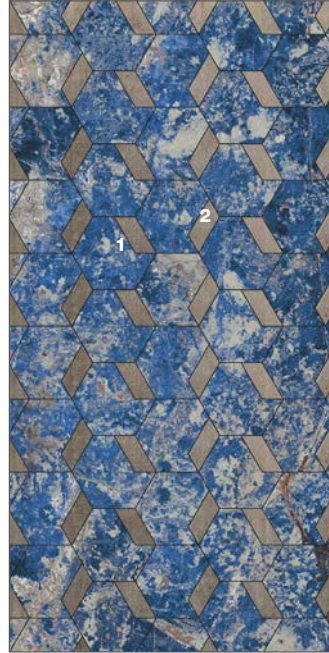

REXG / 749514 ■ FL-58900

**1/ LES BIJOUX / SODALITE BLEU
2/ MATIÈRES / MATIÈRES NUAGE**

ARDOISE



REXH / 749524 ■ FL-58900

**1/ ARDOISE / BLANC
2/ ARDOISE / ECRU
3/ ARDOISE / GRIS
4/ ARDOISE / NOIR**

I CLASSICI



REXI / 749525 ■ FL-58900

**1/ I CLASSICI / STATUARIO SOFT
2/ I CLASSICI / STATUARIO GLOSSY**

ESEMPI DI PERSONALIZZAZIONE DECORI IN DIMENSIONE 120X240

EXAMPLES OF DECORS CUSTOMIZATIONS 120X240 SIZE

RÊVES



REXL / 749526 ■ FL-58900

- 1/ RÊVES / RÊVE NOISETTE
- 2/ RÊVES / RÊVE NOISETTE
- 3/ RÊVES / RÊVE CHOCO
- 4/ RÊVES / RÊVE CHOCO

**RÊVES
I CLASSICI**

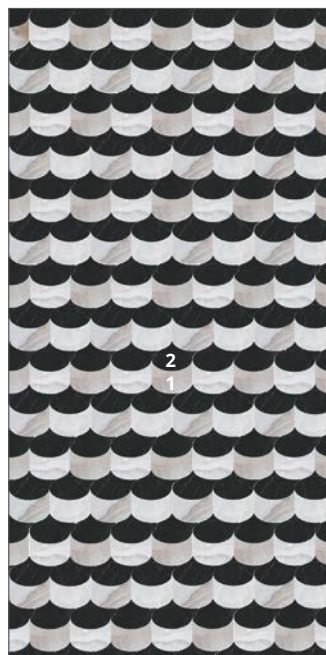

REXM / 749527 ■ FL-58900

- 1/ RÊVES / RÊVE BLEU GLOSSY
- 2/ I CLASSICI / MARQUINIA GLOSSY

MATIÈRES



REXO / 749530 ■ FL-58900

- 1/ MATIÈRES / MATIÈRES GRIS
- 2/ MATIÈRES / MATIÈRES NUAGE
- 3/ MATIÈRES / MATIÈRES SABLE

ESEMPI DI PERSONALIZZAZIONE DECORI IN DIMENSIONE 120X240

EXAMPLES OF DECORS CUSTOMIZATIONS 120X240 SIZE

LA ROCHE



1/ LA ROCHE / LA ROCHE BLANC
2/ LA ROCHE / LA ROCHE GREY



REXN / 749528 ■ FL-58900

PREXIOUS



1/ PREXIOUS / THUNDER NIGHT
2/ PREXIOUS / THUNDER NIGHT
3/ PREXIOUS / WHITE FANTASY
4/ PREXIOUS / WHITE FANTASY



REXP / 749529 ■ FL-58900

ESEMPI DI PERSONALIZZAZIONE DECORI IN DIMENSIONE 265X240

EXAMPLES OF DECORS CUSTOMIZATIONS 265X240 SIZE

I CLASSICI



I CLASSICI / CALACATTA GOLD

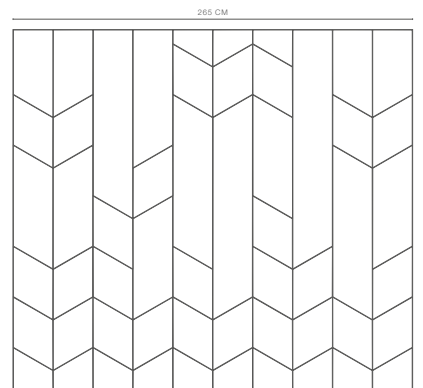

REXQ / 749531 ■ FL-58900

ESEMPI DI PERSONALIZZAZIONE DECORI
EXAMPLES OF DECORS CUSTOMIZATIONS

ARDOISE



REXE A/B/C / 750218 ■ FL-58900



1 / ARDOISE / BLANC
2 / ARDOISE / GRIS

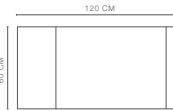

REXE A / 749515 ■ FL-58900



1 / ARDOISE / BLANC
2 / ARDOISE / GRIS

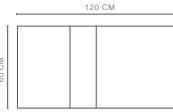

REXE B / 749516 ■ FL-58900



1 / ARDOISE / BLANC
2 / ARDOISE / GRIS

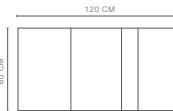

REXE C / 749517 ■ FL-58900

LA ROCHE



LA ROCHE / LA ROCHE ECRU

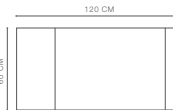

LA ROCHE / LA ROCHE ECRU

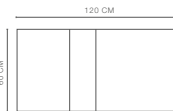

LA ROCHE / LA ROCHE ECRU

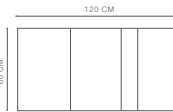

ESEMPI DI PERSONALIZZAZIONE DECORI IN DIMENSIONE 160X240

EXAMPLES OF DECORS CUSTOMIZATIONS 160X240 SIZE

MATIÈRES



REXD A/B/C/D/E/F / 750217
■ FL-58900

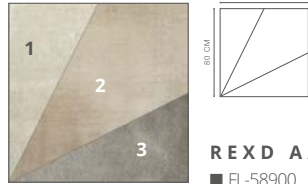

REXD A / 749518
■ FL-58900

- 1/ MATIÈRES / MATIÈRES SABLE
- 2/ MATIÈRES / MATIÈRES MOU
- 3/ MATIÈRES / MATIÈRES GRIS



REXD B / 749519
■ GFL-58900

- 1/ MATIÈRES / MATIÈRES SABLE
- 2/ MATIÈRES / MATIÈRES MOU
- 3/ MATIÈRES / MATIÈRES GRIS
- 4/ MATIÈRES / MATIÈRES NUAGE

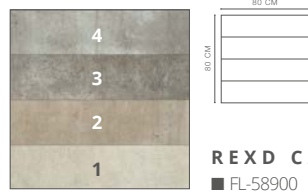

REXD C / 749520
■ FL-58900

- 1/ MATIÈRES / MATIÈRES SABLE
- 2/ MATIÈRES / MATIÈRES MOU
- 3/ MATIÈRES / MATIÈRES GRIS
- 4/ MATIÈRES / MATIÈRES NUAGE

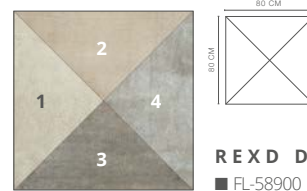

REXD D / 749521
■ FL-58900

- 1/ MATIÈRES / MATIÈRES SABLE
- 2/ MATIÈRES / MATIÈRES MOU
- 3/ MATIÈRES / MATIÈRES GRIS
- 4/ MATIÈRES / MATIÈRES NUAGE

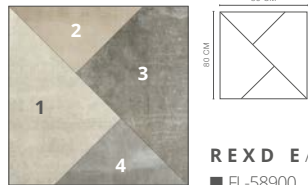

REXD E / 749522
■ FL-58900

- 1/ MATIÈRES / MATIÈRES SABLE
- 2/ MATIÈRES / MATIÈRES MOU
- 3/ MATIÈRES / MATIÈRES GRIS
- 4/ MATIÈRES / MATIÈRES NUAGE

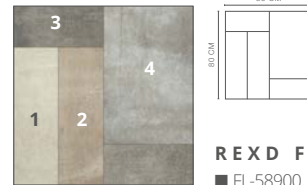

REXD F / 749523
■ FL-58900

- 1/ MATIÈRES / MATIÈRES SABLE
- 2/ MATIÈRES / MATIÈRES MOU
- 3/ MATIÈRES / MATIÈRES GRIS
- 4/ MATIÈRES / MATIÈRES NUAGE

FLORIM OVERSIZE
magnUm[®]

MODERN DESIGN
PERSPECTIVES ARE
CHANGING: AMAZING
SIZES IN A THICKNESS
OF JUST 6 MM,
LIGHT, VERSATILE
AND STRONG, WITH
EXTRAORDINARY
AESTHETIC APPEAL.

GRAPHICS

ARDOISE

BLANC



ECRU



GRIS



NOIR

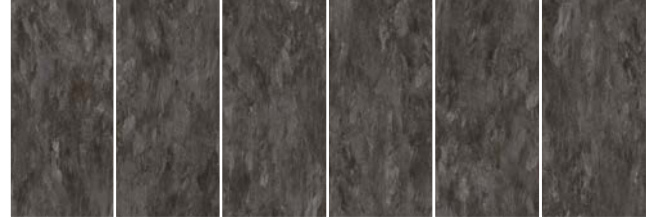

ÉTOILE

ÉTOILE RENOIR



ÉTOILE GRIS



ÉTOILE CRÈME



ÉTOILE ILLUSION

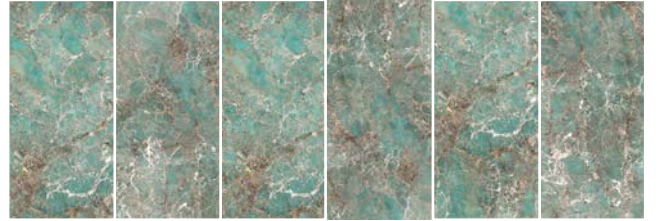

ÉTOILE SYMPHONIE

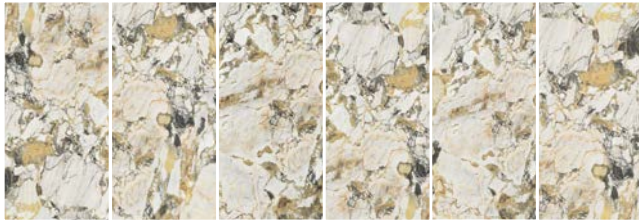

LA ROCHE

LA ROCHE BLANC



LA ROCHE ECRU



LA ROCHE GREY



I CLASSICI

STATUARIO

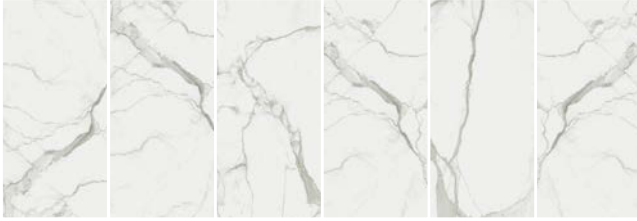

CALACATTA GOLD



MARQUINIA



LES ORIGINES

ORIGINES OR



ORIGINES ARGENT



ORIGINES BLANC

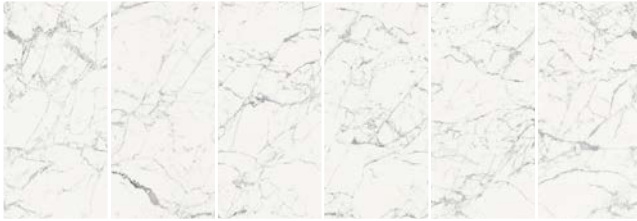

ORIGINES OMBRE DORÉE



RÊVES

RÊVE PERLE



RÊVE BLEU



RÊVE NOISETTE

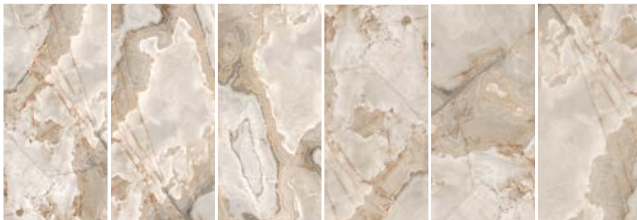

RÊVE CHOCO



RÊVE ROSE



RÊVE JADE

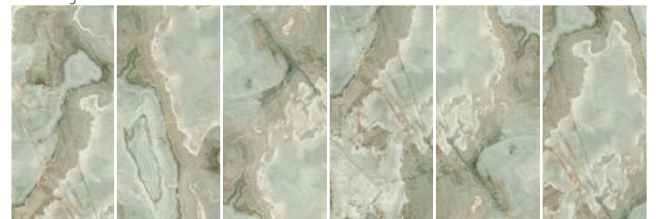

PREXIOUS

WHITE FANTASY

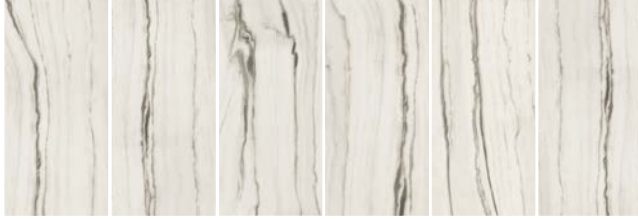

DREAM ARABESQUE



CHARMING AMBER

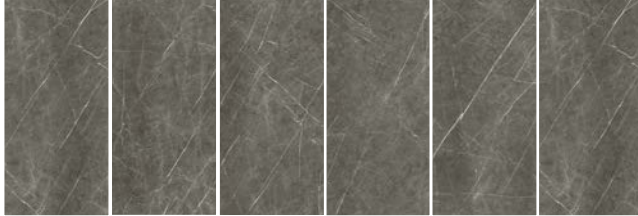

THUNDER NIGHT



HERITAGE LUXE

HERITAGE CLOUD



HERITAGE AZURE

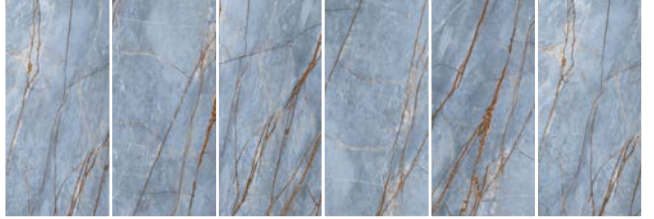

HERITAGE BROWN



HERITAGE EMERALD



HERITAGE AQUA



HERITAGE FLAME



Le immagini riportate non rappresentano necessariamente il numero di grafiche del prodotto. Il numero di grafiche è variabile in funzione del formato e del colore di riferimento.
Images do not necessarily represent the number of patterns in the product's range. The number of different patterns varies according to size and color of the item. / Les images reportées ne représentent pas forcément le nombre de graphismes du produit. Leur nombre varie en fonction du format et de la couleur choisie. / Die Abbildungen geben keine bindende Auskunft bzgl. der Anzahl verschiedener Grafiken. Die Anzahl der Grafiken ist abhängig von Format und Farbe der jeweiligen Kollektion. / Las imágenes mostradas no representan necesariamente el número de gráficas del producto. El número de gráficas varía en función del formato y del color.

MATIÈRES

MATIÈRES SABLE



MATIÈRES NUAGE



MATIÈRES GRIS



MATIÈRES MOU



LES BIJOUX

CALACATTA ALTISSIMO BLANC



ONYX BLANCHE

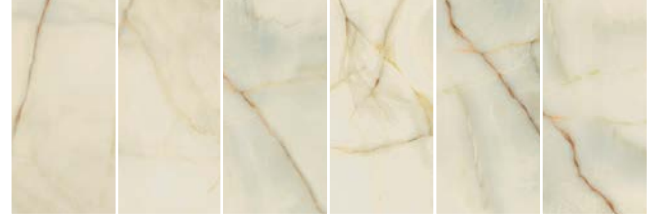

OMBRE DE CARAVAGE

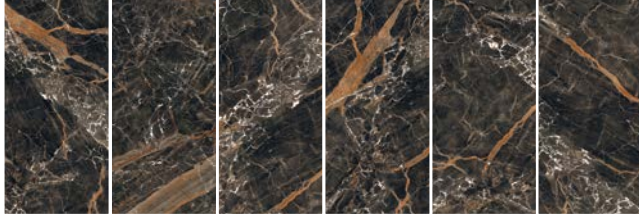

BRÈCHE CAPRAIA

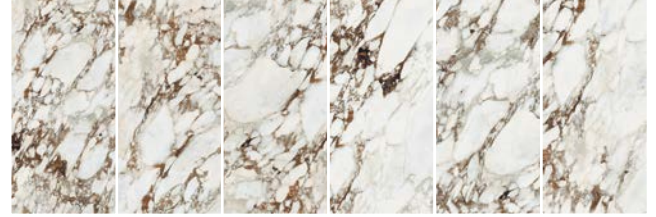

MARRON IMPERIAL



JASPE ROUGE

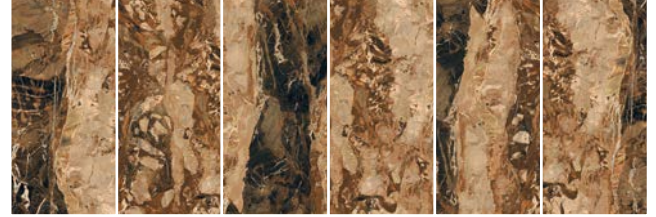

SODALITE BLEU

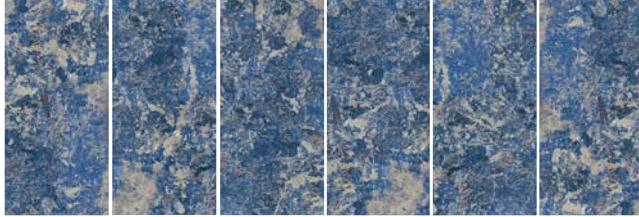

LES QUATRE SAISONS

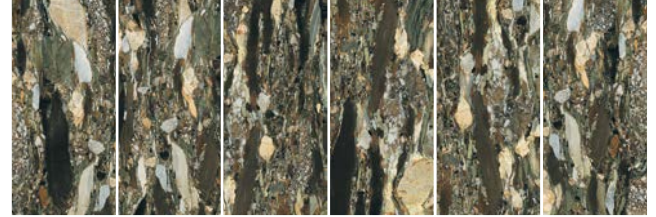

CARATTERISTICHE TECNICHE

TECHNICAL FEATURES
CARACTÉRISTIQUES TECHNIQUES
TECHNISCHE EIGENSCHAFTEN
CARACTERISTICAS TÉCNICAS

6mm

LES ORIGINES - ÉTOILE - RÊVES

GRES PORCELLANATO COLORATO IN MASSA
 COLOURED BODY PORCELAIN STONEWARE - GRÉS CÉRAME COLORE DANS LA MASSE - DURCHFARBTE FEINSTEINZEUG - GRES PORCELÁNICO COLOREADO EN MASA
 SQUADRATO - SQUARED - EQUARRI - REKTIFIZIERT - ESCUADRADO

6 mm 1/4" ↑

CARATTERISTICHE TECNICHE - TECHNICAL CHARACTERISTICS - CARACTERISTIQUES TECHNIQUES - TECHNISCHE EIGENSCHAFTEN - CARACTERÍSTICAS TÉCNICAS									
Prestazioni e caratteristiche tecniche		PRESCRIZIONE STANDARD REQUIREMENTS PRESCRIPTIONS ANFORDERUNGEN PRESCRIPCION		RISULTATI TESTS TEST RESULTS RESULTATS DES ESSAIS PRÜFERERGEBNIS RESULTADOS TESTS			RIFERIMENTO NORMA REFERENCE STANDARD RÉFÉRENCE NORME STANDARDWERT REFERENCIA NORMA		
		(%)	(mm)	LES ORIGINES	ÉTOILE	RÊVES			
Piastrelle di ceramica pressate a secco. Caratteristiche di qualità secondo i test di controllo previsti dalla norma EN 14411-ISO 13006 Appendice G gruppo Bla GL / Dry-pressed ceramic tiles. Quality specifications, according to control tests of EN 14411-ISO 13006 Appendix G group Bla GL / Carreaux céramiques pressés à sec. Caractéristiques de qualité d'après les essais de contrôle norme EN 14411-ISO 13006 Annexe G Groupe Bla GL / Trocken gepresste Keramikfliesen. / Qualitätseigenschaften nach Normen EN 14411-ISO 13006 Anlage G Gruppe Bla GL / Baldosas de cerámica prensadas en seco. Características de calidad según las Normas EN 14411-ISO 13006 Apéndice G grupo Bla GL.		N ≥ 15 cm							
	LUNGHEZZA E LARGHEZZA: DEVIAZIONE AMMISSIBILE, IN %, DELLA DIMENSIONE MEDIA DI OGNI PIASTRELLA DALLA DIM. DI FABBRICAZIONE / LENGTH AND WIDTH: ADMITTED DEVIATION, IN %, OF THE AVERAGE SIZE OF EACH TILE FROM THE PRODUCTION DIMENSIONS / LONGUEUR ET LARGEUR : MARGE DE TOLÉRANCE, EN %, ENTRE LA DIMENSION MOYENNE DE CHAQUE CARREAU ET LA DIM. DE FABRICATION / LANGE UND BREITE: ZULÄSSIGE ABWEICHUNG DES DURCHSCHNITTMABES JEDER FLIESE VOM HERSTELLMAB IN PROZENTEN / LARGO Y ANCHO: DESVIACIÓN ADMISIBLE, EN %, DEL TAMAÑO MEDIO DE CADA BALDOSA A PARTIR DEL TAMAÑO DE FABRICACIÓN	Squadrato ISO 13006	±0,3%	±1,0mm		±0,15%	ISO 10545-2		
	DEVIAZIONE AMMISSIBILE, IN PERCENTO, DELLO SPESSORE MEDIO DI OGNI PIASTRELLA DALLA DIMENSIONE DI FABBRICAZIONE / ADMITTED DEVIATION, IN %, OF THE AVERAGE THICKNESS OF EACH TILE FROM THE PRODUCTION DIMENSIONS / MARGE DE TOLÉRANCE, EN POURCENTAGE, ENTRE L'ÉPAISSEUR MOYENNE DE CHAQUE CARREAU ET LA DIMENSION DE FABRICATION / ZULÄSSIGE ABWEICHUNG DER DURCHSCHNITTSDICKE JEDER FLIESE VOM HERSTELLMAB IN PROZENTEN / DESVIACIÓN ADMISIBLE, EN TANTO POR CIENTO, DEL GROSOR MEDIO DE CADA BALDOSA A PARTIR DEL TAMAÑO DE FABRICACIÓN	-	±5%	±0,5mm		±5%	ISO 10545-2		
	DEVIAZIONE MASSIMA DI RETTILINEARITÀ, IN PERCENTO, IN RAPPORTO ALLE DIMENSIONI DI FABBRICAZIONE CORRISPONDENTI / MAXIMUM STRAIGHTNESS DEVIATION, IN %, IN RELATION TO THE CORRESPONDING PRODUCTION DIMENSIONS / MARGE DE TOLÉRANCE DE RECTITUDE, EN POURCENTAGE, PAR RAPPORT AUX DIMENSIONS DE FABRICATION CORRESPONDANTES / ZULÄSSIGE HOCHSTABWEICHUNG DER KANTENGERADHEIT IM VERHÄLTNISS ZU DEN ENTSPRECHENDEN HERSTELLMABEN IN PROZENTEN / DESVIACIÓN MÁXIMA DE RECTITUD, EN TANTO POR CIENTO, EN RELACIÓN CON EL TAMAÑO DE FABRICACIÓN CORRESPONDIENTE	Squadrato ISO 13006	±0,3%	±0,8mm		±0,1%	ISO 10545-2		
	DEVIAZIONE MASSIMA DI ORTOGONALITÀ, IN PERCENTO, IN RAPPORTO ALLE DIMENSIONI DI FABBRICAZIONE CORRISPONDENTI / MAXIMUM RIGHT-ANGLE DEVIATION, IN %, IN RELATION TO THE CORRESPONDING PRODUCTION DIMENSIONS / MARGE DE TOLÉRANCE D'ANGULARITÉ, EN POURCENTAGE, PAR RAPPORT AUX DIMENSIONS DE FABRICATION / HOCHSTABWEICHUNG DER RECHTWINKLIGKEIT IM VERHÄLTNISS ZU DEN ENTSPRECHENDEN HERSTELLMABEN IN PROZENTEN / DESVIACIÓN MÁXIMA DE LA ORTOGONALIDAD, EN TANTO POR CIENTO, EN RELACIÓN CON EL TAMAÑO DE FABRICACIÓN CORRESPONDIENTE	Squadrato ISO 13006	±0,3%	±1,5mm		±0,2%	ISO 10545-2		
	PLANARITÀ (CURVATURA DEL CENTRO, DELLO SPIGOLO E SVERGOLAMENTO) / FLATNESS (CURVING IN THE MIDDLE, CORNER AND WARPING) / PLANÉITÉ (COURBURE CENTRALE, DE L'ARÊTE ET GAUCHISSEMENT) / EBENFLÄCHIGKEIT (KRÜMMUNG DER MITTE, DER KANTE UND VERWINDUNG) / PLANITUD (CURVATURA DEL CENTRO, DE LA ARISTA Y ABARQUILLAMIENTO)	Squadrato ISO 13006	±0,4%	±1,8mm		±0,2%	ISO 10545-2		
	QUALITÀ DELLA SUPERFICIE - SURFACE QUALITY / QUALITÉ DE LA SURFACE - QUALITÄT DER OBERFLÄCHE / CALIDAD DE LA SUPERFICIE		Il 95% min delle piastrelle deve essere esente da difetti visibili. At least 95% of the tiles must be free from visible flaws. 95% min des carreaux ne doivent présenter aucun défaut visible. Mindestens 95% der Fliesen müssen frei von sichtbaren min. El 95% de las baldosas tiene que estar exento de defectos visibles			CONFORME/CONFORMING CONFORME/KONFORM CONFORME	ISO 10545-2		
	MASSA D'ACQUA ASSORBITA IN % / % WATER ABSORPTION - MASSE D'EAU ABSORBÉE EN % WASSERAUFNAHME IN % MASA DE AGUA ABSORBIDA EN %		< 0,5%			valore medio 0,08%	ISO 10545-3		
	FORZA DI ROTTURA IN N (sp. ≥ 7,5 mm) - BREAKING STRENGTH IN N (thickness ≥ 7,5 mm) / FORCE DE RUPTURE EN N (ép. ≥ 7,5 mm) / BRUCHLAST IN N (Dicke ≥ 7,5 mm) / FUERZA DE ROTURA EN N (gr. ≥ 7,5 mm)		≥ 700			valore medio 1350 Newton	ISO 10545-4		
	RESISTENZA ALLA FLESSIONE IN N/mm2 / N/mm2 FLEXURAL STRENGTH TEST / RÉSISTANCE A LA FLEXION EN N/mm2 / BIEGESTÄRKE IN N/mm / RESISTENCIA A LA FLEXIÓN EN N/mm		35 MIN.			valore medio 52 N/mm2	ISO 10545-4		
	RESISTENZA ALL'ABRASIONE DELLE PIASTRELLE SMALTATE / RESISTANCE TO ABRASION OF GLAZED TILES / RÉSISTANCE À L'ABRASION DES CARREAUX ÉMAILLÉS / TIEFENABRIEBFESTIGKEIT GLASIERTER FLIESEN / RESISTENCIA A LA ABRASION DE LAS BALDOSAS ESMALTADAS	come dichiarato dal produttore see manufacturer's declaration selon déclaration du producteur entsprechend der herstellereangaben tal como declara el fabricante					ISO 10545-7		
	RESISTENZA AGLI SBALZI TERMICI / THERMAL SHOCKS RESISTANT / RÉSISTANCE AUX VARIATIONS THERMIQUES TEMPERATURWECHSELBESTÄNDIGKEIT / RESISTENCIA AL CHOQUE TÉRMICO	Metodo di prova disponibile/Available testing method Méthode d'essai disponible/Verfügbare Prüfmethode Método de ensayo disponible				RESISTE - RÉSISTANT RESISTE - ERFÜLLT RESISTE	ISO 10545-9		
	RESISTENZA AL GELO / FROST RESISTANCE - RÉSISTANCE AU GEL / FROSTSICHERHEIT - RESISTENCIA A LA HELADA	richiesta - required requise - gefordert requerida				RESISTE - RÉSISTANT RESISTE - ERFÜLLT RESISTE	ISO 10545-12		
	RESISTENZA ALLE MACCHIE / RESISTANCE TO STAINING / RÉSISTANCE AUX TACHES / FLECKENABWEISEND RESISTENCIA A LAS MANCHAS	Metodo di prova disponibile Available testing method Méthode d'essai disponible Verfügbare Prüfmethode Método de ensayo disponible			Classe 5 MATTE	Classe 3-4	Classe 5 MATTE Classe 4 GLOSSY	ISO 10545-14	
	RILASCIO DI SOSTANZE PERICOLOSE / RELEASE OF HAZARDOUS SUBSTANCES / REJET DE SUBSTANCES DANGEREUSES / FREISZETZUNG GEFÄHRLICHER STOFFE / LIBERACION DE SUSTANCIAS PELIGROSAS CADMIO (in mg/dm ²) - PIOMBO (in mg/dm ²)	valore dichiarato per superfici GL con impieghi su piani di lavoro declared value for GL surfaces used on worktops valeur déclarée pour surfaces GL utilisées sur plans de travail angegebener wert für GL oberflächen zum gebrauch als arbeitsplatten valor declarado para acabados GL utilizados para superficies de trabajo				CONFORME/CONFORMING CONFORME/KONFORM/CONFORME	DM-1-2-2007-Reg-CE-1935-2004		
	RESISTENZA A BASSE CONCENTRAZIONI DI ACIDI E ALCALI. / RESISTANCE TO LOW CONCENTRATIONS OF ACIDS AND ALKALIS. / RESISTANCE A BASSES CONCENTRATIONS D'ACIDES ET ALCALIS. / WIDERSTAND GEGEN NIEDRIGE KONZENTRATIONEN VON SAUREN UND LAUGEN. / RESISTENCIA A BAJAS CONCENTRACIONES DE ACIDOS Y ALCALIS. /	come dichiarato dal produttore see manufacturer's declaration selon déclaration du producteur entsprechend der herstellereangaben tal como declara el fabricante			GLA MATTE	GLA MATTE	GLA MATTE	ISO 10545-13	
	RESISTENZA AI PRODOTTI CHIMICI DI USO DOMESTICO E AGLI ADDITIVI PER PISCINA / RESISTENCE TO DOMESTIC CHEMICAL PRODUCTS AND ADDITIVES FOR SWIMMING POOLS / RÉSISTANT AUX PRODUITS CHIMIQUES À USAGE DOMESTIQUE ET AUX ADDITIFS POUR PISCINE / WIDERSTAND GEGEN HAUSHALTSCHIMIKALIEN UND SCHWIMMBADZUSATZSTOFFEN / RESISTENCIA A PRODUCTOS PARA LIMPIEZA DOMESTICA Y ADITIVOS PARA PISCINAS	MIN B			GLB GLOSSY	GLB GLOSSY	GLB GLOSSY		
	RESISTENZA AL CAVILLO DI PIASTRELLE SMALTATE / GLAZE CRAZING RESISTANCE - RÉSISTANCE AU TRESSAILLAGE POUR LES CARREAUX ÉMAILLÉS / WIDERSTAND GEGEN HAARRISS VON GLASIERTEN FLIESEN - RESISTENCIA AL CUARTEADO DE LOS AZULEJOS ESMALTADOS	richiesta - required requise - gefordert requerida				RESISTE - RÉSISTANT RESISTE - ERFÜLLT RESISTE	ISO 10545-11		
	COEFFICIENTE D'ATTRITO (SCIVOLOSITÀ) / FRICTION COEFFICIENT (SLIPPERINESS) / COEFFICIENT DE FRICTION (GLISSEMENT) / REIBUNGSKOEFFIZIENT (SCHLÜPFRIEGKEIT) - COEFICIENTE DE ANTI DESLIZAMIENTO	-			>0,42 wet MATTE	>0,42 wet MATTE	>0,42 wet MATTE	DCOF (section 9.6 ANSI A 137.1.2012)	

Per un effetto ottimale della posa, florim suggerisce di mantenere 2 mm di fuga per pose monofornate e 3 mm per combinare formati misti / For optimal installation results, florim recommends maintaining a joint of 2 mm 1/12" for single format installations and 3 mm 1/8" to combine mixed formats / Pour réaliser une pose parfaite, florim suggère de maintenir 2 mm de joint pour la pose des monofornats, et 3 mm pour les combinaisons de formats mixtes / Um einen optimalen effekt beim verlegen zu erzielen empfiehlt florim eine 2 mm fugen bei einformatigen verlegungen und 3 mm fugen bei formatkombinationen / Para lograr los máximos resultados en la posa del producto, florim aconseja 2 mm de junta en combinaciones de formatos mixtos.

I CLASSICI - LES BIJOUX - PREXIOUS

GRES PORCELLANATO COLORATO IN MASSA/QUADRATO - COLOURED BODY PORCELAIN STONWARE/SQUARED - GRÈS CÉRAME COLORE DANS LA MASSE/EQUARRI DURCHGEFÄRBT FEINSTEINZEUG/REKTIFIZIERT - GRES PORCELÁNICO COLOREADO EN MASA/ESCUADRADO

6 mm 1/4" ↑↓

CARATTERISTICHE TECNICHE - TECHNICAL CHARACTERISTICS - CARACTERISTIQUES TECHNIQUES - TECHNISCHE EIGENSCHAFTEN - CARACTERÍSTICAS TÉCNICAS		PRESCRIZIONE STANDARD REQUIREMENTS PRESCRIPTIONS ANFORDERUNGEN PRESCRIPTION		RISULTATI TESTS TEST RESULTS RESULTATS DES ESSAIS PRÜFERGEBNIS RESULTADOS TESTS			RIFERIMENTO NORMA REFERENCE STANDARD REFERENCIA NORMA STANDARDWERT REFERENCIA NORMA
		N ≥ 15 cm		I CLASSICI	LES BIJOUX	PREXIOUS	
		(%)	(mm)				
Piastrille di ceramica pressate a secco. Caratteristiche di qualità secondo i test di controllo previsti dalla norma EN 14411-ISO 13006 Appendice G gruppo Bla GL / Dry-pressed ceramic tiles. Quality specifications, according to control tests of EN 14411-ISO 13006 Appendix G group Bla GL / Carreaux céramiques pressés à sec. Caractéristiques de qualité d'après les essais de contrôle norme EN 14411-ISO 13006 Appendice G groupe Bla GL / Trocken gepresste Keramikfliesen / Qualitätseigenschaften nach Normen EN 14411-ISO 13006 Anhang G Gruppe Bla GL / Baldosas de cerámica prensadas en seco. Características de calidad según las Normas EN 14411-ISO 13006 Apéndice G grupo Bla GL.		Squadrato ISO 13006		±0,3%	±1,0mm	±0,15%	ISO 10545-2
LUNGHEZZA E LARGHEZZA: DEVIAZIONE AMMISSIBILE, IN %, DELLA DIMENSIONE MEDIA DI OGNI PIASTRELLA DALLA DIM. DI FABBRICAZIONE / LENGTH AND WIDTH: ADMITTED DEVIATION, IN %, OF THE AVERAGE SIZE OF EACH TILE FROM THE PRODUCTION DIMENSIONS / LONGUEUR ET LARGEUR : MARGE DE TOLÉRANCE, EN %, ENTRE LA DIMENSION MOYENNE DE CHAQUE CARREAU ET LA DIM. DE FABRICATION / LANGE UND BREITE: ZULÄSSIGE ABWEICHUNG DES DURCHSCHNITTMÄßES JEDER FLIESE VOM HERSTELLMAß IN PROZENTEN / LARGO Y ANCHO: DESVIACIÓN ADMISIBILE, EN %, DEL TAMAÑO MEDIO DE CADA BALDOSA A PARTIR DEL TAMAÑO DE FABRICACIÓN		-		±5%	±0,5mm	±5%	ISO 10545-2
DEVIAZIONE AMMISSIBILE, IN PERCENTO, DELLO SPESSORE MEDIO DI OGNI PIASTRELLA DALLA DIMENSIONE DI FABBRICAZIONE / ADMITTED DEVIATION, IN %, OF THE AVERAGE THICKNESS OF EACH TILE FROM THE PRODUCTION DIMENSIONS / MARGE DE TOLÉRANCE, EN POURCENTAGE, ENTRE L'ÉPAISSEUR MOYENNE DE CHAQUE CARREAU ET LA DIMENSION DE FABRICATION / ZULÄSSIGE ABWEICHUNG DER DURCHSCHNITTSDICKE JEDER FLIESE VOM HERSTELLMAß IN PROZENTEN / DESVIACIÓN ADMISIBILE, EN TANTO POR CIENTO, DEL GROSOR MEDIO DE CADA BALDOSA A PARTIR DEL TAMAÑO DE FABRICACIÓN		Squadrato ISO 13006		±0,3%	±0,8mm	±0,1%	ISO 10545-2
DEVIAZIONE MASSIMA DI RETTILINEARITÀ, IN PERCENTO, IN RAPPORTO ALLE DIMENSIONI DI FABBRICAZIONE/CORRISPONDENTI / MAXIMUM STRAIGHTNESS DEVIATION, IN %, IN RELATION TO THE CORRESPONDING PRODUCTION DIMENSIONS / MARGE DE TOLÉRANCE DE RECTITUDE, EN POURCENTAGE, PAR RAPPORT AUX DIMENSIONS DE FABRICATION CORRESPONDANTES / ZULÄSSIGE HOCHSTABWEICHUNG DER KANTENGERADHEIT IM VERHÄLTNIS ZU DEN ENTSPRECHENDEN HERSTELLMÄßEN IN PROZENTEN / DESVIACIÓN MÁXIMA DE RECTITUD, EN TANTO POR CIENTO, EN RELACIÓN CON EL TAMAÑO DE FABRICACIÓN CORRESPONDIENTE		Squadrato ISO 13006		±0,3%	±1,5mm	±0,2%	ISO 10545-2
DEVIAZIONE MASSIMA DI ORTOGONALITÀ, IN PERCENTO, IN RAPPORTO ALLE DIMENSIONI DI FABBRICAZIONE/ CORRISPONDENTI / MAXIMUM RIGHT-ANGLE DEVIATION, IN %, IN RELATION TO THE CORRESPONDING PRODUCTION DIMENSIONS / MARGE DE TOLÉRANCE D'ANGULARITÉ, EN POURCENTAGE, PAR RAPPORT AUX DIMENSIONS DE FABRICATION / HOCHSTABWEICHUNG DER RECHTWINKLIGKEIT IM VERHÄLTNIS ZU DEN ENTSPRECHENDEN HERSTELLMÄßEN IN PROZENTEN / DESVIACIÓN MÁXIMA DE LA ORTOGONALIDAD, EN TANTO POR CIENTO, EN RELACIÓN CON EL TAMAÑO DE FABRICACIÓN CORRESPONDIENTE		Squadrato ISO 13006		±0,3%	±1,8mm	±0,2%	ISO 10545-2
PLANARITÀ (CURVATURA DEL CENTRO, DELLO SPIGOLO E SVERGOLAMENTO) / FLATNESS (CURVING IN THE MIDDLE, CORNER AND WARRING) / PLANÉTE (COUREURE CENTRALE, DE L'ARÊTE ET GAUCHISSEMENT) / EBENFLÄCHIGKEIT (KRÜMMUNG DER MITTE, DER KANTE UND VERWINDUNG) / PLANITUD (CURVATURA DEL CENTRO, DE LA ARISTA Y ABAQUILLAMIENTO)		Squadrato ISO 13006		±0,4%	±1,8mm	±0,2%	ISO 10545-2
QUALITÀ DELLA SUPERFICIE - SURFACE QUALITY / QUALITÉ DE LA SURFACE - QUALITÄT DER OBERFLÄCHE / CALIDAD DE LA SUPERFICIE		Il 95% min delle piastrelle deve essere esente da difetti visibili. At least 95% of the tiles must be free from visible flaws. 95% min des carreaux ne doivent présenter aucun défaut visible. Mindestens 95% der Fliesen müssen frei von sichtbaren min. El 95% de las baldosas tiene que estar exento de defectos visibles		CONFORME/CONFORMING CONFORME/KONFORM CONFORME			ISO 10545-2
MASSA D'ACQUA ASSORBITA IN % / % WATER ABSORPTION - MASSE D'EAU ABSORBÉE EN % WASSERAUFNAHME IN % MASA DE AGUA ABSORBIDA EN %		< 0,5%		valore medio 0,08%			ISO 10545-3
FORZA DI ROTTURA IN N (sp. ≥ 7,5 mm) - BREAKING STRENGTH IN N (thickness ≥ 7,5 mm) / FORCE DE RUPTURE EN N (ép. ≥ 7,5 mm) / BRUCHLAST IN N (Dicke ≥ 7,5 mm) / FUERZA DE ROTURA EN N (gr. ≥ 7,5 mm)		≥ 700		valore medio 1350 Newton			ISO 10545-4
RESISTENZA ALLA FLESSIONE IN N/mm2 / N/mm2 FLEXURAL STRENGTH TEST / RÉSISTANCE A LA FLEXION EN N/mm2 / BIEGEFESTIGKEIT IN N/mm / RESISTENCIA A LA FLEXIÓN EN N/mm		35 MIN.		valore medio 52 N/mm2			ISO 10545-4
RESISTENZA ALL'ABRASIONE DELLE PIASTRELLE SMALTATE / RESISTANCE TO ABRASION OF GLAZED TILES / RÉSISTANCE À L'ABRASION DES CARREAUX ÉMAILLÉS / TIEFENABRIEBFESTIGKEIT GLASIERTER FLIESEN / RESISTENCIA A LA ABRASIÓN DE LAS BALDOSAS ESMALTADAS		come dichiarato dal produttore see manufacturer's declaration selon déclaration du producteur entsprechend der herstellereangaben tal como declara el fabricante		STATUARIO CLASSE 4 CALACATTA CLASSE 4 MARQUINIA CLASSE 2	CALACATTA ALT. BLANC CLASSE 4 D'NYX BLANC CLASSE 4 BIECHE CARAVAGE CLASSE 4 MARRON IMPÉRIAL CLASSE 2 OMBRE DE CARAVAGE CLASSE 2 LES QUATRE SAISONS CLASSE 2 JOSEPHINE CLASSE 2 SODALITE BLEU CLASSE 2	MATTE D. ARABESQUE CLASSE 3 W. FANTASY CLASSE 4 CH. AMBER CLASSE 2 TH. NIGHT CLASSE 2 GLOSSY D. ARABESQUE CLASSE 2 W. FANTASY CLASSE 4 CH. AMBER CLASSE 2 TH. NIGHT CLASSE 2	ISO 10545-7
RESISTENZA AGLI SBALZI TERMICI / THERMAL SHOCKS RESISTANT / RÉSISTANCE AUX VARIATIONS THERMIQUES TEMPÉRATURWECHSELBESTÄNDIGKEIT / RESISTENCIA AL CHOQUE TÉRMICO		Metodo di prova disponibile/Available testing method Méthode d'essai disponible/Verfügbare Prüfmethode Método de ensayo disponible		RESISTE - RÉSISTANT RESISTE - ERFÜLLT RESISTE			ISO 10545-9
RESISTENZA AL GELO / FROST RESISTANCE - RÉSISTANCE AU GEL / FROSTSICHERHEIT - RESISTENCIA A LA HELADA		richiesta - required requise - gefordert requerida		RESISTE - RÉSISTANT RESISTE - ERFÜLLT RESISTE			ISO 10545-12
RESISTENZA ALLE MACCHIE / RESISTANCE TO STAINING / RÉSISTANCE AUX TACHES / FLECKENABWEISEND RESISTENCIA A LAS MANCHAS		Metodo di prova disponibile Available testing method Méthode d'essai disponible Verfügbare Prüfmethode Método de ensayo disponible		Classe 3-4			ISO 10545-14
RILASCIO DI SOSTANZE PERICOLOSE / RELEASE OF HAZARDOUS SUBSTANCES /REJET DE SUBSTANCES DANGEREUSES / FREISETZUNG GEFÄHRLICHER STOFFE / LIBERACIÓN DE SUSTANCIAS PELIGROSAS CADMIO (in mg/dm ²) - PIOMBO (in mg/dm ²)		valore dichiarato per superfici GL con impieghi su piani di lavoro declared value for GL surfaces used on worktops valeur déclarée pour surfaces GL utilisées sur plans de travail angegebener wert für GL oberflächen zum gebrauch als arbeitsplatten valor declarado para acabados GL utilizados para superficies de trabajo		CONFORME/CONFORMING CONFORME/KONFORM/CONFORME			DM-1-2-2007-Reg-CE-1935-2004
RESISTENZA A BASSE CONCENTRAZIONI DI ACIDI E ALCALI. / RESISTANCE TO LOW CONCENTRATIONS OF ACIDS AND ALKALIS. / RESISTANCE A BASSES CONCENTRATIONS D'ACIDES ET ALCALIS. / WIDERSTAND GEGEN NIEDRIGE KONZENTRATIONEN VON SAUREN UND LAUGEN. / RESISTENCIA A BAJAS CONCENTRACIONES DE ACIDOS Y ALCALIS. /		come dichiarato dal produttore see manufacturer's declaration selon déclaration du producteur entsprechend der herstellereangaben tal como declara el fabricante		GLB			ISO 10545-13
RESISTENZA AI PRODOTTI CHIMICI DI USO DOMESTICO E AGLI ADDITIVI PER PISCINA / RESISTENCE TO DOMESTIC CHEMICAL PRODUCTS AND ADDITIVES FOR SWIMMING POOLS / RÉSISTANT AUX PRODUITS CHIMIQUES À USAGE DOMESTIQUE ET AUX ADDITIFS POUR PISCINE / WIDERSTAND GEGEN HAUSHALTSCHIMIKALIEN UND SCHWIMMBADZUSATZSTOFFEN / RESISTENCIA A PRODUCTOS PARA LIMPIEZA DOMESTICA Y ADITIVOS PARA PISCINAS		MIN B		GA			
RESISTENZA AL CAVILLO DI PIASTRELLE SMALTATE /GLAZE CRAZING RESISTANCE - RÉSISTANCE AU TRESSAILLAGE POUR LES CARREAUX ÉMAILLÉS / WIDERSTAND GEGEN HAARRISS VON GLASIERTEN FLIESEN - RESISTENCIA AL CUARTEADO DE LOS AZULEJOS ESMALTADOS		richiesta - required requise - gefordert requerida		RESISTE - RÉSISTANT RESISTE - ERFÜLLT RESISTE			ISO 10545-11
COEFFICIENTE D'ATTRITO (SCIVOLosità) / FRICTION COEFFICIENT (SLIPPERINESS) / COEFFICIENT DE FRICTION (GLISSEMENT) / REIBUNGSKOEFFIZIENT (SCHLÜPFRIEGKEIT) - COEFICIENTE DE ANTI DESLIZAMIENTO		-		>0,42 wet MATTE	>0,42 wet MARRON IMPÉRIAL OMBRE DE CARAVAGE SODALITE BLEU JASPE ROUGE MATTE	>0,42 wet MATTE	DCOF (section 9.6 ANSI A 137.1.2012)

Per un effetto ottimale della posa, florim suggerisce di mantenere 2 mm di fuga per pose monoformato e 3 mm per combinare formati misti / For optimal installation results, florim recommends maintaining a joint of 2 mm 1/16" for single format installations and 3 mm 1/8" to combine mixed formats / Pour réaliser une pose parfaite, florim suggère de maintenir 2 mm de joint pour la pose des monoformats et 3 mm pour les combinaisons de formats mixtes / Um einen optimalen effekt beim verlegen zu erzielen empfiehlt florim eine 2 mm fugе bei einformatigen verlegungen und 3 mm fugе bei formatkombinationen / Para lograr los máximos resultados en la posa del producto, florim aconseja 2 mm de junta en aplicaciones monoformato y 3 mm en combinaciones de formatos mixtos.

ARDOISE - MATIÈRES - LA ROCHE - HERITAGE LUXE

GRES FINE PORCELLANATO/FINE PORCELAIN STONEWARE/GRES CERAME FIN/FEINSTEINZEUG-KOLLEKTIONEN/GRES PORCELANICO FINO

SQUADRATO - SQUARED - EQUARRI - REKTIFIZIERT - ESCUADRADO

6 mm 1/4" ↑

CARATTERISTICHE TECNICHE - TECHNICAL CHARACTERISTICS - CARACTERISTIQUES TECHNIQUES - TECHNISCHE EIGENSCHAFTEN - CARACTERÍSTICAS TÉCNICAS										
Lastre in gres fine porcellanato non smaltato. Piastrelle di ceramica pressata a secco. Caratteristiche di qualità secondo i test di controllo previsti dalla norma EN 14411-ISO 13006 Appendice G gruppo B1a UGL. / Unglaziert porcelain stoneware slabs. Dry-pressed ceramic tiles. Quality specifications, according to control tests of EN 14411-ISO 13006 Appendix G group B1a UGL. / Dalles en grès cérame fin non émaillé. Carreaux céramiques pressés à sec. Caractéristiques de qualité d'après les essais de contrôle norme EN 14411-ISO 13006 Appendice G groupe B1a UGL. / Nicht glasierte und vollständig gesinterter Feinsteinzeugplatten. Trocken gepresste Keramikfliesen. Qualitätseigenschaften nach Normen EN 14411-ISO 13006 Anhang G Gruppe B1a UGL. / Planchas de gres porcelánico fino no esmaltado. Baldosas de cerámica rensadas en seco. Características de calidad según las Normas EN 14411-ISO 13006 Apéndice G grupo B1a UGL.		PRESCRIZIONE STANDARD REQUIREMENTS PRESCRIPTIONS ANFORDERUNGEN PRESCRIPTION		RISULTATI TESTS TEST RESULTS RESULTATS DES ESSAIS PRÜFERGEBNIS RESULTADOS TESTS				RIFERIMENTO NORMA REFERENCE STANDARD STANDARDWERT REFERENCIA NORMA		
		N ≥ 15 cm		N ≥ 15 cm						
		(%)	(mm)	ARDOISE	LA ROCHE	MATIÈRES	HERITAGE LUXE			
	LUNGHEZZA E LARGHEZZA: DEVIAZIONE AMMISSIBILE, IN % DELLA DIMENSIONE MEDIA DI OGNI PIASTRELLA DALLA DIM. DI FABBRICAZIONE / LENGTH AND WIDTH- ADMITTED DEVIATION, IN % OF THE AVERAGE SIZE OF EACH TILE FROM THE PRODUCTION DIMENSIONS / LONGUEUR ET LARGEUR : MARGE DE TOLERANCE, EN % ENTRE LA DIMENSION MOYENNE DE CHAQUE CARREAU ET LA DIM. DE FABRICATION / LANGE UND BREITE: ZULÄSSIGE ABWEICHUNG DES DURCHSCHNITTMÄßES JEDER FLIESE VOM HERSTELLMAß IN PROZENTEN / LARGO Y ANCHO: DESVIACION ADMISIBLE, EN % DEL TAMAÑO MEDIO DE CADA BALDOSA A PARTIR DEL TAMAÑO DE FABRICACIÓN.	Squadrato ISO 13006	±0,3%	±1,0mm	±0,15%				ISO 10545-2	
	DEVIAZIONE AMMISSIBILE, IN PERCENTO, DELLO SPESORE MEDIO DI OGNI PIASTRELLA DALLA DIMENSIONE DI FABBRICAZIONE / ADMITTED DEVIATION, IN % OF THE AVERAGE THICKNESS OF EACH TILE FROM THE PRODUCTION DIMENSIONS / MARGE DE TOLERANCE, EN POURCENTAGE, ENTRE L'ÉPAISSEUR MOYENNE DE CHAQUE CARREAU ET LA DIMENSION DE FABRICATION / ZULÄSSIGE ABWEICHUNG DER DURCHSCHNITTSDICKE JEDER FLIESE VOM HERSTELLMAß IN PROZENTEN / DESVIACION ADMISIBLE, EN TANTO POR CIENTO, DEL GROSOR MEDIO DE CADA BALDOSA A PARTIR DEL TAMAÑO DE FABRICACIÓN.	-	±5%	±0,5mm	±5%				ISO 10545-2	
	DEVIAZIONE MASSIMA DI RETTILINEARITÀ, IN PERCENTO, IN RAPPORTO ALLE DIMENSIONI DI FABBRICAZIONE CORRESPONDENTI / MAXIMUM STRAIGHTNESS DEVIATION, IN % IN RELATION TO THE CORRESPONDING PRODUCTION DIMENSIONS / MARGE DE TOLERANCE DE RECTITUDE, EN POURCENTAGE, PAR RAPPORT AUX DIMENSIONS DE FABRICATION CORRESPONDANTES / ZULÄSSIGE HOCHSTABWEICHUNG DER KÄNTENGERADHEIT IM VERHÄLTNIß ZU DEN ENTSPRECHENDEN HERSTELLMAßEN IN PROZENTEN / DESVIACION MÁXIMA DE RECTITUD, EN TANTO POR CIENTO, EN RELACION CON EL TAMAÑO DE FABRICACIÓN CORRESPONDIENTE.	Squadrato ISO 13006	±0,3%	±0,8mm	±0,10%				ISO 10545-2	
	DEVIAZIONE MASSIMA DI ORTOGONALITÀ, IN PERCENTO, IN RAPPORTO ALLE DIMENSIONI DI FABBRICAZIONE CORRESPONDENTI MAXIMUM RIGHT-ANGLE DEVIATION, IN % IN RELATION TO THE CORRESPONDING PRODUCTION DIMENSIONS / MARGE DE TOLERANCE D'ANGULARITÉ, EN POURCENTAGE, PAR RAPPORT AUX DIMENSIONS DE FABRICATION / HOCHSTABWEICHUNG DER RECHTWINKELIGKEIT IM VERHÄLTNIß ZU DEN ENTSPRECHENDEN HERSTELLMAßEN IN PROZENTEN / DESVIACION MÁXIMA DE LA ORTOGONALIDAD, EN TANTO POR CIENTO, EN RELACION CON EL TAMAÑO DE FABRICACIÓN CORRESPONDIENTE.	Squadrato ISO 13006	±0,3%	±1,5mm	±0,20%				ISO 10545-2	
	PLANARITÀ (CURVATURA DEL CENTRO, DELLO SPIGOLO E SVERGOLAMENTO) / FLATNESS (CURVING IN THE MIDDLE, CORNER AND WARPING) / PLANÉTÉ (COURBURE CENTRALE, DE L'ÂRETÉ ET GAUCHISSEMENT) / EBENFLÄCHIGKEIT (KRÜMMUNG DER MITTE, DER KANTE UND VERWINDUNG) / PLANITUD (CURVATURA DEL CENTRO, DE LA ARISTA Y ABARQUILLAMIENTO).	Squadrato ISO 13006	±0,4%	±1,8mm	±0,20%				ISO 10545-2	
	QUALITÀ DELLA SUPERFICIE / SURFACE QUALITY / QUALITÉ DE LA SURFACE / QUALITÄT DER OBERFLÄCHE / CALIDAD DE LA SUPERFICIE.	Il 95% min delle piastrelle deve essere esente da difetti visibili. / At least 95% of the tiles must be free from visible flaws. 95% min des carreaux ne doivent présenter aucun défaut visible. Mindestens 95% der Fliesen müssen frei von sichtbaren min. / el 95% de las baldosas que estar exento de defectos visibles.				CONFORME/CONFORMING CONFORME/KONFORM CONFORME				ISO 10545-2
	MASSA D'ACQUA ASSORBITA IN % / % WATER ABSORPTION - MASSE D'EAU ABSORBÉE EN % / WASSERAUFNAHME IN % / MASA DE AGUA ABSORBIDA EN %	< 0,5%				valore medio 0,08%				ISO 10545-3
	FORZA DI ROTTURA IN N (sp. < 7,5 mm) / BREAKING STRENGTH IN N (thickness < 7,5 mm) / FORCE DE RUPTURE EN N (é. < 7,5 mm) / BRUCHLAST IN N (Dicke < 7,5 mm) / FUERZA DE ROTURA EN N (gr. < 7,5 mm).	≥ 700				valore medio 1350 Newton				ISO 10545-4
	RESISTENZA ALLA FLESSIONE IN N/mm2 / N/mm2 FLEXURAL STRENGTH TEST / RESISTANCE A LA FLEXION EN N/mm2 / BIEGESTÄRKE IN N/mm2	35 MIN.				valore medio 52 N/mm2				ISO 10545-4
	RESISTENZA ALL'ABRAZIONE PROFONDA DELLE PIASTRELLE NON SMALTATE / RESISTANCE TO DEEP ABRASION OF UNGLAZED TILES / RESISTANCE A L'ABRASION PROFONDE DES CARREAUX NON ÉMAILLÉS / TIEFENABRIEBESTÄNDIGKEIT UNGLASIRTER FLIESEN / RESISTENCIA A LA ABRASION PROFUNDA DE LAS BALDOSAS SIN ESMALTAR.	< 175 mm ³				valore medio 140 mm ³				ISO 10545-6
	RESISTENZA AGLI SBALZI TERMICI / THERMAL SHOCKS RESISTANT / RESISTANCE AUX VARIATIONS THERMIQUES / TEMPERATURWECHSELBESTÄNDIGKEIT / RESISTENCIA AL CHOQUE TÉRMICO.	Metodo di prova disponibile / Available testing method Méthode d'essai disponible / Vertugbare Prüfmethode Método de ensayo disponible				RESISTE - RESISTANT RESISTE - ERFÜLLT RESISTE				ISO 10545-9
	RESISTENZA AL GELO / FROST RESISTANCE / RESISTANCE AU GEL / FROSTSICHERHEIT / RESISTENCIA A LA HELADA	RICHIESTA - REQUIRED REQUISE - GEFORDERT REQUERIDA				RESISTE - RESISTANT RESISTE - ERFÜLLT RESISTE				ISO 10545-12
	RESISTENZA ALLE MACCHIE / RESISTANCE TO STAINING / RESISTANCE AUX TACHES / FLECKENABWEISEND / RESISTENCIA A LAS MANCHAS.	Metodo di prova disponibile / Available testing method Méthode d'essai disponible / Vertugbare Prüfmethode Método de ensayo disponible				Classe 4	Classe 3-4	Classe 4-5	Classe 5 COMFORT Classe 4-5 GLOSSY	ISO 10545-14
	RILASCIO DI SOSTANZE PERICOLOSE / RELEASE OF HAZARDOUS SUBSTANCES / REJET DE SUBSTANCES DANGEREUSES / FREISETZUNG GEFAHRLICHER STOFFE / LIBERACION DE SUSTANCIAS PELIGROSAS / CADMIO (in mg/dm ²) - PIOMBO (in mg/dm ²)	VALORE DICHIARATO PER SUPERFICIE GL CON IMPIEGHI SU PIANI DI LAVORO / DECLARED VALUE FOR GL SURFACES USED ON WORKTOPS / VALEUR DÉCLARÉE POUR SURFACES GL UTILISÉES SUR PLANS DE TRAVAIL / ANGEBORENEN WERT FÜR GL OBERFLÄCHEN ZUM GEBRAUCH ALS ARBEITSTÄTTEN / VALOR DICLARADO PARA ACABADOS GL UTILIZADOS PARA SUPERFICIES DE TRABAJO				CONFORME/CONFORMING CONFORME/KONFORM/CONFORME				DM-1-2-2007-Reg-CE-1935-2004
	RESISTENZA A BASSE CONCENTRAZIONI DI ACIDI E ALCALI. / RESISTANCE TO LOW CONCENTRATIONS OF ACIDS AND ALKALIS. / RESISTANCE A BASSES CONCENTRATIONS D'ACIDES ET ALCALIS. / WIDERSTAND GEGEN NIEDRIGE KONZENTRATIONEN VON SAUREN UND LAUGEN. / RESISTENCIA A BAJAS CONCENTRACIONES DE ACIDOS Y ALCALIS.	COME DICHIARATO DAL PRODUTTORE SEE MANUFACTURER'S DECLARATION SELON DÉCLARATION DU PRODUCTEUR ENTSPRECHEND DER HERSTELLERANGABEN TAL COMO DECLARA EL FABRICANTE				ULA	ULB	ULA	ULA COMFORT ULA-ULB GLOSSY	ISO 10545-13
	RESISTENZA A ALTE CONCENTRAZIONI DI ACIDI ED ALCALI / RESISTANCE TO HIGH CONCENTRATIONS OF ACIDS AND ALKALIS / RESISTANCE A HAUTES CONCENTRATIONS D'ACIDES ET BASES / BESTÄNDIGKEIT GEGEN STARK KONZENTRIERTE SAUREN UND LAUGEN / RESISTENCIA A ALTAS CONCENTRACIONES DE ACIDOS Y ALCALIS.					UHA	UHB	-	-	
	RESISTENZA AI PRODOTTI CHIMICI DI USO DOMESTICO E AGLI ADDITIVI PER PISCINA / RESISTENCE TO DOMESTIC CHEMICAL PRODUCTS AND ADDITIVES FOR SWIMMING POOLS / RESISTANT AUX PRODUITS CHIMIQUES À USAGE DOMESTIQUE ET AUX ADDITIFS POUR PISCINE / WIDERSTAND GEGEN HAUSHALTSCHEMIKALIEN UND / SCHWIMMBADZUSATZSTOFFEN / RESISTENCIA A PRODUCTOS PARA LIMPIEZA DOMESTICA Y ADITIVOS PARA PISCINAS	MIN B				UA				
	COEFFICIENTE D'ATTRITO (SCIVOLOSITÀ) / FRICTION COEFFICIENT (SLIPPERINESS) / COEFFICIENT DE FRICTION (GLISSEMENT) / REIBUNGSKOEFFIZIENT (SCHLUPFRIGKEIT) / COEFFICIENTE DE ANTI DESLIZAMIENTO.	6° ≤ α < 10° R9		-	6° ≤ α < 10° R9	-	6° ≤ α < 10° R9 MATTE	10° ≤ α < 19° R10 COMFORT	DIN EN 16165 ANNEX B	
		10° ≤ α < 19° R10 R+PTV		-	-	12° ≤ α < 18° classe A MATTE	-	18° ≤ α < 24° classe B COMFORT	DIN EN 16165 ANNEX A	
		18° ≤ α < 24° classe B R+PTV		-	-	-	-	PTV>36 wet slider 45 R+PTV	PTV>36 wet slider 45 COMFORT	BS EN 16165 ANNEX C
		> 0,42 wet		> 0,42 wet	> 0,42 wet	> 0,42 wet	> 0,42 wet	> 0,42 wet	> 0,42 wet	ANSI A 326.3

Per un effetto ottimale della posa, florim suggerisce di mantenere 2 mm di fuga per pose monoformato e 3 mm per combinare formati misti / For optimal installation results, florim recommends maintaining a joint of 2 mm 1/16" for single format installations and 3 mm 1/8" to combine mixed formats / Pour réaliser une pose parfaite, florim suggère de maintenir 2 mm de joint pour la pose des monoformats, et 3 mm pour les combinaisons de formats mixtes / Um einen optimalen effekt beim verlegen zu erzielen empfiehlt florim eine 2 mm fuge bei einformatigen verlegungen und 3 mm fuge bei formatkombinationen / Para lograr los máximos resultados en la posa del producto, florim aconseja 2 mm de junta en aplicaciones monoformato y 3 mm en combinaciones de formatos mixtos.

I FILATI

GRES PORCELLANATO DECORATO
 DECORATED PORCELAIN TILES - GRÈS CÉRAMÉ DÉCORÉ - VERZIERTES FEINSTEINZEUG - GRES PORCELÁNICO DECORADO
 SQUADRATO - SQUARED - EQUARRI - REKTIFIZIERT - ESCUADRADO



CARATTERISTICHE TECNICHE - TECHNICAL CHARACTERISTICS - CARACTERISTIQUES TECHNIQUES - TECHNISCHE EIGENSCHAFTEN - CARACTERÍSTICAS TÉCNICAS						
	Caratteristiche di qualità secondo i tests di controllo previsti dalle norme EN 14411- ISO 13006 appendice G gruppo Bia Superficie Trattata / Quality characteristics according to the inspection tests envisaged by standard EN 14411- ISO 13006 appendix G group Bia Surface treatment / Caractéristiques de qualité selon les tests de contrôle prévus par les normes EN 14411- ISO 13006 appendice G groupe Bia Surface traitée / Qualitätseigenschaften gemäß den Kontrolltests der Normen EN 14411- ISO 13006, Anhang G Gruppe Bia behandelte Oberfläche / Características de calidad según los ensayos previstos por las normas EN 14411- ISO 13006 apéndice G grupo Bia Superficie tratada.	PRESCRIZIONE STANDARD REQUIREMENTS ANFORDERUNGEN PRESCRIPCION		RISULTATI TESTS TEST RESULTS RESULTATS DES ESSAIS PRÜFERGEBNIS RESULTADOS TESTS	RIFERIMENTO NORMA REFERENCE STANDARD RÉFÉRENCE NORME STANDARDWERT REFERENCIA NORMA	
		N ≥ 15 cm				
		(%)	(mm)			
	LUNGHEZZA E LARGHEZZA: DEVIAZIONE AMMISSIBILE, IN %, DELLA DIMENSIONE MEDIA DI OGNI PIASTRELLA DALLA DIM. DI FABBRICAZIONE / LENGTH AND WIDTH: ADMITTED DEVIATION, IN %, OF THE AVERAGE SIZE OF EACH TILE FROM THE PRODUCTION DIMENSIONS / LONGUEUR ET LARGEUR: MARGE DE TOLÉRANCE EN %, ENTRE LA DIMENSION MOYENNE DE CHAQUE CARREAU ET LA DIM. DE FABRICATION / LANGE UND BREITE: ZULÄSSIGE ABWEICHUNG DES DURCHSCHNITTMÄßES JEDER FLIESE VOM HERSTELLMAß IN PROZENTEN / LARGO Y ANCHO: DESVIACIÓN ADMISIBLE, EN %, DEL TAMAÑO MEDIO DE CADA BALDOSA A PARTIR DEL TAMAÑO DE FABRICACION .	Squadrato ISO 13006	±0,3%	±1,0 mm	±0,15%	ISO 10545-2
	DEVIAZIONE AMMISSIBILE, IN PERCENTO, DELLO SPESSORE MEDIO DI OGNI PIASTRELLA DALLA DIMENSIONE DI FABBRICAZIONE / ADMITTED DEVIATION, IN %, OF THE AVERAGE THICKNESS OF EACH TILE FROM THE PRODUCTION DIMENSIONS / MARGE DE TOLÉRANCE, EN POURCENTAGE, ENTRE L'ÉPAISSEUR MOYENNE DE CHAQUE CARREAU ET LA DIMENSION DE FABRICATION / ZULÄSSIGE ABWEICHUNG DER DURCHSCHNITTSDICKE JEDER FLIESE VOM HERSTELLMAß IN PROZENTEN / DESVIACIÓN ADMISIBLE, EN TANTO POR CIENTO, DEL GROSOR MEDIO DE CADA BALDOSA A PARTIR DEL TAMAÑO DE FABRICACION	-	±5%	±0,5 mm	±5%	ISO 10545-2
	DEVIAZIONE MASSIMA DI RETTILINEARITÀ, IN PERCENTO, IN RAPPORTO ALLE DIMENSIONI DI FABBRICAZIONE CORRISPONDENTI / MAXIMUM STRAIGHTNESS DEVIATION, IN %, IN RELATION TO THE CORRESPONDING PRODUCTION DIMENSIONS / MARGE DE TOLÉRANCE DE RECTITUDE, EN POURCENTAGE, PAR RAPPORT AUX DIMENSIONS DE FABRICATION CORRESPONDANTES / ZULÄSSIGE HOCHSTABWEICHUNG DER KANTENGERADHEIT IM VERHÄLTNIS ZU DEN ENTSPRECHENDEN HERSTELLMAßEN IN PROZENTEN / DESVIACIÓN MÁXIMA DE RECTITUD, EN TANTO POR CIENTO, EN RELACION CON EL TAMAÑO DE FABRICACION CORRESPONDIENTE	Squadrato ISO 13006	±0,3%	±0,8 mm	±0,1%	ISO 10545-2
	DEVIAZIONE MASSIMA DI ORTOGONALITÀ, IN PERCENTO, IN RAPPORTO ALLE DIMENSIONI DI FABBRICAZIONE CORRISPONDENTI / MAXIMUM RIGHT-ANGLE DEVIATION, IN %, IN RELATION TO THE CORRESPONDING PRODUCTION DIMENSIONS / MARGE DE TOLÉRANCE D'ANGULARITÉ, EN POURCENTAGE, PAR RAPPORT AUX DIMENSIONS DE FABRICATION / HOCHSTABWEICHUNG DER RECHTWINKLIGKEIT IM VERHÄLTNIS ZU DEN ENTSPRECHENDEN HERSTELLMAßEN IN PROZENTEN / DESVIACIÓN MÁXIMA DE LA ORTOGONALIDAD, EN TANTO POR CIENTO, EN RELACION CON EL TAMAÑO DE FABRICACION CORRESPONDIENTE	Squadrato ISO 13006	±0,3%	±1,5 mm	±0,2%	ISO 10545-2
	PLANARITÀ (CURVATURA DEL CENTRO, DELLO SPIGOLO E SVERGOLAMENTO) / FLATNESS (CURVING IN THE MIDDLE, CORN AND WARRING) / PLANÉITÉ (COURBURE DIMENSIONNELLE DE L'ARÊTE ET GAUCHISSEMENT) / EBENFLÄCHIGKEIT (KRÜMMUNG DER MITTE, DER KANTE UND VERWINDUNG) / PLANITUD (CURVATURA DEL CENTRO, DE LA ARISTA Y ABARQUILLAMIENTO)	Squadrato ISO 13006	±0,4%	±1,8 mm	±0,2%	ISO 10545-2
	QUALITÀ DELLA SUPERFICIE / SURFACE QUALITY / QUALITÉ DE LA SURFACE QUALITÄT DER OBERFLÄCHE / CALIDAD DE LA SUPERFICIE	Il 95% min delle piastrelle deve essere esente da difetti visibili. At least 95% of the tiles must be free from visible flaws. 95% min des carreaux ne doivent présenter aucun défaut visible. Mindestens 95% der Fliesen müssen frei von sichtbaren min. El 95% de las baldosas tiene que estar exento de defectos visibles		CONFORME CONFORMING CONFORME KONFORM CONFORME	ISO 10545-2	
	MASSA D'ACQUA ASSORBITA IN % / % WATER ABSORPTION / MASSE D'EAU ABSORBÉE EN % / WASSERAUFNAHME IN % / MASA DE AGUA ABSORBIDA EN %		< 0,5%		valore medio 0,08%	ISO 10545-3
	FORZA DI ROTTURA IN N (sp. < 7,5 mm) - BREAKING STRENGTH IN N (thickness < 7,5 mm) / FORCE DE RUPTURE EN N (sp. < 7,5 mm) / BRUCHLAST IN N (Dicke < 7,5 mm) / FUERZA DE ROTURA EN N (gr. < 7,5 mm)		≥ 700		valore medio 1350 N	ISO 10545-4
	RESISTENZA ALLA FLESSIONE IN N/mm2 / N/mm2 FLEXURAL STRENGTH TEST RESISTANCE A LA FLEXION EN N/mm2 / BIEGEFESTIGKEIT IN N/mm2 RESISTENCIA A LA FLEXION EN N/mm2		35 MIN.		valore medio 52 N/mm2	ISO 10545-4
	RESISTENZA ALLE MACCHIE / RESISTANCE TO STAINING / RÉSISTANCE AUX TACHES / FLECKENABWEISEND / RESISTENCIA A LAS MANCHAS				Classe 3-4	ISO 10545-14
	RESISTENZA AI PRODOTTI CHIMICI DI USO DOMESTICO E AGLI ADDITIVI PER PISCINA / RESISTENCE TO DOMESTIC CHEMICAL PRODUCTS AND ADDITIVES FOR SWIMMING POOLS / RESISTANT AUX PRODUITS CHIMIQUES A USAGE DOMESTIQUE ET AUX ADITIFS POUR PISCINE / WIDERSTAND GEGEN HAUSHALTSCHIMIKALIEN UND / SCHWIMMBADZUSATZSTOFFEN / RESISTENCIA A PRODUCTOS PARA LIMPIEZA DOMESTICA Y ADITIVOS PARA PISCINAS		MIN B		B	ISO 10545-13
	REAZIONE AL FUOCO / FIRE - RESISTANCE / RÉACTION AU FEU / VERHALTEN IM BRANDFALL REACCIÓN AL FUEGO		-		Classe B	UNI EN 13501:1 2009

Lastre decorate destinate esclusivamente al rivestimento di pareti interne. / Decorated panels designed exclusively for tiling interior walls. / Dalles décorées, exclusivement destinées au revêtement de parois intérieures. / Verzerrte Platten, ausschließlich zur Verkleidung von Innenwänden bestimmt. / Losas decoradas destinadas exclusivamente al revestimiento de paredes interiores.



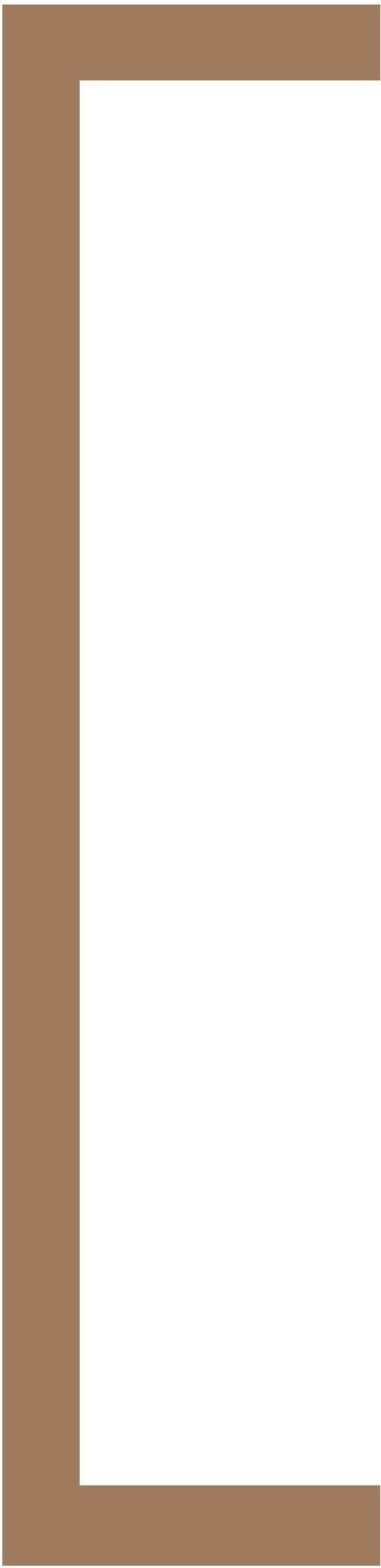





Gres porcellanato decorato: florim indica di stoccare il materiale in magazzini coperti o al riparo da agenti atmosferici / Florim recommends to stock the goods in covered warehouses, do not expose to the elements Florim conseille de stocker le matériel dans des entrepôts couverts ou à l'abri des agents atmosphériques / Florim empfiehlt, das Material in geschlossenen Lagern oder in vor Witterungseinflüssen geschützten Bereichen zu lagern. / Florim indica almacenar el material en locales cubiertos o protegido de los agentes atmosféricos.



CARATTERISTICHE TECNICHE













TECHNICAL FEATURES
CARACTÉRISTIQUES TECHNIQUES
TECHNISCHE EIGENSCHAFTEN
CARACTERISTICAS TÉCNICAS

9mm

CARATTERISTICHE TECNICHE - TECHNICAL CHARACTERISTICS - CARACTERISTIQUES TECHNIQUES - TECHNISCHE EIGENSCHAFTEN - CARACTERÍSTICAS TÉCNICAS						
	Lastre in gres fine porcellanato non smaltato. Piastrelle di ceramica pressate a secco. Caratteristiche di qualità secondo i test di controllo previsti dalla norma EN 14411-ISO 13006 Appendice G gruppo Bia UGL/ Unglazed porcelain stoneware slabs. Dry-pressed ceramic tiles. Quality specifications, according to control tests of EN 14411-ISO 13006 Appendix G group Bia UGL. / Dalles en gres cérame fin non émaillé. Carreaux céramiques pressés à sec. Caractéristiques de qualité d'après les essais de contrôle norme EN 14411-ISO 13006 Appendice G groupe Bia UGL/ Nicht glasierte und vollständig gesinterte Feinsteinzeugplatten. Trocken gepresste Keramikfliesen. Qualitätseigenschaften nach Normen EN 14411-ISO 13006 Anhang G Gruppe Bia UGL/ Planchas de gres porcelánico fino no esmaltado. Baldosas de cerámica resadas en seco. Características de calidad según las Normas EN 14411-ISO 13006 Apéndice G grupo Bia UGL.	PRESCRIZIONE STANDARD REQUIREMENTS PRESCRIPTIONS ANFORDERUNGEN PRESCRIPCION		RISULTATI TESTS TEST RESULTS PRÜFERGEBNIS RESULTADOS TESTS	RIFERIMENTO NORMA REFERENCE STANDARD STANDARDWERT REFERENCIA NORMA	
		N > 15 cm				
		(%)	(mm)			
LUNGHEZZA E LARGHEZZA: DEVIAZIONE AMMISSIBILE, IN %, DELLA DIMENSIONE MEDIA DI OGNI PIASTRELLA DALLA DIM. DI FABBRICAZIONE / LENGTH AND WIDTH: ADMITTED DEVIATION, IN %, OF THE AVERAGE SIZE OF EACH TILE FROM THE PRODUCTION DIMENSIONS / LONGUEUR ET LARGEUR : MARGE DE TOLÉRANCE, EN %, ENTRE LA DIMENSION MOYENNE DE CHAQUE CARREAU ET LA DIM. DE FABRICATION / LÄNGE UND BREITE: ZULÄSSIGE ABWEICHUNG DES DURCHSCHNITTMÄßES JEDER FLIESE VOM HERSTELLMAß IN PROZENTEN / LARGO Y ANCHO: DESVIACION ADMISIBLE, EN %, DEL TAMAÑO MEDIO DE CADA BALDOSA A PARTIR DEL TAMAÑO DE FABRICACIÓN.	Non squadrato EN 14411 - ISO 13006	±0,6%	±2,0mm	±0,6%	ISO 10545-2	
	Squadrato ISO 13006	±0,3%	±1,0mm	±0,15%		
DEVIAZIONE AMMISSIBILE, IN PERCENTO, DELLO SPESORE MEDIO DI OGNI PIASTRELLA DALLA DIMENSIONE DI FABBRICAZIONE / ADMITTED DEVIATION, IN %, OF THE AVERAGE THICKNESS OF EACH TILE FROM THE PRODUCTION DIMENSIONS / MARGE DE TOLÉRANCE, EN POURCENTAGE, ENTRE L'ÉPAISSEUR MOYENNE DE CHAQUE CARREAU ET LA DIMENSION DE FABRICATION / ZULÄSSIGE ABWEICHUNG DER DURCHSCHNITTSDICKE JEDER FLIESE VOM HERSTELLMAß IN PROZENTEN / DESVIACION ADMISIBLE, EN TANTO POR CIENTO, DEL GROSOR MEDIO DE CADA BALDOSA A PARTIR DEL TAMAÑO DE FABRICACIÓN.	-	±5%	±0,5mm	±5%		
DEVIAZIONE MASSIMA DI RETTILINEARITÀ IN PERCENTO, IN RAPPORTO ALLE DIMENSIONI DI FABBRICAZIONE CORRISPONDENTI / MAXIMUM STRAIGHTNESS DEVIATION, IN %, IN RELATION TO THE CORRESPONDING PRODUCTION DIMENSIONS / MARGE DE TOLÉRANCE D'ANGULARITÉ, EN POURCENTAGE, PAR RAPPORT AUX DIMENSIONS DE FABRICATION CORRESPONDANTES / ZULÄSSIGE HOCHSTABWEICHUNG DER RECHTWINKLIGKEIT IM VERHÄLTNIß ZU DEN ENTSPRECHENDEN HERSTELLMAßEN IN PROZENTEN / DESVIACION MÁXIMA DE RECTITUD, EN TANTO POR CIENTO, EN RELACION CON EL TAMAÑO DE FABRICACIÓN CORRESPONDIENTE.	Non squadrato EN 14411 - ISO 13006	±0,5%	±1,5mm	±0,5%		
	Squadrato ISO 13006	±0,3%	±0,8mm	±0,10%		
DEVIAZIONE MASSIMA DI ORTOGONALITÀ IN PERCENTO, IN RAPPORTO ALLE DIMENSIONI DI FABBRICAZIONE CORRISPONDENTI / MAXIMUM RIGHT-ANGLE DEVIATION, IN %, IN RELATION TO THE CORRESPONDING PRODUCTION DIMENSIONS / MARGE DE TOLÉRANCE D'ANGULARITÉ, EN POURCENTAGE, PAR RAPPORT AUX DIMENSIONS DE FABRICATION / HOCHSTABWEICHUNG DER RECHTWINKLIGKEIT IM VERHÄLTNIß ZU DEN ENTSPRECHENDEN HERSTELLMAßEN IN PROZENTEN / DESVIACION MÁXIMA DE LA ORTOGONALIDAD, EN TANTO POR CIENTO, EN RELACION CON EL TAMAÑO DE FABRICACIÓN CORRESPONDIENTE.	Non squadrato EN 14411 - ISO 13006	±0,5%	±2,0mm	±0,5%		
	Squadrato ISO 13006	±0,3%	±1,5mm	±0,20%		
PLANARITÀ (CURVATURA DEL CENTRO, DELLO SPIGOLO E SVERGOLAMENTO) / FLATNESS (CURVING IN THE MIDDLE, CORNER AND WARPING) / PLANÉITÉ (COURBURE CENTRALE, DE L'ARÊTE ET GAUCHISSEMENT) / EBENFLÄCHIGKEIT (KRÜMMUNG DER MITTE, DER KANTE UND VERWINDUNG) / PLANITUD (CURVATURA DEL CENTRO, DE LA ARISTA Y ABARQUILLAMIENTO).	Non squadrato EN 14411 - ISO 13006	±0,5%	±2,0mm	±0,35%		
	Squadrato ISO 13006	±0,4%	±1,8 mm	±0,35%		
QUALITÀ DELLA SUPERFICIE - SURFACE QUALITY / QUALITÉ DE LA SURFACE - QUALITÄT DER OBERFLÄCHE / CALIDAD DE LA SUPERFICIE.	Il 95% min delle piastrelle deve essere esente da difetti visibili. / At least 95% of the tiles must be free from visible flaws. 95% min des carreaux ne doivent présenter aucun défaut visible. Mindestens 95% der Fliesen müssen frei von sichtbaren min. / el 95% de las baldosas tiene que estar exento de defectos visibles.		CONFORME/CONFORMING CONFORME/KONFORM CONFORME.			
 MASSA D'ACQUA ASSORBITA IN % / % WATER ABSORPTION - MASSE D'EAU ABSORBÉE EN % / WASSERAUFNAHME IN % / MASA DE AGUA ABSORBIDA EN %	E≤0,5%		valore medio 0,08%			ISO 10545-3
 FORZA DI ROTTURA IN N (sp. ≥ 7,5 mm) - BREAKING STRENGTH IN N (thickness ≥ 7,5 mm) / FORCE DE RUPTURE EN N (ép. ≥ 7,5 mm) / BRUCHLAST IN N (Dicke ≥ 7,5 mm) / FUERZA DE ROTURA EN N (gr. ≥ 7,5 mm)	1300 min		valore medio 2200 N (spes.9mm) valore medio 14000 N (spes.20mm)			ISO 10545-4
 RESISTENZA ALLA FLESSIONE IN N/mm2 / N/mm2 FLEXURAL STRENGTH TEST / RÉSISTANCE A LA FLEXION EN N/mm2 / BIEGESTÄRKE IN N/mm / RESISTENCIA A LA FLEXION EN N/mm	35 min		valore medio 50 N/mm ² (spes.9mm) valore medio 52 N/mm ² (spes.20mm)		ISO 10545-4	
 RESISTENZA ALL'ABRASIONE PROFONDA DELLE PIASTRELLE NON SMALTATE / RESISTANCE TO DEEP ABRASION OF UNGLAZED TILES / RÉSISTANCE À L'ABRASION PROFONDE DES CARREAUX NON ÉMAILLÉS / TIEFENABRIEFESTIGKEIT UNGLASIRTER FLIESEN / RESISTENCIA A LA ABRASION PROFUNDA DE LAS BALDOSAS SIN ESMALTADO	<175mm ³		valore medio 140mm ³		ISO 10545-6	
 RESISTENZA AGLI SBALZI TERMICI / THERMAL SHOCKS RESISTANT / RÉSISTANCE AUX VARIATIONS THERMIQUES TEMPÉRATURWECHSELBESTÄNDIGKEIT / RESISTENCIA AL CHOQUE TÉRMICO.	-		RESISTE - RÉSTANT RÉSISTE - ERFÜLLT RESISTE		ISO 10545-9	
 RESISTENZA ALLE MACCHIE / RESISTANCE TO STAINING / RÉSISTANCE AUX TACHES / FLECKENABWEISEND RESISTENCIA A LAS MANCHAS	-		≥ Classe 3		ISO 10545-14	
 RESISTENZA A BASSE CONCENTRAZIONI DI ACIDI E ALCALI. / RESISTANCE TO LOW CONCENTRATIONS OF ACIDS AND ALKALIS. / RESISTANCE A BASSES CONCENTRATIONS D'ACIDES ET ALCALIS. / WIDERSTAND GEGEN NIEDRIGE KONZENTRATIONEN VON SAUREN UND LAUGEN. / RESISTENCIA A BAJAS CONCENTRACIONES DE ACIDOS Y ALCALIS.	COME DICHIARATO DAL PRODUTTORE SEE MANUFACTURER'S DECLARATION SELON DÉCLARATION DU PRODUCTEUR ENTSPRECHEND DER HERSTELLERANGABEN TAL COMO DECLARA EL FABRICANTE		vedere la serie - see the collection voir la collection - siehe der kollektion ver la coleccion		ISO 10545-13	
	RESISTENZA A ALTE CONCENTRAZIONI DI ACIDI ED ALCALI / RESISTANCE TO HIGH CONCENTRATIONS OF ACIDS AND ALKALIS / RESISTANCE À DE HAUTES CONCENTRATIONS D'ACIDES ET BASES / BESTÄNDIGKEIT GEGEN STARK KONZENTRIERTE SAUREN UND LAUGEN / RESISTENCIA A ALTAS CONCENTRACIONES DE ACIDOS Y ALCALIS		vedere la serie - see the collection voir la collection - siehe der kollektion ver la coleccion			
	RESISTENZA AI PRODOTTI CHIMICI DI USO DOMESTICO E AGLI ADDITIVI PER PISCINA / RESISTENCE TO DOMESTIC CHEMICAL PRODUCTS AND ADDITIVES FOR SWIMMING POOLS / RÉSISTANT AUX PRODUITS CHIMIQUES À USAGE DOMESTIQUE ET AUX ADDITIFS POUR PISCINE / WIDERSTAND GEGEN HAUSHALTS-CHEMIKALIEN UND SCHWIMMBAZUSATZSTOFFEN / RESISTENCIA A PRODUCTOS PARA LIMPIEZA DOMESTICA Y ADITIVOS PARA PISCINAS		UB min			UA
 RESISTENZA AL GELO / FROST RESISTANCE - RÉSISTANCE AU GEL / FROSTSICHERHEIT - RESISTENCIA A LA HELADA	RICHIESTA / REQUIRED REQUISE / GEFORDET REQUERIDA		RESISTE - RÉSTANT RÉSISTE - ERFÜLLT RESISTE		ISO 10545-12	
 COEFFICIENTE D'ATTRITO (SCIVOLosità) / FRICTION COEFFICIENT (SLIPPERINESS) / COEFFICIENT DE FRICTION (GLUSSEMENT) / REIBUNGSKOEFFIZIENT (SCHLÜPFRIGKEIT) - COEFICIENTE DE ANTI DESLIZAMIENTO	-		vedere la serie - see the collection voir la collection - siehe der kollektion ver la coleccion		-	









Per un effetto ottimale della posa, florim suggerisce di mantenere 2 mm di fuga per pose monoformato e 3 mm per combinare formati misti / For optimal installation results, florim recommends maintaining a joint of 2 mm 1/12" for single format installations and 3 mm 1/8" to combine mixed formats / Pour réaliser une pose parfaite, florim suggère de maintenir 2 mm de joint pour la pose des monoformats, et 3 mm pour les combinaisons de formats mixtes / Um einen optimalen effekt beim verlegen zu erzielen empfehlt florim eine 2 mm fuge bei einformatigen verlegungen und 3 mm fuge bei formatkombinationen / Para lograr los máximos resultados en la posa del producto, florim aconseja 2 mm de junta en aplicaciones monoformato y 3 mm en combinaciones de formatos mixtos.

Per informazioni relative ai dati tecnici su marcatura CE vedere il sito www.florim.com / Please refer to our web site www.florim.com for technical information related to CE labeling / Pour tout renseignement sur l'avis technique de la marque CE veuillez consulter le site www.florim.com / Informationen bezüglich technischer Daten zur Beschriftung CE entnehmen Sie unserer Website www.florim.com / Para obtener más información y descargar las marcas CE: www.florim.com

CARATTERISTICHE TECNICHE - TECHNICAL CHARACTERISTICS - CARACTERISTIQUES TECHNIQUES - TECHNISCHE EIGENSCHAFTEN - CARACTERÍSTICAS TÉCNICAS						
	PIASTRELLE DI CERAMICA PRESSETE A SECCO. Caratteristiche di qualità secondo i test di controllo previsti dalla norma EN 14411-ISO 13006 Appendice G gruppo Bia GL / Dry-pressed ceramic tiles. Quality specifications, according to control tests of EN 14411-ISO 13006 Appendix G group Bia GL. / Carreaux céramiques pressés à sec. Caractéristiques de qualité d'après les essais de contrôle norme EN 14411-ISO 13006 Appendice G groupe Bia GL. / Trocken gepresste Keramikfliesen. / Qualitätsseigenschaften nach Normen EN 14411-ISO 13006 Anhang G Gruppe Bia GL. / Baldosas de cerámica prensadas en seco. Características de calidad según las Normas EN 14411-ISO 13006 Apéndice G grupo Bia GL.	PRESCRIZIONE STANDARD REQUIREMENTS PRESCRIPTIONS ANFORDERUNGEN PRESCRIPCION		RISULTATI TESTS TEST RESULTS RESULTATS DES ESSAIS PRÜFERGEBNIS RESULTADOS TESTS	RIFERIMENTO NORMA REFERENCE STANDARD RÉFÉRENCE NORME STANDARDWERT REFERENCIA NORMA	
		N > 15 cm				
		(%)	(mm)			
	LUNGHEZZA E LARGHEZZA: DEVIAZIONE AMMISSIBILE, IN % DELLA DIMENSIONE MEDIA DI OGNI PIASTRELLA DALLA DIM. DI FABBRICAZIONE / LENGTH AND WIDTH: ADMITTED DEVIATION, IN % OF THE AVERAGE SIZE OF EACH TILE FROM THE PRODUCTION DIMENSIONS / LONGUEUR ET LARGEUR : MARGE DE TOLÉRANCE, EN %, ENTRE LA DIMENSION MOYENNE DE CHAQUE CARREAU ET LA DIM. DE FABRICATION / LANGE UND BREITE: ZULÄSSIGE ABWEICHUNG DES DURCHSCHNITTMÄßES JEDER FLIESE VOM HERSTELLMÄß IN PROZENTEN / LARGO Y ANCHO: DESVIACIÓN ADMISIBLE, EN %, DEL TAMAÑO MEDIO DE CADA BALDOSA A PARTIR DEL TAMAÑO DE FABRICACIÓN /	Non squadrato EN 14411 - ISO 13006	±0,6%	±2,0mm	±0,6%	
	Squadrato ISO 13006	±0,3%	±1,0mm	±0,15%		
	DEVIAZIONE AMMISSIBILE, IN PERCENTO, DELLO SPESSORE MEDIO DI OGNI PIASTRELLA DALLA DIMENSIONE DI FABBRICAZIONE / ADMITTED DEVIATION, IN % OF THE AVERAGE THICKNESS OF EACH TILE FROM THE PRODUCTION DIMENSIONS / MARGE DE TOLÉRANCE, EN POURCENTAGE, ENTRE L'ÉPAISSEUR MOYENNE DE CHAQUE CARREAU ET LA DIMENSION DE FABRICATION / ZULÄSSIGE ABWEICHUNG DER DURCHSCHNITTSDICKE JEDER FLIESE VOM HERSTELLMÄß IN PROZENTEN / DESVIACIÓN ADMISIBLE, EN TANTO POR CIENTO, DEL GROSOR MEDIO DE CADA BALDOSA A PARTIR DEL TAMAÑO DE FABRICACIÓN	-	±5%	±0,5mm	±5%	
	DEVIAZIONE MASSIMA DI RETTILINEARITÀ, IN PERCENTO, IN RAPPORTO ALLE DIMENSIONI DI FABBRICAZIONE CORRISPONDENTI / MAXIMUM STRAIGHTNESS DEVIATION, IN %, IN RELATION TO THE CORRESPONDING PRODUCTION DIMENSIONS / MARGE DE TOLÉRANCE DE RECTITUDE, EN POURCENTAGE, PAR RAPPORT AUX DIMENSIONS DE FABRICATION CORRESPONDANTES / ZULÄSSIGE HOCHSTABWEICHUNG DER KANTENGERADHEIT IM VERHÄLTNIS ZU DEN ENTSPRECHENDEN HERSTELLMÄßEN IN PROZENTEN / DESVIACIÓN MÁXIMA DE RECTITUD, EN TANTO POR CIENTO, EN RELACIÓN CON EL TAMAÑO DE FABRICACIÓN CORRESPONDIENTE	Non squadrato EN 14411 - ISO 13006	±0,5%	±1,5mm	±0,5%	ISO 10545-2
	Squadrato ISO 13006	±0,3%	±0,8mm	±0,10%		
	DEVIAZIONE MASSIMA DI ORTOGONALITÀ, IN PERCENTO, IN RAPPORTO ALLE DIMENSIONI DI FABBRICAZIONE CORRISPONDENTI / MAXIMUM RIGHT-ANGLE DEVIATION, IN %, IN RELATION TO THE CORRESPONDING PRODUCTION DIMENSIONS / MARGE DE TOLÉRANCE D'ANGULARITÉ, EN POURCENTAGE, PAR RAPPORT AUX DIMENSIONS DE FABRICATION / HOCHSTABWEICHUNG DER RECHTWINKELIGKEIT IM VERHÄLTNIS ZU DEN ENTSPRECHENDEN HERSTELLMÄßEN IN PROZENTEN / DESVIACIÓN MÁXIMA DE LA ORTOGONALIDAD, EN TANTO POR CIENTO, EN RELACIÓN CON EL TAMAÑO DE FABRICACIÓN CORRESPONDIENTE	Non squadrato EN 14411 - ISO 13006	±0,5%	±2,0mm	±0,5%	
	Squadrato ISO 13006	±0,3%	±1,5mm	±0,20%		
	PLANARITÀ (CURVATURA DEL CENTRO, DELLO SPIGOLO E SVERGOLAMENTO) / FLATNESS (CURVING IN THE MIDDLE, CORNER AND WARPING) / PLANÉITÉ (COURBURE CENTRALE, DE L'ARÊTE ET GAUCHISSEMENT) / EBENFLÄCHIGKEIT (KRÜMMUNG DER MITTE, DER KANTE UND VERWINDUNG) / PLANITUD (CURVATURA DEL CENTRO, DE LA ARISTA Y ABARQUILLAMIENTO)	Non squadrato EN 14411 - ISO 13006	±0,5%	±2,0mm	±0,35%	
	Squadrato ISO 13006	±0,4%	±1,8mm	±0,35%		
	QUALITÀ DELLA SUPERFICIE - SURFACE QUALITY / QUALITÉ DE LA SURFACE - QUALITÄT DER OBERFLÄCHE / CALIDAD DE LA SUPERFICIE	Il 95% min delle piastrelle deve essere esente da difetti visibili. / At least 95% of the tiles must be free from visible flaws. 95% min des carreaux ne doivent présenter aucun défaut visible. Mindestens 95% der Fliesen müssen frei von sichtbaren min. / el 95% de las baldosas tiene que estar exento de defectos visibles.		CONFORME/CONFORMING CONFORME/KONFORM CONFORME		
	MASSA D'ACQUA ASSORBITA IN % / % WATER ABSORPTION - MASSE D'EAU ABSORBÉE EN % WASSERANFAHME IN % MASA DE AGUA ABSORBIDA EN %	E≤0,5%		valore medio 0,08 %	ISO 10545-3	
	FORZA DI ROTTURA IN N (sp. ≥ 7,5 mm) - BREAKING STRENGTH IN N (thickness ≥ 7,5 mm) / FORCE DE RUPTURE EN N (ép. ≥ 7,5 mm) / BRUCHLAST IN N (Dicke ≥ 7,5 mm) / FUERZA DE ROTURA EN N (gr. ≥ 7,5 mm)	1300 min		valore medio 2200 Newton	ISO 10545-4	
	RESISTENZA ALLA FLESSIONE IN N/mm2 / N/mm2 FLEXURAL STRENGTH TEST / RÉSISTANCE A LA FLEXION EN N/mm2 / BIEGEFESTIGKEIT IN N/mm / RESISTENCIA A LA FLEXIÓN EN N/mm	35 min		valore medio 50 N/mm2	ISO 10545-4	
	RESISTENZA ALL'ABRAZIONE DELLE PIASTRELLE SMALTATE / RESISTANCE TO ABRASION OF GLAZED TILES / RESISTANCE A L'ABRASION DES CARREAUX ÉMALLÉS / TIEFENABRIEBFESTIGKEIT GLASIRTER FLIESEN / RESISTENCIA A LA ABRASION DE LAS BALDOSAS ESMALTADAS	COME DICHIARATO DAL PRODUTTORE SEE MANUFACTURER'S DECLARATION SELON DÉCLARATION DU PRODUCTEUR ENTSPRECHEND DER HERSTELLERANGABEN TAL COMO DECLARA EL FABRICANTE		vedere la serie - see the collection voir la collection - siehe der kollektion ver la coleccion	ISO 10545-7	
	RESISTENZA AGLI SBALZI TERMICI / THERMAL SHOCKS RESISTANT / RÉSISTANCE AUX VARIATIONS THERMIQUES TEMPERATURWECHSELBESTÄNDIGKEIT / RESISTENCIA AL CHOQUE TÉRMICO	-		RESISTE - RÉSISTANT RÉSISTE - ERFÜLLT RESISTE	ISO 10545-9	
	RESISTENZA ALLE MACCHIE / RESISTANCE TO STAINING / RÉSISTANCE AUX TACHES / FLECKENABWEISEND RESISTENCIA A LAS MANCHAS	Classe 3 min		≥ Classe 3	ISO 10545-14	
	RESISTENZA A BASSE CONCENTRAZIONI DI ACIDI E ALCALI. / RESISTANCE TO LOW CONCENTRATIONS OF ACIDS AND ALKALIS. / RESISTANCE A BASSES CONCENTRATIONS D'ACIDES ET ALCALIS. / WIDERSTAND GEGEN NIEDRIGE KONZENTRATIONEN VON SAUREN UND LAUGEN. / RESISTENCIA A BAJAS CONCENTRACIONES DE ACIDOS Y ALCALIS. /	COME DICHIARATO DAL PRODUTTORE SEE MANUFACTURER'S DECLARATION SELON DÉCLARATION DU PRODUCTEUR ENTSPRECHEND DER HERSTELLERANGABEN TAL COMO DECLARA EL FABRICANTE		vedere la serie - see the collection voir la collection - siehe der kollektion ver la coleccion	ISO 10545-13	
	RESISTENZA AI PRODOTTI CHIMICI DI USO DOMESTICO E AGLI ADDITIVI PER PISCINA / RESISTENCE TO DOMESTIC CHEMICAL PRODUCTS AND ADDITIVES FOR SWIMMING POOLS / RÉSISTANT AUX PRODUITS CHIMIQUES À USAGE DOMESTIQUE ET AUX ADDITIFS POUR PISCINE / WIDERSTAND GEGEN HAUSHALTSCHEMICALIEN UND SCHWIMMBADZUSATZSTOFFEN / RESISTENCIA A PRODUCTOS PARA LIMPIEZA DOMESTICA Y ADITIVOS PARA PISCINAS	GB min		GA		
	RESISTENZA AL GELO / FROST RESISTANCE - RÉSISTANCE AU GEL / FROSTSICHERHEIT - RESISTENCIA A LA HELADA	RICHIESTA / REQUIRED REQUISE / GEFORDET REQUERIDA		RESISTE - RÉSISTANT RÉSISTE - ERFÜLLT RESISTE	ISO 10545-12	
	RESISTENZA AL CAVILLO DI PIASTRELLE SMALTATE / GLAZE CRAZING RESISTANCE - RÉSISTANCE AU TRESSAILLAGE POUR LES CARREAUX ÉMALLÉS / WIDERSTAND GEGEN HAARRISS VON GLASIRTEN FLIESEN - RESISTENCIA AL CUARTEADO DE LOS AZULEJOS ESMALTADOS	RICHIESTA / REQUIRED REQUISE / GEFORDET REQUERIDA		RESISTE - RÉSISTANT RÉSISTE - ERFÜLLT RESISTE	ISO 10545-11	
	COEFFICIENTE D'ATTRITO (SCIVOLOSITÀ) / FRICTION COEFFICIENT (SLIPPERINESS) / COEFFICIENT DE FRICTION (GLISSEMENT) / REIBUNGSKOEFFIZIENT (SCHLUPFRIGKEIT) - COEFICIENTE DE ANTI DESLIZAMIENTO	-		vedere la serie - see the collection voir la collection - siehe der kollektion ver la coleccion	-	

Per un effetto ottimale della posa, fiorim suggerisce di mantenere 2 mm di fuga per pose monofornate e 3 mm per combinare formati misti / For optimal installation results, fiorim recommends maintaining a joint of 2 mm 1/12" for single format installations and 3 mm 1/8" to combine mixed formats / Pour réaliser une pose parfaite, fiorim suggère de maintenir 2 mm de joint pour la pose des monofornats, et 3 mm pour les combinaisons de formats mixtes / Um einen optimalen effekt beim verlegen zu erzielen empfehlt fiorim eine 2 mm fuge bei einformatigen verlegungen und 3 mm fuge bei formatkombinationen / Para lograr los máximos resultados en la posa del producto, fiorim aconseja 2 mm de junta en aplicaciones monofornato y 3 mm en combinaciones de formatos mixtos

Per informazioni relative ai dati tecnici su marcatura CE vedere il sito www.fiorim.com / Please refer to our web site www.fiorim.com for technical information related to CE labeling / Pour tout renseignement sur l'avis technique de la marque CE veuillez consulter le site www.fiorim.com / Informationen bezüglich technischer Daten zur Beschriftung CE entnehmen Sie unserer Website www.fiorim.com / Para obtener más información y descargar las marcas CE: www.fiorim.com

MOSAICO DI VETRO - GLASS MOSAIC TILES - MOSAÏQUE EN VERRE - GLASMOSAÏK - MOSAICO VÍTREO			
CARATTERISTICHE TECNICHE - TECHNICAL CHARACTERISTICS - CARACTERISTIQUES TECHNIQUES - TECHNISCHE EIGENSCHAFTEN - CARACTERÍSTICAS TÉCNICAS			
	MASSA D'ACQUA ASSORBITA IN % / % WATER ABSORPTION / MASSE D'EAU ABSORBÉE EN % / WASSERAUFNAHME IN % MASA DE AGUA ABSORBIDA EN %	0%	ISO 10545-3
	RESISTENZA ALL'ABRAZIONE / RESISTANCE TO ABRASION / RÉSISTANCE À L'ABRASION / ABRIEBHÄRTE RESISTENCIA A LA ABRASIÓN	5*	ISO 10545-7
	DILATAZIONE TERMICA LINEARE (10 ⁻⁶ C ⁻¹) LINEAR THERMAL EXPANSION (10 ⁻⁶ C ⁻¹) DILATATION THERMIQUE LINEAIRE (10 ⁻⁶ C ⁻¹) LINEARE THERMISCHE DEHNUNG (10 ⁻⁶ C ⁻¹) DILATACION TERMICA LINEAL (10 ⁻⁶ C ⁻¹)	9,1 *10 ⁻⁶ °C ⁻¹	ISO 10545-8
	RESISTENZA AL CAVILLO DI PIASTRELLE SMALTATE / GLAZE CRAZING RESISTANCE / RÉSISTANCE AU TRESSAILLAGE POUR LES CARREAUX ÉMAILLÉS / WIDERSTAND GEGEN HAARRISSEN VON GLASIERTEN FLIESEN - RESISTENCIA AL CUARTEADO DE LOS AZULEJOS ESMALTADOS	RESISTE - RESISTANT RESISTE - ERFÜLLT RESISTE	ISO 10545-11
	RESISTENZA ALLE MACCHIE / RESISTANCE TO STAINING / RÉSISTANCE AUX TACHES / FLECKENABWEISEND RESISTENCIA A LAS MANCHAS	Classe 5	ISO 10545-14
	RESISTENZA A BASSE CONCENTRAZIONI DI ACIDI E ALCALI / RESISTANCE TO LOW CONCENTRATIONS OF ACIDS AND ALKALIS. / RESISTANCE A BASSES CONCENTRATIONS D'ACIDES ET ALCALIS. / WIDERSTAND GEGEN NIEDRIGE KONZENTRATIONEN VON SÄUREN UND LAUGEN. / RESISTENCIA A BAJAS CONCENTRACIONES DE ACIDOS Y ALCALIS.	Classe GLA - ULA	ISO 10545-13
	RESISTENZA A ALTE CONCENTRAZIONI DI ACIDI ED ALCALI / RESISTANCE TO HIGH CONCENTRATIONS OF ACIDS AND ALKALI / RESISTANCE À DE HAUTES CONCENTRATIONS D'ACIDES ET BASES / BESTÄNDIGKEIT GEGEN STARK KONZENTRIERTE SÄUREN UND LAUGEN / RESISTENCIA A ALTAS CONCENTRACIONES DE ACIDOS Y ALCALIS	Classe GHA - UHA	
	RESISTENZA AI PRODOTTI CHIMICI DI USO DOMESTICO E AGLI ADDITIVI PER PISCINA / RESISTENCE TO DOMESTIC CHEMICAL PRODUCTS AND ADDITIVES FOR SWIMMING POOLS / RÉSISTANT AUX PRODUITS CHIMIQUES À USAGE DOMESTIQUE ET AUX ADDITIFS POUR PISCINE / WIDERSTAND GEGEN HAUSHALTSHEMIKALIEN UND SCHWIMMBADZUSATZSTOFFEN / RESISTENCIA A PRODUCTOS PARA LIMPIEZA DOMESTICA Y ADITIVOS PARA PISCINAS	Classe GA - UA	
	RESISTENZA DEI COLORI ALLA LUCE COLOURS' RESISTANCE TO FADING RÉSISTANCE DES COULEURS À LA LUMIÈRE FARBBESTÄNDIGKEIT RESISTENCIA DE LOS COLORES A LA LUZ	RESISTE - RESISTANT RESISTE - ERFÜLLT RESISTE	DIN 51094
	COEFFICIENTE D'ATTRITO (SCIVOLOSITÀ) / FRICTION COEFFICIENT (SLIPPERINESS) / COEFFICIENT DE FRICTION (GLISSEMENT) / REIBUNGSKOEFFIZIENT (SCHLÜPFRIEGKEIT) - COEFICIENTE DE ANTI DESLIZAMIENTO	A + B + C	DIN 51097

*PROVA ESEGUITA SU WHITE - TEST CARRIED OUT ON WHITE - ESSAI EXÉCUTÉ SUR WHITE - PROBEN DURCHGEFÜHRT WHITE - PRUEBA EJECUTADA SOBRE WHITE

CERTIFICAZIONI

CERTIFICATIONS

CERTIFICATIONS

ZERTIFIZIERUNGEN

CERTIFICACIONES

Certificazione di sistema / System certification / Certification de système / Systemzertifizierung / Certificación de sistema

La soddisfazione del Cliente, nel rispetto dell'Ambiente e della Sicurezza dei propri collaboratori, è la condizione essenziale per il successo della nostra azienda. Di conseguenza, Florim si impegna a porre come obiettivo prioritario il costante miglioramento dei propri prodotti e servizi. Florim Ceramiche S.p.A SB è la prima azienda nel settore a ottenere la certificazione del proprio Sistema di Gestione della Qualità, dell'Ambiente e della Salute e Sicurezza dei lavoratori e dell'Energia, in base alle norme **UNI EN ISO 9001, UNI EN ISO 14001, ISO 45001 e UNI EN ISO 50001**, relativamente a progettazione, produzione e vendita di piastrelle ceramiche in tutte le tipologie produttive.

Customer satisfaction, together with respect for the environment and for the safety of those who work with us are essential conditions for our company's success. As a result, Florim is committed to making the constant improvement of its products and services a priority. Florim Ceramiche S.p.A SB is the first company in the sector to obtain certification for its Quality Management System, its Environmental Management System and its Management System for the Health and Safety of workers and energy, according to **UNI EN ISO 9001, UNI EN ISO 14001, ISO 45001 and UNI EN ISO 50001** standards, relating to the design, manufacture and sales of ceramic tiles in all of its production types.

La satisfaction du client, dans le respect de l'environnement et de la sécurité de ses collaborateurs, est la condition essentielle au succès de notre entreprise. Florim s'engage donc à faire de l'amélioration constante de ses produits et services un objectif prioritaire. Florim Ceramiche S.p.A SB est la première entreprise du secteur à obtenir la certification de son système de gestion de la qualité, de l'environnement, de la santé et de la sécurité des employés et de énergie, conformément aux normes **UNI EN ISO 9001, UNI EN ISO 14001, ISO 45001 et UNI EN ISO 50001**, en matière de conception, production et vente de tous types de carreaux céramiques.

Die Zufriedenheit des Kunden unter Berücksichtigung von Umwelt und Sicherheit unserer Mitarbeiter ist die grundlegende Bedingung für den Erfolg unseres Unternehmens. Demzufolge setzt sich die Firma Florim dafür ein, die ständige Verbesserung ihrer Produkte und Dienstleistungen zum vorrangigen Ziel zu machen. Die Firma Florim Ceramiche S.p.A SB ist das erste Unternehmen in diesem Fachbereich, das die Zertifizierung seines Managementsystems der Qualität, Umwelt und Gesundheit und Sicherheit, und energie auf Grund der Bestimmungen **UNI EN ISO 9001, UNI EN ISO 14001, ISO 45001 und UNI EN ISO 50001**, in Bezug auf Entwurf, Produktion und Verkauf von Keramikfliesen in allen Herstellungsarten erhielt.

La satisfacción del Cliente, con un respeto total del ambiente y seguridad de sus colaboradores, representa la condición esencial para el éxito de nuestra empresa. Por ello, Florim se compromete a perseguir, como objetivo prioritario, una mejora constante de sus productos y servicios. Florim Ceramiche S.p.A SB es la primera empresa en el sector que ha obtenido el certificado del Sistema de Gestión de la Calidad, Ambiente, Salud y Seguridad de los trabajadores y energía en base a la normativa **UNI EN ISO 9001, UNI EN ISO 14001, BS OHSAS 18001 y UNI EN ISO 50001**, en relación al proyecto, producción y venta de baldosas de cerámica en todas las tipologías productivas.



Certificazioni ambientali di prodotto / Product environmental certifications / Certifications environnementales des produits / Produktzertifizierungen im zeichen des umweltschutzes / Certificaciones ambientales de producto



GREENGUARD

Certification is the very first voluntary North American indoor air quality product certification created specifically for commercial building products, this certification requires that products meet stringent chemical emissions requirements for over 360 VOCs, plus a limit on the total of all chemical emissions combined. Products undergo routine monitoring and annual retesting to ensure continued compliance with the **GREENGUARD** Certification standard.



GREENGUARD GOLD

Certification was developed with the specific health sensitivities of children and other vulnerable health populations in mind and based on key criteria from public health agencies, this certification sets some of the world's most stringent emission limits on over 360 chemicals, a limit on total chemical emissions, and a limit on phthalate emissions. Products undergo routine monitoring and annual retesting to ensure continued compliance with the **GREENGUARD Gold** standard.

GREENGUARD / GREENGUARD GOLD

Per ulteriori informazioni e approfondimenti / For further details and information / Pour approfondir et obtenir de plus amples informations / Für weitere Informationen / Para obtener más información

Certificazioni ambientali di prodotto / Product environmental certifications / Certifications environnementales des produits
Produktzertifizierungen im Zeichen des Umweltschutzes / Certificaciones ambientales de producto



BUREAU VERITAS

Bureau Veritas è il marchio che certifica la natura riciclata del materiale di cui è composto un prodotto, sottoponendo a verifica l'intero ciclo produttivo. Viene controllata e documentata la provenienza dei materiali di riciclo, il loro dosaggio, il rispetto di alcune peculiarità tecnologiche e il raggiungimento dei parametri stabiliti della norma ISO14021:2002 dell'International Organization for Standardization e del regolamento LEED 2.2 NC del U.S. Green Building Council (USGBC). Per maggiori informazioni: www.bureauveritas.com

Bureau Veritas is the mark that certifies the recycling of the material that goes into the making of a product, by running an inspection on the entire production cycle. Checks and documentation are carried out on the provenance of the recycled material, the quantities used, the observance of certain technological particulars and the achievement of the parameters established by the ISO14021:2002 regulations of the International Organization for Standardization and the LEED 2.2 NC regulation of the U.S. Green Building Council (USGBC). For more information: www.bureauveritas.com

Bureau Veritas est une marque qui certifie que le matériau dont un produit est composé a été recyclé, en soumettant l'ensemble du cycle de production à une vérification. La provenance des matériaux recyclés est contrôlée et prouvée, de même que leur dosage et le respect de certaines caractéristiques technologiques et des paramètres définis par la norme ISO14021:2002 de l'Organisation internationale de normalisation et le règlement LEED 2.2 NC de l'U.S. Green Building Council (USGBC). Pour plus d'informations : www.bureauveritas.com

Bureau Veritas ist ein Markenzeichen, das die rezyklierte Art des Materials zertifiziert, aus dem ein Produkt besteht und dazu den gesamten Produktionszyklus prüft. Kontrolliert und beurkundet wird die Herkunft der rezyklierten Materialien, deren Dosierung, die Einhaltung einiger technologischer Eigenschaften und das Erreichen der Parameter, die von den Vorschriften ISO14021:2002 der International Organization for Standardization und von den LEED-Vorschriften 2.2 NC des U.S. Green Building Council (USGBC) vorgeschrieben werden. Für weitere Infos siehe: www.bureauveritas.com

Bureau Veritas es la marca que certifica la naturaleza reciclada del material con el que está hecho un producto, sometiendo a control todo el ciclo productivo. Se controla y documenta la proveniencia de los materiales reciclados, su dosificación, que se respeten algunas peculiaridades tecnológicas y que se alcancen los parámetros establecidos por la norma ISO14021:2002 de la International Organization for Standardization y del reglamento LEED 2.2 NC del U.S. Green Building Council (USGBC). Para más información: www.bureauveritas.com

Florim e l'ambiente

Florim and the environment / Florim et l'environnement / Florim und die Umwelt / Florim y el ambiente



ENVIRONMENT PRIORITY ONE / Using nature's resources responsibly

Per sottolineare l'attenzione e l'impegno verso la tutela dell'ambiente, in accordo con la norma ISO 14021 (Environmental labels and declarations) Florim afferma il proprio impegno nella continua innovazione tecnologica dei processi industriali.

To underline our care for the environment and our pledge to protect it in accordance with the ISO 14021 standards (Environmental labels and declarations), Florim affirms its commitment to continual technological innovation of the industrial processes in order.

Pour prouver l'attention qu'elle consacre depuis toujours à la protection de l'environnement, en accord avec la norme ISO 14021 (Environmental labels and declarations), la société Florim déclare son engagement dans l'innovation technologique continue des processus industriels.

Die Firma Florim möchte ihre Aufmerksamkeit und ihr Engagement zum Schutz der Umwelt gemäß der ISO-Norm 14021 (Environmental labels and declarations) hervorheben und bekräftigt deshalb, dass sie ständig auf technologische Innovation der Industrie prozesse.

Para subrayar la atención y el compromiso adquirido con la tutela del medio ambiente, de acuerdo con la norma ISO 14021 (Environmental labels and declarations) Florim reafirma su dedicación por la continua innovación tecnológica de los procesos industriales.

Certificati di prova / Test certificates / Certifications de produit / Produktzertifizierungen / Certificaciones de producto



I certificati di prova sono disponibili direttamente sui siti Internet dei vari brand, nella sezione Prove Tecniche dedicata alle diverse collezioni.

Per ulteriori informazioni e approfondimenti: www.florim.com

The test certificates are available directly on the websites of the various brands, in the Technical Test section dedicated to the different collections.

For further details and information: www.florim.com

Les certificats de test de performance sont disponibles directement sur les sites Internet des différentes marques, dans la section Essais Techniques consacrée aux différentes collections. Pour approfondir et obtenir de plus amples informations: www.florim.com

Die Prüfbescheinigungen sind direkt auf den Internetseiten der entsprechenden Brands im Bereich Technische Prüfungen der verschiedenen Kollektionen verfügbar. Für weitere Informationen: www.florim.com

Los certificados de ensayo están disponibles directamente en los sitios internet de las diferentes marcas, en la sección Ensayos Técnicos dedicada a las diferentes colecciones. Para obtener más información: www.florim.com

Marcatura CE / CE Mark / Marquage CE / CE-Kennzeichnung / Marca CE



Per ulteriori informazioni, approfondimenti e download delle marcature CE: www.florim.com

For further details and information and to download the CE marks: www.florim.com

Pour obtenir de plus amples informations, approfondir et télécharger les marquages CE: www.florim.com

Für weitere Informationen und Downloads der CE-Kennzeichnungen: www.florim.com

Para obtener más información y descargar las marcas CE: www.florim.com

Certificazioni di prodotto nazionali / National product certifications / Certifications de produit nationaux

Nationale Produktzertifizierungen Certificaciones de producto nacionales



放射性水平 A 类

Certificazione obbligatoria per l'esportazione in Cina
Certification mandatory for export to China
Certification obligatoire pour l'exportation en Chine
Für den Export nach China obligatorische Zertifizierung
Certificación obligatoria para la exportación a China

Per soddisfare le richieste di norme e regolamenti locali, vi sono anche diverse certificazioni di prodotto nazionali.

Per informazioni in merito contattare www.florim.com

To cater for the requirements of local norms and regulations, various national product certifications also exist. For more details contact www.florim.com

Pour satisfaire les exigences des normes et réglementations locales, il existe également différentes certifications nationales de produit.

Pour de plus amples informations à ce sujet contacter www.florim.com

Darüber hinaus sind auch verschiedene nationale Produktzertifizierungen vorhanden, um die lokalen Anforderungen bezüglich Richtlinien und Reglementen zu erfüllen. Für Informationen dazu wenden Sie sich bitte an www.florim.com

Para satisfacer los requisitos previstos por las normas y reglamentos locales, hay también varias certificaciones de producto nacionales. Para obtener más información, contacte con www.florim.com



UPEC

QB-UPEC

Per informazioni relative ai dati tecnici sulla classificazione UPEC vedi il sito www.florim.com

Pour toute information concernant les données techniques sur la classification UPEC, nous vous prions de bien vouloir consulter la version française du site www.florim.com



WallPEC

QB-WallPEC

Per informazioni relative ai dati tecnici sulla classificazione WallPEC vedi il sito www.florim.com

Pour toute information concernant les données techniques sur la classification WallPEC, nous vous prions de bien vouloir consulter la version française du site www.florim.com

U.S. GREEN BUILDING COUNCIL



Florim ha aderito volontariamente all'U.S. Green Building Council (USGBC), la più importante associazione statunitense di industrie appartenenti al settore edilizio, unite per promuovere edifici costruiti in accordo a precise disposizioni riguardanti la sostenibilità ambientale che sono incluse all'interno della certificazione LEED (Leadership in Energy and Environmental Design), un sistema a punteggio che misura la sostenibilità di un progetto. L'utilizzo di prodotti Florim contribuisce a ottenere punti per l'acquisizione della certificazione LEED.

Florim has voluntarily become a member of the U.S. Green Building Council (USGBC), the most important American association dedicated to environmentally sustainable building design and construction according to precise directives, which must be followed in order to obtain LEED (Leadership in Energy and Environmental Design) certification, a rating system that measures the sustainability of a project. Using Florim products contributes to getting points to achieve LEED certification.

Florim a adhéré volontairement à l'U.S. Green Building Council (USGBC), la plus grande association américaine d'industries appartenant à la filière BTP, unies pour promouvoir la réalisation de constructions conformes aux dispositions précises édictées en matière de durabilité environnementale, incluses dans la certification LEED (Leadership in Energy and Environmental Design), un système d'attribution de notes mesurant la durabilité d'un projet. L'utilisation des produits Florim contribue à l'obtention de points en vue de la certification LEED.

Florim ist freiwillig dem U.S. Green Building Council (USGBC) beigetreten, dem bedeutendsten Verband der Bauindustrien in den Vereinigten Staaten, die sich zur Förderung von Gebäuden vereinigt haben, die gewissen Nachhaltigkeitsvorschriften entsprechend gebaut werden. Diese Bestimmungen sind in der LEED-Zertifizierung (Leadership in Energy and Environmental Design), einem Punktesystem zur Bewertung der Nachhaltigkeit eines Projekts, enthalten. Der Gebrauch von Florim Produkten trägt zur Erlangung von Punkten der LEED-Zertifizierung bei.

Florim ha adherido voluntariamente al U.S. Green Building Council (USGBC), la más importante asociación estadounidense de industrias pertenecientes al sector de la construcción, unidas para promover la construcción de edificios de acuerdo con precisas disposiciones relativas a la sostenibilidad ambiental, que están incluidas en la certificación LEED (Leadership in Energy and Environmental Design), un sistema por puntos que mide la sostenibilidad de un proyecto. El uso de productos Florim contribuye a obtener puntos para adquirir la certificación LEED.

La certificazione LEED è una certificazione di edificio non di prodotto. Pertanto i criteri LEED fanno sempre riferimento al sistema edificio e non ai singoli materiali utilizzati nel progetto. La soglia indicata nei crediti si riferisce quindi al parametro cui l'edificio dovrà conformarsi per l'attribuzione del relativo punteggio. Sul sito Florim.com, All'interno delle certificazioni di ogni singola collezione, è disponibile la Certification Letters for LEED® Projects.

LEED certification is a building certification and not for a product. Therefore, the LEED criteria always refer to the building system and not to the individual building materials used in the project. The threshold indicated in the credits, therefore refers to the parameter to which the building must comply with for the allocation of the corresponding point score. Certification Letters for LEED® Projects are available on the Florim.com website, in the certifications for each single collection.

La certification LEED (« Leadership in Energy and Environmental Design ») est une certification qui concerne les bâtiments et non pas les produits. Ainsi, les critères LEED font toujours référence au système bâtiment et non pas aux matériaux utilisés dans le projet. Le seuil indiqué dans les crédits se réfère donc au paramètre auquel le bâtiment devra se conformer pour l'attribution des points correspondants. Sur le site Florim.com, parmi les certifications de chaque collection, la Certification Letters for LEED® Projects est disponible.

Bei der LEED-Zertifizierung handelt es sich nicht um ein Produkt- sondern ein Gebäudezertifizierungssystem. Daher beziehen sich die LEED-Kriterien immer auf das Gebäude im Ganzen, nicht auf die einzelnen für das Projekt verwendeten Materialien. Der für die Punkte angegebene Grenzwert bezieht sich daher auf den Wert, den das Gebäude einhalten muss, um die entsprechenden Punkte zu erhalten. Auf der Website Florim.com finden sich in den Zertifizierungen der einzelnen Kollektionen die Certification Letters for LEED® Projects.

La certificación LEED es una certificación para el edificio y no para el producto. Por lo tanto los criterios LEED siempre se refieren al sistema edificio y no a cada uno de los materiales utilizados en el proyecto. El umbral indicado en los créditos se refiere por lo tanto al parámetro al cual el edificio se deberá ajustar para que le sea atribuida la correspondiente puntuación. En el sitio web Florim.com, en la sección de las certificaciones de cada colección, están disponibles las Certification Letters for LEED® Projects.



ENVIRONMENTAL PRODUCT DECLARATION

L'EPD è una Dichiarazione Ambientale di Prodotto certificata e verificata in modo indipendente, che esprime in modo trasparente e oggettivo le prestazioni ambientali di un prodotto lungo il suo ciclo di vita, in accordo con lo Standard internazionale ISO14025. L'EPD è basata su specifiche regole che ne definiscono le metodologie di calcolo: le Product Category Rules (PCR), e non prevede soglie prestazioni.

The EPD is a certified and independently verified Environmental Product Declaration that expresses in a transparent and objective manner the environmental performance of a product throughout its life cycle, in accordance with the International Standard ISO14025. The EPD is based on specific rules that define the calculation methodologies: the Product Category Rules (PCR), and does not provide for performance thresholds.

La DEP est une Déclaration Environnementale de Produit certifiée et vérifiée de façon indépendante, décrivant de manière transparente et objective les performances environnementales d'un produit tout au long de son cycle de vie, conformément à la norme internationale ISO 14025. La DEP s'appuie sur des règles spécifiques qui définissent ses méthodes de calcul : les Product Category Rules (PCR), et ne prévoit pas de seuils de performance.

EPD ist eine zertifizierte und unabhängig kontrollierte Produkt-Umwelterklärung, die, übereinstimmend mit der internationalen Norm ISO14025, auf transparente und objektive Weise die Umweltleistungen eines Produkts während seines Lebenszyklus bekundet. EPD basiert auf spezifischen Regeln, die die Berechnungsmethode festlegen: die Product Category Rules (PCR), die keine Leistungsschwellen vorsehen.

La DAP es una declaración ambiental de producto, certificada y verificada de manera independiente, que informa acerca del desempeño ambiental de un producto a lo largo de su ciclo de vida de forma transparente y objetiva, de conformidad con la norma internacional ISO 14025. La DAP se basa en reglas específicas que definen sus métodos de cálculo, denominadas Reglas de categoría de producto (RCP), y no prevé umbrales de desempeño.

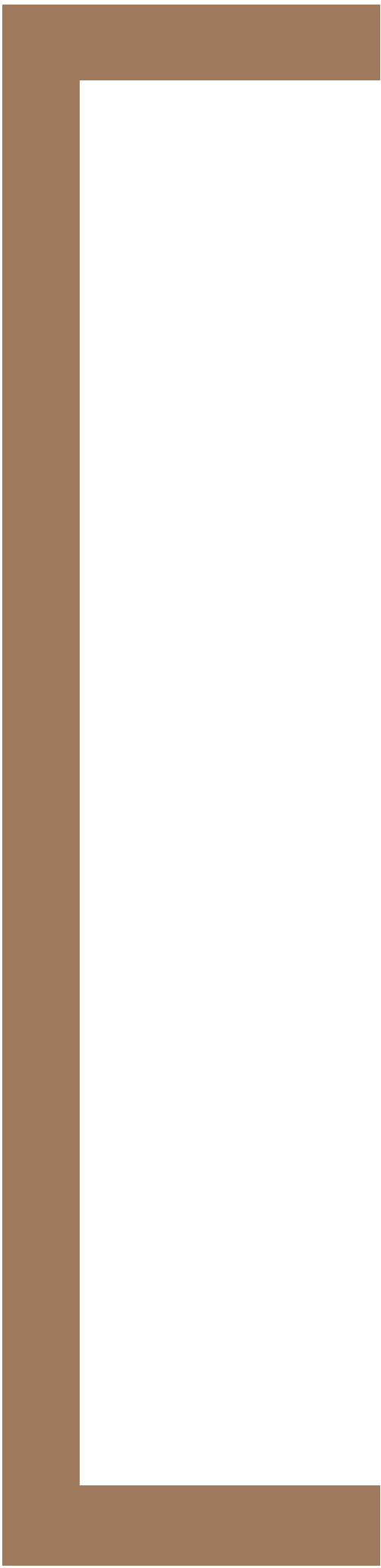

CONDIZIONI GENERALI DI VENDITA

GENERAL CONDITIONS OF SALE
CONDITIONS GÉNÉRALES DE VENTE
ALLGEMEINE GESCHÄFTSBEDINGUNGEN
CONDICIONES GENERALES DE VENTA

CONDICIONES GENERALES DE VENTA

1 NORMATIVA CONTRACTUAL

Salvo modificaciones o derogaciones acordadas por escrito, las presentes condiciones generales disciplinan todos los contratos de venta entre Florim Ceramiche S.p.A. SB y el Comprador sin necesidad de una referencia expresa a ellos. Las variaciones de las condiciones generales de venta, ofertas, bonificaciones o descuentos, acordados por nuestros agentes o por otros intermediarios, solo son válidas previa aceptación escrita de nuestra empresa.

2 OBJETO DEL SUMINISTRO

El suministro comprende solamente los materiales, prestaciones y cantidades especificados en nuestra confirmación de pedido. El texto de la confirmación de pedido de Florim Ceramiche S.p.A. SB prevalecerá siempre sobre el texto de cualquier oferta o pedido.

3 CONFIRMACIÓN DE PEDIDO

Si la confirmación de pedido de Florim Ceramiche S.p.A. SB difiere de los acuerdos o pedidos en cuanto a los elementos que la componen, el Comprador podrá enviar la correspondiente reclamación por escrito en el plazo de 7 días a partir de la recepción de nuestra confirmación; en caso contrario, esta se considerará aceptada tal como ha sido redactada. Si el lugar de entrega de la mercancía es diferente del indicado en la confirmación de pedido, el cliente se compromete a comunicarlo a Florim Ceramiche S.p.A. SB antes del día previsto para el retiro en la sede de esta última. Dicha comunicación se debe realizar por correo, telefax o correo electrónico, y debe incluir los datos identificativos del destinatario de los bienes y del lugar en el que se debe realizar la entrega. En defecto de esta comunicación, el destino indicado originalmente se considera tácitamente confirmado.

4 PRECIOS

Los precios indicados en las listas Florim Ceramiche S.p.A. SB no son vinculantes: en consecuencia, nos reservamos el derecho a modificarlos antes de la aceptación del pedido. Los precios acordados para cada venta son netos, con pago en efectivo y entrega franco fábrica, salvo acuerdo escrito en contrario. Si entre la fecha del pedido (incluso después de la confirmación de la oferta) y la fecha de entrega se verifican aumentos en los costes de las materias primas, mano de obra, combustibles, gastos de producción, transporte, etc. y en caso de variaciones importantes en los tipos de cambio entre la divisa de facturación y la divisa interna, Florim Ceramiche S.p.A. SB podrá aumentar el precio acordado, comunicándolo por escrito al Comprador (también por telefax o correo electrónico). Si dicho precio supera en un 20 % el acordado en el momento del pedido, el Comprador podrá rescindir el contrato, comunicando su decisión por correo certificado en el plazo perentorio de 10 días a partir de la recepción de la notificación de aumento de precio. En su defecto, el nuevo precio se considerará aceptado.

5 ENTREGAS

La venta, salvo acuerdo escrito en sentido contrario, siempre es franco fábrica Florim Ceramiche S.p.A. SB. La mercancía viaja a cargo y riesgo del Comprador. Toda responsabilidad nuestra cesa en el momento de la entrega al transportista, ante el cual, una vez realizados los controles necesarios, el Comprador deberá plantear sus eventuales reclamaciones. Los envíos al exterior, por vía marítima o terrestre, se realizan según las condiciones establecidas en cada caso, indicadas en los "Incoterms" aprobados por la Cámara de Comercio Internacional.

6 PLAZOS DE ENTREGA

Los plazos de entrega tienen carácter indicativo; eventuales retrasos de las entregas, interrupciones y suspensiones totales o parciales de los suministros no darán derecho a indemnizaciones o resarcimientos de daños, salvo acuerdo escrito en contrario.

7 MUESTRAS

Los datos indicados en los documentos ilustrativos de Florim Ceramiche S.p.A. SB, así como las características de las muestras y modelos enviados por este último al Comprador, tienen carácter indicativo. Estos datos no tienen valor vinculante, excepto en la medida en que hayan sido expresamente mencionados como tales en la oferta o en la aceptación escrita de Florim Ceramiche S.p.A. SB.

8 PAGOS

Las facturas de Florim Ceramiche S.p.A. SB pueden ser emitidas el día de suministro, con cadencia quincenal o mensual y su importe neto debe ser pagado en el plazo acordado. Todas las obligaciones de pago entre las partes contratantes se deben cumplir en la sede de Florim Ceramiche S.p.A. SB. Eventuales pagos efectuados a agentes, representantes o auxiliares de comercio de Florim Ceramiche S.p.A. SB no se considerarán realizados hasta el momento en que las sumas correspondientes sean acreditadas a Florim Ceramiche S.p.A. SB. Salvo acuerdo escrito en contrario, el pago se deberá realizar en el momento de la entrega, en el banco indicado por Florim Ceramiche S.p.A. SB. Cualquier retraso o irregularidad en el pago da a Florim Ceramiche S.p.A. SB derecho a suspender los suministros o a resolver los contratos en curso, incluso si no corresponden a los pagos incumplidos, así como al resarcimiento de los eventuales daños. En todo caso, a partir del vencimiento del pago y sin necesidad de declaración de mora, Florim Ceramiche S.p.A. SB tiene derecho a percibir los intereses de mora en la medida prevista por el decreto legislativo N° 231 del 09/10/2002. En caso de incumplimiento, incluso parcial, los intereses de mora sobre el importe no pagado se calcularán a partir del día de la entrega, incluso si el plazo de pago había sido acordado en una fecha posterior. Ninguna reclamación o controversia inherente a la calidad de la mercancía, imperfecciones, defectos o cualquier otro aspecto del contrato será eficaz ni podrá ser tomada en consideración, y ninguna acción podrá ser iniciada, hasta el pago integral del precio (cláusula solve et repete). No se admiten compensaciones con eventuales créditos de cualquier naturaleza ante Florim Ceramiche S.p.A. SB.

9 GARANTÍAS Y RECLAMACIONES

La calidad del material cerámico se define sobre la base de las normas internacionales aplicables a la clase de producto correspondiente. Florim Ceramiche S.p.A. SB garantiza solo la mercancía de primera calidad. Reclamaciones relativas a mercancía de otras calidades (calidad B, comercial, segunda, tercera, secundaria, existencias, etc.) no serán tomadas en consideración, ni se dará ningún tipo de garantía —implícita o explícita— sobre dicho material. El Comprador tiene la obligación de verificar la calidad y cantidad de la mercancía en breve plazo después de su recepción y, en caso de reclamarlo, comunicarlo por escrito en el plazo de 8 (ocho) días a partir de la recepción, bajo pena de caducidad de cualquier derecho. El material considerado defectuoso deberá ser puesto a disposición de Florim Ceramiche S.p.A. SB para los controles que considere necesarios; cualquier otra acción (restitución, reparación, etc.) deberá ser autorizada previamente por Florim Ceramiche S.p.A. SB en forma escrita. Las reclamaciones y solicitudes de intervención en garantía después de la colocación no serán consideradas en el caso de que el defecto reclamado resulte manifiesto (por ejemplo: desportilladuras, defectos dimensionales, diferencias de tono, etc.). Se señala que la primera calidad puede contener hasta un 5 % de baldosas defectuosas y que el tono del material suministrado puede diferir de la muestra expuesta, dado que la cerámica es intrínsecamente variable en su aspecto. Las reclamaciones por defectos o imperfecciones ocultos deberán ser formalizadas por escrito en el plazo de 8 (ocho) días a partir de su descubrimiento; en todo caso, en el plazo de un año a partir de la entrega, bajo pena de caducidad de cualquier derecho a garantía y resarcimiento. Además de los datos de facturación, la comunicación deberá contener una precisa descripción del defecto y un presupuesto de los costes de reparación o modificación del producto; en ausencia de estos datos, la reclamación se considerará nula. Si la reclamación resulta infundada, el Comprador deberá resarcir a Florim Ceramiche S.p.A. SB todos los gastos realizados para la verificación (viajes, peritajes, etc.). En todo caso, la obligación de Florim Ceramiche S.p.A. SB se limita a la sustitución de las piezas defectuosas o a la reparación, quedando expresamente excluidas otras indemnizaciones, como - a título indicativo, no limitativo - costes de desplazamiento y re colocación de mobiliario, equipo, maquinaria, etc., lucro cesante debido a la interrupción o suspensión de actividades, molestias, daños indirectos, etc. La presencia de baldosas defectuosas no afecta la calidad del suministro en su conjunto, ni comporta la obligación de su sustitución integral. La duración de la garantía es la establecida por el código civil italiano.

10 RESERVA DE DOMINIO

La venta de la mercancía se realiza con cláusula de reserva de dominio; por lo tanto, si los acuerdos contractuales prevén que el pago debe ser realizado - total o parcialmente - después de la entrega, los productos entregados seguirán siendo propiedad de Florim Ceramiche S.p.A. SB hasta el pago integral del precio.

11 CESIÓN DEL CONTRATO

El Comprador no puede ceder su posición en el contrato ni en relaciones obligatorias eventualmente derivadas del mismo, sin la aceptación escrita de Florim Ceramiche S.p.A. SB. En tal caso, el Comprador seguirá siendo responsable solidariamente con el cesionario de las obligaciones cedidas.

12 PROPIEDAD INDUSTRIAL Y DISTRIBUCIÓN SELECTIVA - LÍMITES DE REVENTA

Florim Ceramiche S.p.A. SB es titular y legítimo poseedor de la exclusividad de las marcas, dibujos y patentes de invención. Con el objetivo de garantizar adecuadamente el respeto de los derechos exclusivos de Florim Ceramiche S.p.A. SB, así como las expectativas de los consumidores finales en cuanto a las características cualitativas previstas, Florim Ceramiche S.p.A. SB controla la distribución de sus productos mediante un sistema de distribución selectiva. Los suministros enviados por Florim Ceramiche S.p.A. SB y por los puntos de venta autorizados están destinados a la instalación por parte del usuario final o está permitida ninguna forma de reventa a otros intermediarios comerciales diferentes de los usuarios finales, salvo previa autorización escrita de Florim Ceramiche S.p.A. SB. Por lo tanto, la reventa de mercancía que viole esta prohibición se debe considerar no permitida y equiparada a un uso ilícito de los derechos de propiedad industrial e intelectual de Florim Ceramiche S.p.A. SB, con derecho de esta última a solicitar la incautación de la mercancía a cualquier poseedor. Florim Ceramiche S.p.A. SB se reserva el derecho a proceder judicialmente contra todo aquel que esté involucrado en reventas no autorizadas.

13 LEY DEL CONTRATO - TRIBUNAL COMPETENTE

El contrato está disciplinado por la ley italiana, incluidos los Usos del Sector de la Provincia de Módena. Para cualquier controversia derivada del contrato de suministro, tanto por parte de Florim Ceramiche S.p.A. SB como por parte del Comprador, tiene competencia exclusiva el Tribunal de Módena. No obstante, es facultad de Florim Ceramiche S.p.A. SB recurrir a foro competidores o diferentes.

14 SEGURIDAD DE LA CADENA LOGÍSTICA

Florim Ceramiche S.p.A. SB, con la finalidad de garantizar la seguridad de la cadena logística internacional, les ruega a sus propios CLIENTES el respeto de unos requisitos estándar para garantizar la seguridad de las mercancías objeto de relaciones contractuales y para garantizar su conformidad con la normativa AEO - Operador Económico Autorizado - Aduanas, en toda la Comunidad Europea. Los CLIENTES de Florim Ceramiche S.p.A. SB se comprometen a garantizar que las mercancías recogidas en consigna o consignadas sean expedidas o transportadas, almacenadas, preparadas o cargadas en locales seguros y en zonas de carga y expedición seguras, protegidas contra manumisiones no autorizadas, utilizando solo personal interno autorizado y oportunamente instruido.

Todos los artículos del presente listín se venden exclusivamente en cajas completas.

EL PRESENTE LISTÍN ANULA Y SUSTITUYE LOS LISTINES ANTERIORES.

Quanto contenuto nel catalogo è indicativo e non esaustivo riguardo alle grafiche, decori e ai colori riportati.

Contents of this catalog is indicative and not exhaustive with regard to graphics, decors and colors shown.
Le contenu du catalogue est indicatif et non exhaustif en ce qui concerne graphiques, décors et couleurs indiquées.
Die Beschreibungen im Katalog sind indikativ und nicht allumfassend in Bezug auf Grafiken, Dekore und Farben.
El contenido de este catálogo es indicativo y no exhaustivo con respecto a gráficas, decoros y colores ilustrados.



Florim Ceramiche S.p.A. SB

Via Canaletto, 24 /41042 Fiorano Modenese (MO) / T. +39 0536 840111 / F. +39 0536 844750 / florim.com